

SECTION D-D
(4809-1T ONLY)

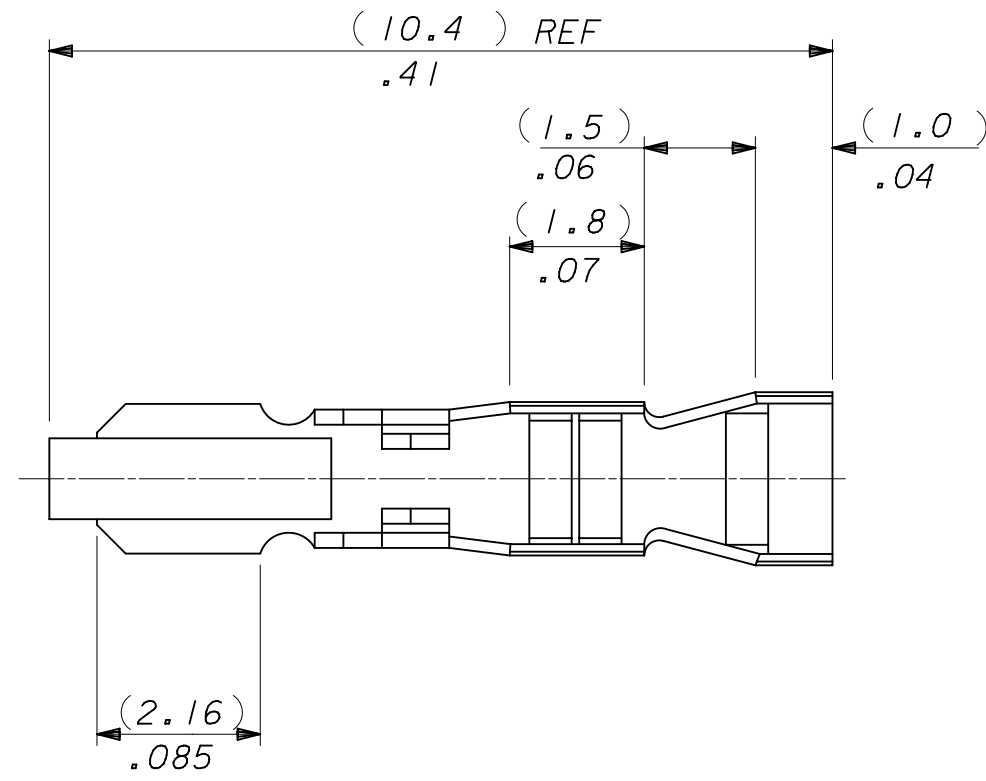

NOTES:

1. MATERIAL: (0.21)/.008 THICK BRASS.
2. FINISH: SEE SHEET 2.
3. THIS PART CONFORMS TO PRODUCT SPEC. 99020-0088.
4. TERMINAL MUST MEET BEND SPEC. SDES-219.
5. SUITABLE FOR 22-30 GA. WIRE, (1.57)/.062 MAX. INSULATION.
6. THIS PART CONFORMS TO CLASS B REQUIREMENTS OF COSMETIC SPECIFICATION PS-45499-002.

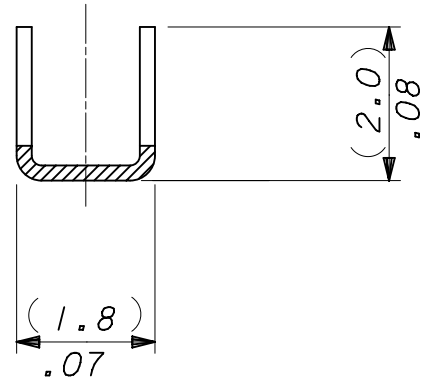
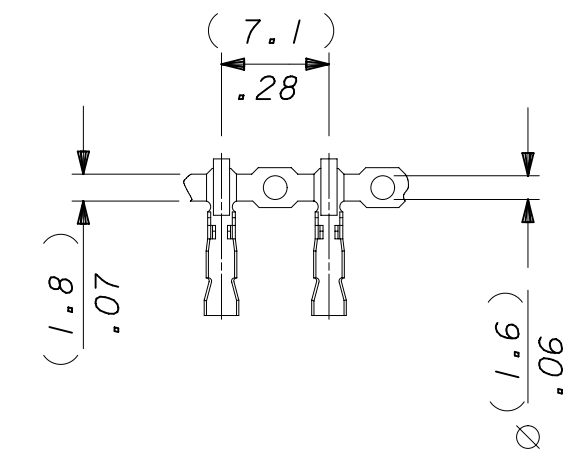
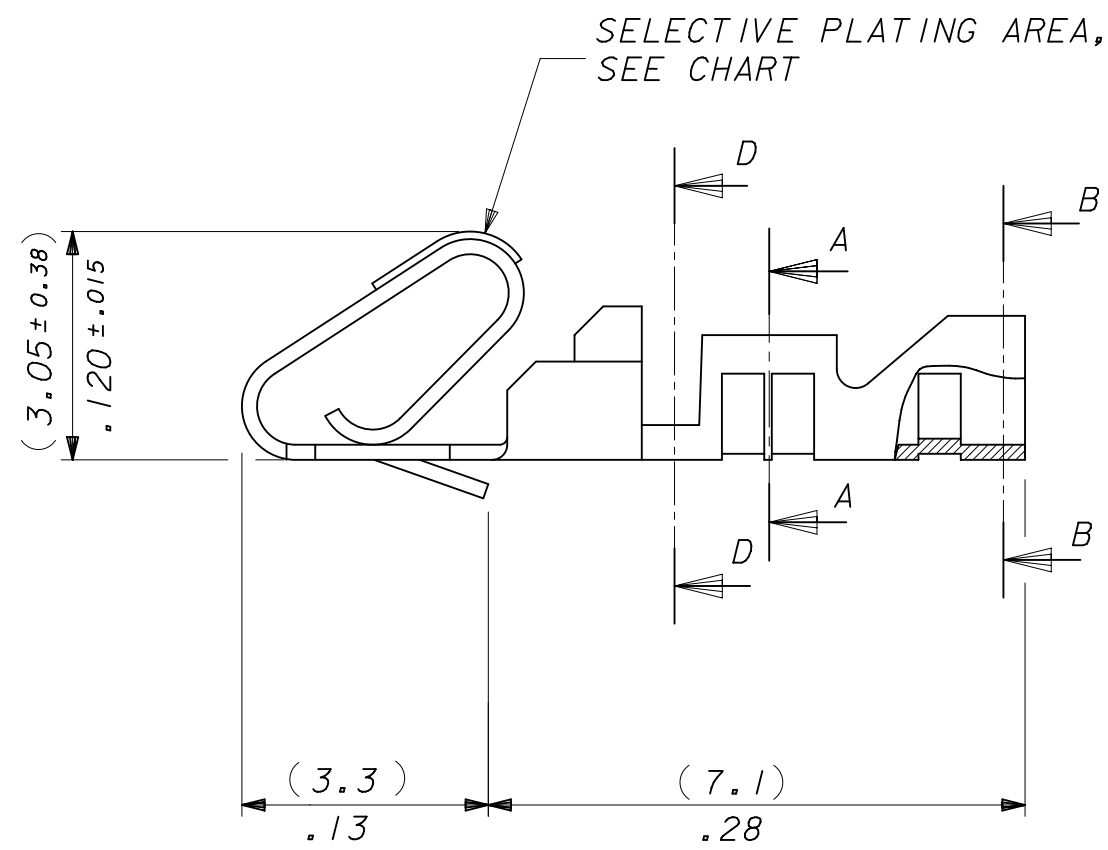
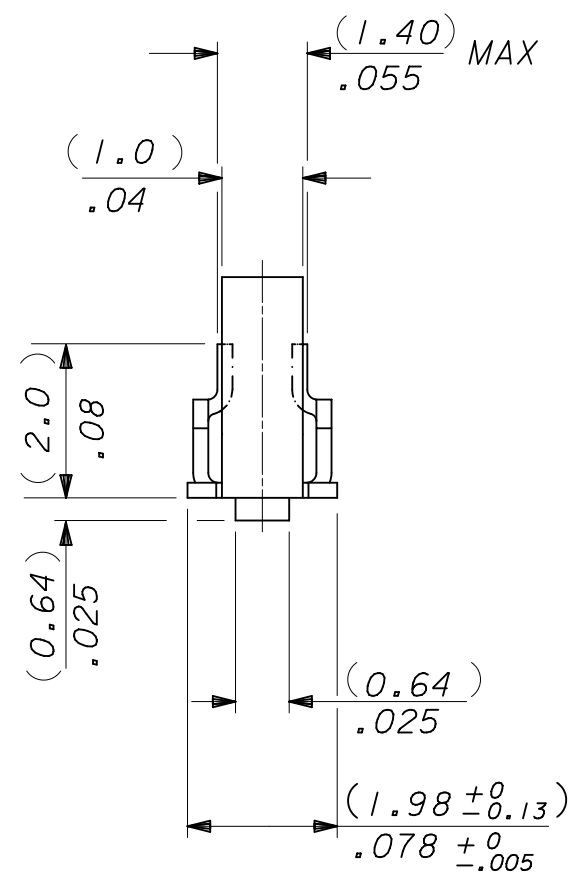

CARRIER STRIP DETAIL
SCALE 2:1

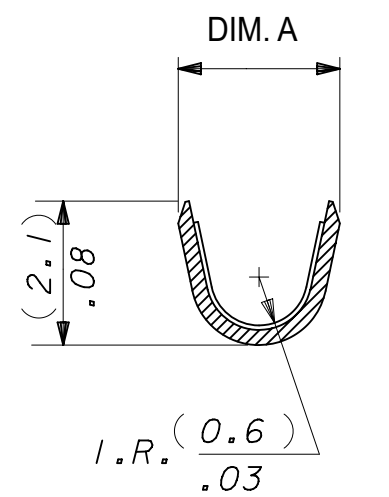

SECTION B-B

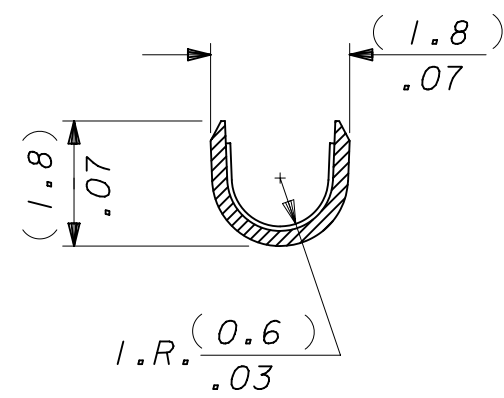

SECTION A-A

4809-(*)**

- BLANK : DIM. A = (2.1) / 1.083 REF.
- M: DIM A = (2.2) / .087 REF.
- BLANK=CHAIN FORM TOP FEEDING REEL
- L=LOOSE FORM

PLATING CODE

THIS DRAWING CONTAINS INFORMATION THAT IS PROPRIETARY TO MOLEX ELECTRONIC TECHNOLOGIES, LLC AND SHOULD NOT BE USED WITHOUT WRITTEN PERMISSION									
DIMENSION UNITS		SCALE		CURRENT REV DESC: OBSOLETE PART NUMBERS AS PER PCN#509450.				molex	
MM/IN		10:1							
GENERAL TOLERANCES (UNLESS SPECIFIED)				EC NO: 694111				ANTI-FISH HOOKING TERMINAL KK,(2.50)/.100	
				DRWN: SANTHN 2022/01/28					
4 PLACES ±				CHK'D: GGA 2022/03/31				PRODUCT CUSTOMER DRAWING	
3 PLACES ±				APPR: GGA 2022/03/31					
2 PLACES ± 0.25 ± 0.014				INITIAL REVISION:				DOCUMENT NUMBER	
1 PLACE ± 0.35 ±				DRWN: MCC 1986/07/30					
0 PLACES ±				APPR: JDENNEHY 2004/10/19				SD-4809-X	
ANGULAR TOL ± °				THIRD ANGLE PROJECTION		DRAWING		SERIES	
DRAFT WHERE APPLICABLE MUST REMAIN WITHIN DIMENSIONS				C-SIZE		4809		MATERIAL NUMBER	
				SEE CHART		CUSTOMER		SHEET NUMBER	
				GENERAL MARKET		1 OF 2			

FINISH NOTES:

(550) GOLD PLATE (0.00038)/.000015 MIN. OVER (0.00076)/.000030 MIN. NICKEL

IN CONTACT AREA WITH (0.00005)/.000002 MIN. GOLD FLASH OVERALL.

(555) SELECTIVE GOLD (0.00038)/.000015 MIN. OVER (0.00076)/.000030 MIN. NICKEL IN CONTACT AREA ONL

(P918) HOT TIN DIP (0.00102-0.00305)/.000040-.000120

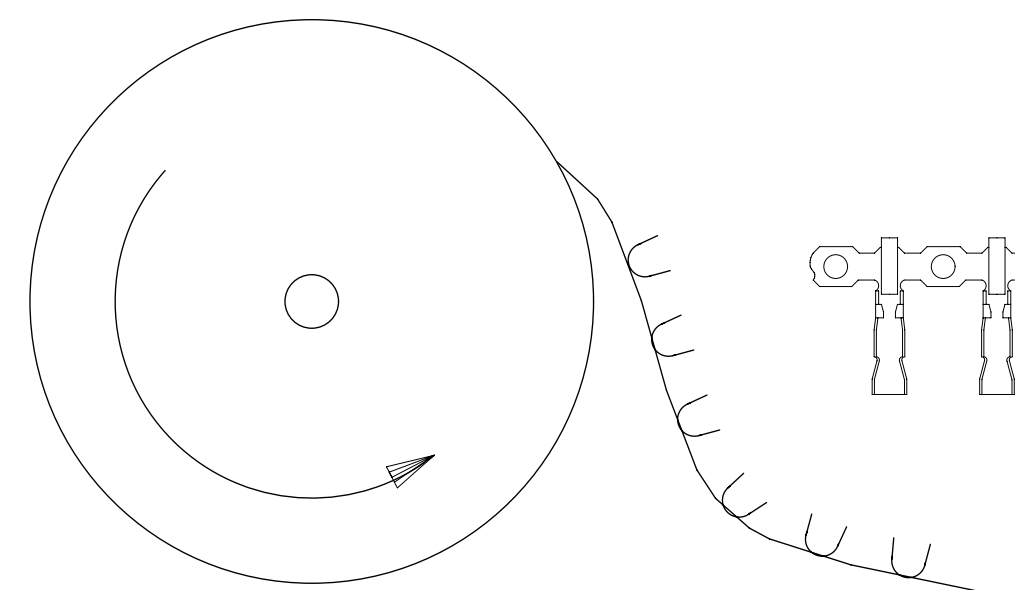

TERMINALS FEEDING FROM THE TOP OF THE REEL ARE STANDARD WOUND

08 - 55 - 0110	4809 - (555)	CHAIN	(555)	(2.45 - 1.75)/ .096 - .069
08 - 56 - 0120	4809 - (550)	CHAIN	(550)	(2.45 - 1.75)/ .096 - .069
08 - 50 - 0135	4809 - (P918)	CHAIN	(P918)	(2.45 - 1.75)/ .096 - .069
PART No	ENG No	FORM	FINISH	DIM . A
TOP FEEDING REELS ONLY				

THIS DRAWING CONTAINS INFORMATION THAT IS PROPRIETARY TO MOLEX ELECTRONIC TECHNOLOGIES, LLC AND SHOULD NOT BE USED WITHOUT WRITTEN PERMISSION											
DIMENSION UNITS MM/IN		SCALE 1:1		CURRENT REV DESC: OBSOLETE PART NUMBERS AS PER PCN#509450.			molex				
GENERAL TOLERANCES (UNLESS SPECIFIED)				EC NO: 694111							
		MM	INCH	DRWN: SANTHN 2022/01/28			ANTI-FISH HOOKING TERMINAL KK,(2.50)/.100				
4 PLACES		±	±	CHK'D: GGA 2022/03/31							
3 PLACES		±	± 0.01	APPR: GGA 2022/03/31			PRODUCT CUSTOMER DRAWING				
2 PLACES		± 0.25	± 0.014	INITIAL REVISION:							
1 PLACE		± 0.35	±	DRWN: MCC 1986/07/30			DOCUMENT NUMBER		DOC TYPE	DOC PART	REVISION
0 PLACES		±	±	APPR: JDENNEHY 2004/10/19			SD-4809-X		PSD	001	AP
ANGULAR TOL		±	°	THIRD ANGLE PROJECTION		DRAWING	SERIES	MATERIAL NUMBER	CUSTOMER	SHEET NUMBER	
DRAFT WHERE APPLICABLE MUST REMAIN WITHIN DIMENSIONS						C-SIZE	4809	SEE CHART	GENERAL MARKET	2 OF 2	

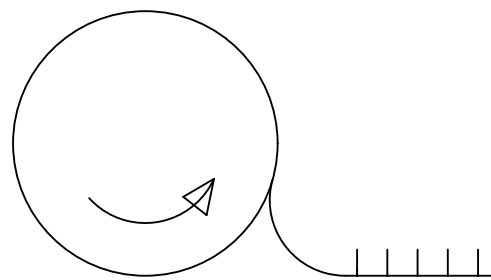

'B' WINDING REEL
PER ES 339

4809C - (*) * *

INSULATION CRIMP WIDTH
BLANK: DIM. A = (2.1)/.083 REF.
M: DIM. A = (2.2)/.087 REF.

PLATING CODE

FORM:

BLANK = CHAIN FORM. TOP FEEDING REEL
L = LOOSE FORM
BF = CHAIN FORM, BOTTOM FEEDING REEL

SELECTIVE GOLD
LOCATION

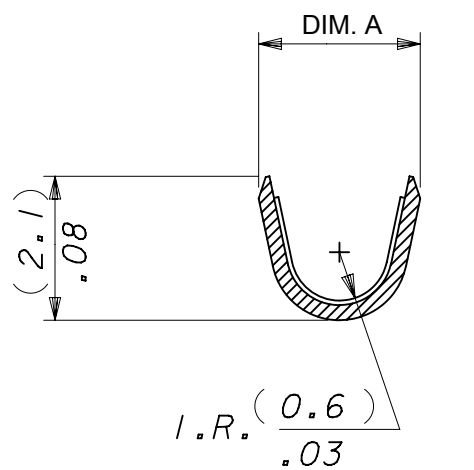
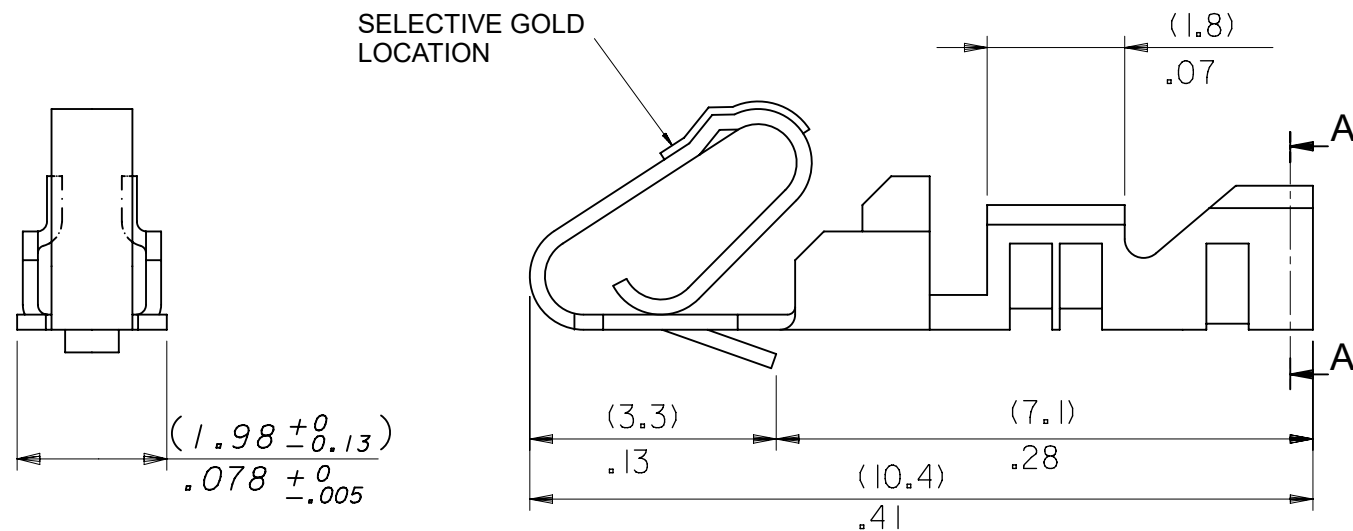

SECTION A-A

08-55-0112	4809C-(555)	CHAIN	(555)	(2.45-1.75)/ .096-.069
08-50-0030	4809C-(P918)M	CHAIN	(P918)	(2.35-2.05)/ .093-.081
08-50-0031	4809C-(P918)	CHAIN	(P918)	(2.45-1.75)/ .096-.069
08-50-0032	4809C-(P918)L	LOOSE	(P918)	(2.45-1.75)/ .096-.069
PART No	ENG No	FORM	FINISH (SEE NOTE-2)	DIM . A
'B' WINDING PER E.S.339 (CHAIN ONLY)				

NOTES:

1. MATERIAL (0.20±0.01)/.008±.0004 THICK BRASS.
2. FINISH: (555) - SELECTIVE GOLD (0.00038)/0.000015 MIN., OVERALL NICKEL (0.00076)/0.000030 MIN.
(P918) - HOT TIN DIP: (0.00102-0.00305)/.000040-.000120
3. THIS PART CONFORMS TO MOLEX PRODUCT SPEC. PS-99020-0088.
4. SAME AS SD-4809-* EXCEPT WITH CAT EARS.
5. FOR 22-30 GAUGE WIRE & (1.57)/.062 DIA. INSULATION MAX.
6. THIS PART CONFORMS TO CLASS B REQUIREMENTS OF COSMETIC SPECIFICATION PS-45499-002.

PRE-RELEASE
REFERENCE
USE ONLY

THIS DRAWING CONTAINS INFORMATION THAT IS PROPRIETARY TO MOLEX ELECTRONIC TECHNOLOGIES, LLC AND SHOULD NOT BE USED WITHOUT WRITTEN PERMISSION									
DIMENSION UNITS MM/IN		SCALE NTS		CURRENT REV DESC: REMOVED OBSOLETE PART NUMBER AS PER PCN#509450.				molex	
GENERAL TOLERANCES (UNLESS SPECIFIED)				EC NO: 694111					
				DRWN: SANTHN 2022/01/31				ANTI FISH HOOKING TERMINAL KK,(2.50)/.100 WITH CAT EARS	
				CHK'D: GGA 2022/03/31					
				APPR: GGA 2022/03/31				PRODUCT CUSTOMER DRAWING	
				INITIAL REVISION:					
				DRWN: AOD 1999/02/20				DOCUMENT NUMBER SD-4809C-XXXX	
				APPR: JDENNEHY 2004/10/19					
				THIRD ANGLE PROJECTION				DOC TYPE DOC PART REVISION PSD 001 N	
				DRAWING					
				SERIES				MATERIAL NUMBER CUSTOMER SHEET NUMBER SEE CHART GENERAL MARKET 1 OF 1	
				B-SIZE 4809					