

# HDAS-524, HDAS-528

## 12-Bit, 400kHz, Complete Data Acquisition Systems



### FEATURES

- 12-Bit resolution, 400kHz throughput
- 8 Channels single-ended or 4 channels differential
- Miniature, 40-pin, ceramic DDIP
- Full scale input range from 100mV to 10V
- Three-state outputs
- No missing codes

### GENERAL DESCRIPTION

The HDAS-524 and HDAS-528 are complete data acquisition systems. Each contains an internal multiplexer, instrumentation amplifier, sample-hold, analog-to-digital converter and three-state outputs. Packaged in miniature, 40-pin, double-dip packages, the HDAS-524/528 have a low power dissipation of 2.6 Watts.

The HDAS-524 provides 4 differential inputs, and the HDAS-528 provides 8 single-ended inputs. An internal instrumentation amplifier is characterized for gains of 1, 2, 4, 8, 10 and 100. The gain range is selectable through a single external resistor.

### HDAS-524/528 OPERATION

The HDAS devices accept either 8 single-ended or 4 differential input signals. Tie unused channels to SIGNAL GROUND, pin 14. Channel selection is accomplished using the multiplexer address pins as shown in Table 1. Obtain additional channels by connecting external multiplexers.

The acquisition time is the amount of time the multiplexer, instrumentation amplifier and sample-hold require to settle within a specified range of accuracy. The acquisition time can be measured by how long EOC is low before the rising edge

*Continued on page 8-12*



### INPUT/OUTPUT CONNECTIONS

PIN	FUNCTION	PIN	FUNCTION
1	CH0/CH0 HI	40	START CONVERT
2	CH1/CH1 HI	39	CA2
3	CH2/CH2 HI	38	CA1
4	CH3/CH3 HI	37	CA0
5	CH7/CH3 LO	36	+5V SUPPLY
6	CH6/CH2 LO	35	DIGITAL GROUND
7	CH5/CH1 LO	34	ENABLE
8	CH4/CH0 LO	33	BIT 1 (MSB)
9	COMP BIN	32	BIT 2
10	RGAIN LO	31	BIT 3
11	RGAIN HI	30	BIT 4
12	S/H OUT	29	BIT 5
13	+10V REFERENCE OUT	28	BIT 6
14	SIGNAL GROUND	27	BIT 7
15	GAIN ADJUST	26	BIT 8
16	OFFSET ADJUST	25	BIT 9
17	BIPOLAR	24	BIT 10
18	-15V SUPPLY	23	BIT 11
19	ANALOG GROUND	22	BIT 12 (LSB)
20	+15V SUPPLY	21	EOC

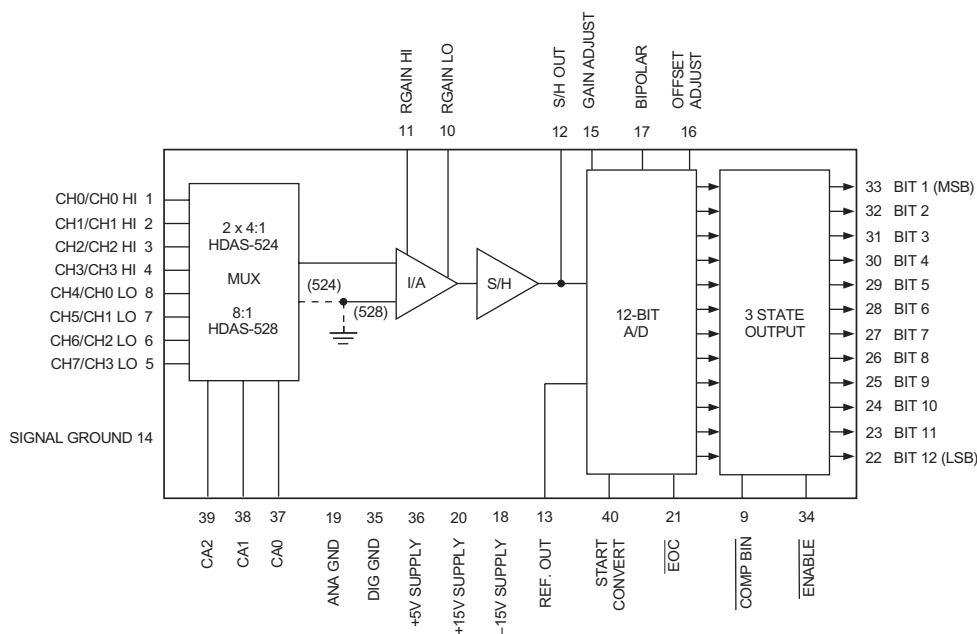

Figure 1. Functional Block Diagram

**ABSOLUTE MAXIMUM RATINGS**

PARAMETERS	MIN.	TYP.	MAX.	UNITS
+15V Supply, Pin 20	0	—	+18	Volts
-15V Supply, Pin 18	0	—	-18	Volts
+5V Supply, Pin 36	-0.5	—	+7	Volts
Digital Inputs, Pins 9, 34, 37-40	-0.3	—	+V <sub>DD</sub> +0.3	Volts
Analog Inputs, Pins 1-8	-15	—	+15	Volts
Lead Temperature (10 seconds)	—	—	300	°C

**FUNCTIONAL SPECIFICATIONS**

(Apply over the operating temperature range with ±15V and +5V supplies unless otherwise specified.)

ANALOG INPUTS	MIN.	TYP.	MAX.	UNITS
<b>Number of Inputs</b> HDAS-524 HDAS-528	4 differential inputs 8 single-ended inputs			
<b>Input Voltage Ranges</b> Gain = 1 Gain = 100	0 to +10V, ±10V 0 to +100mV, ±100mV			
<b>I.A. Gain Ranges</b>	1, 2, 4, 8, 10, 100			
<b>Input Impedance</b> CH On, CH Off	10 <sup>11</sup>	10 <sup>12</sup>	—	Ohms
<b>Input Capacitance</b> (-524) CH On, CH Off (-528) CH On, CH Off	—	—	12 25	pF
<b>Input Bias Current</b>	—	—	±200	pA
<b>Input Offset Current</b>	—	—	±50	pA
<b>Input Offset Voltage</b>	—	—	±10	mV
<b>Common Mode Voltage Range</b>	±11	—	—	Volts
<b>CMRR, G = 1, @10Hz,</b> V <sub>cm</sub> = 1Vp-p	72	80	—	dB
<b>Voltage Noise (RMS)</b> Gain = 1 Gain = 8	—	—	200 50	μV
<b>MUX Crosstalk @125kHz</b>	-72	—	—	dB
<b>MUX ON Resistance</b>	—	450	500	Ohms
<b>Bias Current Tempco</b>	Doubles (max.) every 10°C above +70°C			
<b>Offset Current Tempco</b>	Doubles (max.) every 10°C above +70°C			
<b>Offset Voltage Tempco</b>	(±30ppm/°C x gain) ±20ppm/°C (max.)			
<b>Input Gain Equation</b>	$GAIN = \frac{2k\Omega}{R_{GAIN}} + 1$			
DIGITAL INPUTS				
<b>Logic Levels</b> Logic 1 Logic 0	+2.0	—	— +0.5	Volts
<b>Logic Loading</b> Logic 1 Logic 0	—	—	+5 -600	μA
OUTPUTS				
<b>Logic Levels</b> Logic 1 Logic 0	+2.4	—	— +0.4	Volts
<b>Logic Loading</b> Logic 1 Logic 0	—	—	-160 +6.4	μA
<b>Internal Reference</b> Voltage, +25°C Drift External Current	+9.9	+10.0	+10.1	Volts
	—	±5	±35	ppm/°C
	—	—	1.5	mA
<b>Output Coding</b>	Straight binary/Offset binary Comp. binary/Comp. offset binary			

**Footnotes:**

① Specifications valid at +25°C and over the temperature ranges of 0 to +70°C or -55 to +125°C.

PERFORMANCE	MIN.	TYP.	MAX.	UNITS
<b>Resolution</b>	12	—	—	Bits
<b>Integral Nonlinearity, +25°C</b> 0 to +70°C	—	—	±0.75	LSB
-55 to +125°C	—	—	±0.75	LSB
<b>Differential Nonlinearity, +25°C</b> 0 to +70°C	—	—	±1.5	LSB
-55 to +125°C	—	—	±0.75	LSB
<b>F.S. Abs. Accuracy, +25°C</b> 0 to +70°C	—	±0.13	±0.3	%FSR
-55 to +125°C	—	±0.15	±0.5	%FSR
<b>Unipolar Zero Error, +25°C</b>	—	±0.25	±0.78	%FSR
<b>Unipolar Zero Tempco</b>	—	±0.074	±0.15	%FSR
<b>Bipolar Zero Error, +25°C</b>	—	±15	±30	ppm/°C
<b>Bipolar Zero Tempco</b>	—	±0.074	±0.15	%FSR
<b>Bipolar Offset Error, +25°C</b>	—	±5	±10	ppm/°C
<b>Bipolar Offset Tempco</b>	—	±0.1	±0.25	%FSR
<b>Gain Error, +25°C</b>	—	±20	±40	ppm/°C
<b>Gain Tempco</b>	—	±0.1	±0.25	%
<b>Harmonic Distortion (-FS)</b> (DC to 5kHz, 10Vp-p) ①	—	-73	-65	dB
<b>No Missing Codes</b>	Over operating temperature range			
SIGNAL TIMING				
<b>Enable to Data Valid Delay</b>	—	—	10	ns
<b>MUX Address Set-up Time</b>	400	—	—	ns
<b>Start Convert Pulse Width</b>	50	100	—	ns
<b>Data Valid After</b> EOC Signal Goes Low	—	—	20	ns
<b>Conversion Time, +25°C</b> 0 to +70°C	—	—	800	ns
-55 to +125°C	—	—	850	ns
<b>Throughput Rates</b> ①	—	—	880	ns
Gain = 1	400	—	—	kHz
Gain = 2	325	—	—	kHz
Gain = 4	275	—	—	kHz
Gain = 8	225	—	—	kHz
Gain = 10	175	—	—	kHz
Gain = 100	40	—	—	kHz
S/H PERFORMANCE				
<b>Acquisition Time</b> Full-Scale Step to ±0.01%	—	500	900	ns
Full-Scale Step to ±0.1%	—	400	750	ns
<b>Aperture Delay</b>	-50	-20	0	ns
<b>Aperture Uncertainty</b>	—	—	±150	ps
<b>Slew Rate</b>	±70	±90	—	V/μs
<b>Hold Mode Settling Time</b> To ±1mV	—	100	200	ns
To ±10mV	—	75	150	ns
<b>Feedthrough Rejection</b>	80	88	—	dB
<b>Droop Rate</b> ①	—	±0.1	±100	μV/μs
POWER SUPPLIES				
<b>Range, +15V Supply</b>	+14.25	+15.0	+15.75	Volts
-15V Supply	-14.25	-15.0	-15.75	Volts
+5V Supply	+4.75	+5.0	+5.25	Volts
<b>Current, +15V Supply</b>	—	+78	+90	mA
-15V Supply	—	-72	-82	mA
+5V Supply	—	+75	+95	mA
<b>Power Dissipation</b>	—	2.6	3	Watts
<b>Power Supply Rejection</b>	—	—	±0.05	%FSR/%V
PHYSICAL/ENVIRONMENTAL				
<b>Oper. Temp. Range, Case, -MC,</b> -MM, 883	0	—	+70	°C
<b>Storage Temp. Range</b>	-55	—	+125	°C
<b>Package Type</b>	-65	—	+150	°C
<b>Weight</b>	40-pin ceramic DDIP 0.56 ounces (16 grams)			

**HDAS-524/528 OPERATION (Continued)**

of the START CONVERT pulse for continuous operation. Higher gains require the use of the R<sub>GAIN</sub> resistor to increase the acquisition time. The gain is equal to 1 without an R<sub>GAIN</sub> resistor. Table 2 refers to the appropriate R<sub>GAIN</sub> resistors for various throughputs.

The HDAS devices enter the hold mode and are ready for conversion upon the start convert going high. The conversion is complete within a maximum of 800ns (+25°C).  $\overline{EOC}$  returns low, the data is valid and sent to the three-state output buffers. The sample/hold is now ready to acquire new data.

**Table 1. MUX Channel Addressing**

MUX ADDRESS PINS			CHANNEL
39 CA2	38 CA1	37 CA0	
0	0	0	0
0	0	1	1
0	1	0	2
0	1	1	3
1	0	0	4
1	0	1	5
1	1	0	6
1	1	1	7

**Table 2. Input Range Parameters**

INPUT RANGE	GAIN	R <sub>GAIN</sub>	THROUGHPUT
0 to +10V	1	OPEN	400kHz
0 to +5V	2	2kΩ	325kHz
0 to +2.5V	4	665Ω	275kHz
0 to +1.25V	8	287Ω	225kHz
0 to +1V	10	221Ω	175kHz
0 to +100mV	100	20Ω	40kHz
±10V	1	OPEN	400kHz
±5V	2	2kΩ	325kHz
±2.5V	4	665Ω	275kHz
±1.25V	8	287Ω	225kHz
±1V	10	221Ω	175kHz
±100mV	100	20Ω	40kHz

$$R_{GAIN} = \frac{2k\Omega}{(GAIN - 1)} \quad GAIN = \frac{2k\Omega}{R_{GAIN}} + 1$$

**Table 3. Zero and Gain Adjust**

INPUT RANGE	ZERO ADJUST +1/2LSB	GAIN ADJUST +FS - 1 1/2LSB
0 to +10V	+1.22mV	+9.9963V
±10V	+2.44mV	+9.9927V

**CALIBRATION PROCEDURE**

1. Connect the converter per Figure 2 and Tables 2 and 3 for the appropriate input range. Apply a pulse of 100 nano-seconds (typical) to the START CONVERT input (pin 40) at a rate of 100kHz. This rate is chosen to reduce flicker if LED's are used on the outputs for calibration purposes.

**2. Zero Adjustments**

Apply a precision voltage reference source between the analog input and SIGNAL GROUND (pin 14). Adjust the output of the reference source per Table 3. For unipolar, adjust the zero trimming potentiometer so that the output code flickers equally between 0000 0000 0000 and 0000 0000 0001 with the COMP BIN (pin 9) tied high (straight binary) or between 1111 1111 1111 and 1111 1111 1110 with the  $\overline{COMP BIN}$  (pin 9) tied low (complementary binary).

For bipolar operation, adjust the potentiometer such that the code flickers equally between 1000 0000 0000 and 1000 0000 0001 with COMP BIN (pin 9) tied high (offset binary) or between 0111 1111 1111 and 0111 1111 1110 with COMP BIN (pin 9) tied low (complementary offset binary).

**3. Full-Scale Adjustment**

Set the output of the voltage reference used in step 2 to the value shown in Table 3. Adjust the gain trimming potentiometer so that the output code flickers equally between 1111 1111 1110 and 1111 1111 1111 or 0000 0000 0001 and 0000 0000 0000 for complementary coding.

4. To confirm proper operation of the device, vary the precision reference voltage source to obtain the output coding listed in Table 4.

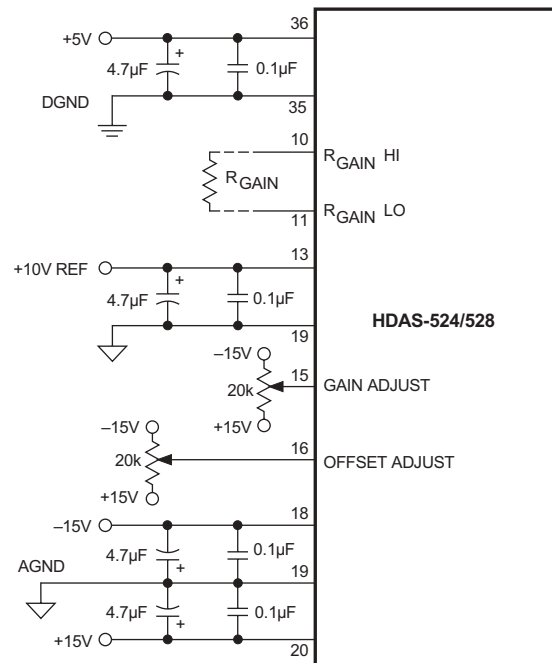

**Figure 2. Typical Connection Diagram**

**Notes:**

1. For unipolar operation, connect pin 12 to pin 17.
2. For bipolar operation, connect pin 13 to pin 17.
3. Position R<sub>GAIN</sub> as close as possible to pins 10 and 11. Use RN55C, 1% resistors.
4. If gain and offset adjusts are not used, connect pin 15 to ground and leave pin 16 open.

**TECHNICAL NOTES**

1. Rated performance requires using good high-frequency circuit board layout techniques. The analog and digital ground pins are not connected to each other internally. Avoid ground-related problems by connecting the analog, signal and digital grounds to one point, the ground plane beneath the converter. Due to the inductance and resistance of the power supply return paths, return the analog and digital grounds separately to the power supplies. This prevents contamination of the analog ground by noisy digital ground currents.
2. Double-level multiplexing allows expanding the multiplexer channel capacity of the HDAS-528 from 8 single-ended channels to 128 single-ended channels or the HDAS-524 from 4 differential channels to 32 differential channels.
3. Obtain straight binary/offset binary output coding by tying COMP BIN (pin 9) to +5V or leaving it open. The device has an internal pull-up resistor on this pin. To obtain complementary binary or complementary offset binary output coding, tie pin 9 to ground. The COMP BIN signal is compatible to CMOS/TTL logic levels for those users desiring logic control of this function.
4. To enable the three-state outputs, connect  $\overline{\text{ENABLE}}$  (pin 34) to a logic "0" (low). To disable, connect pin 34 to a logic "1" (high).

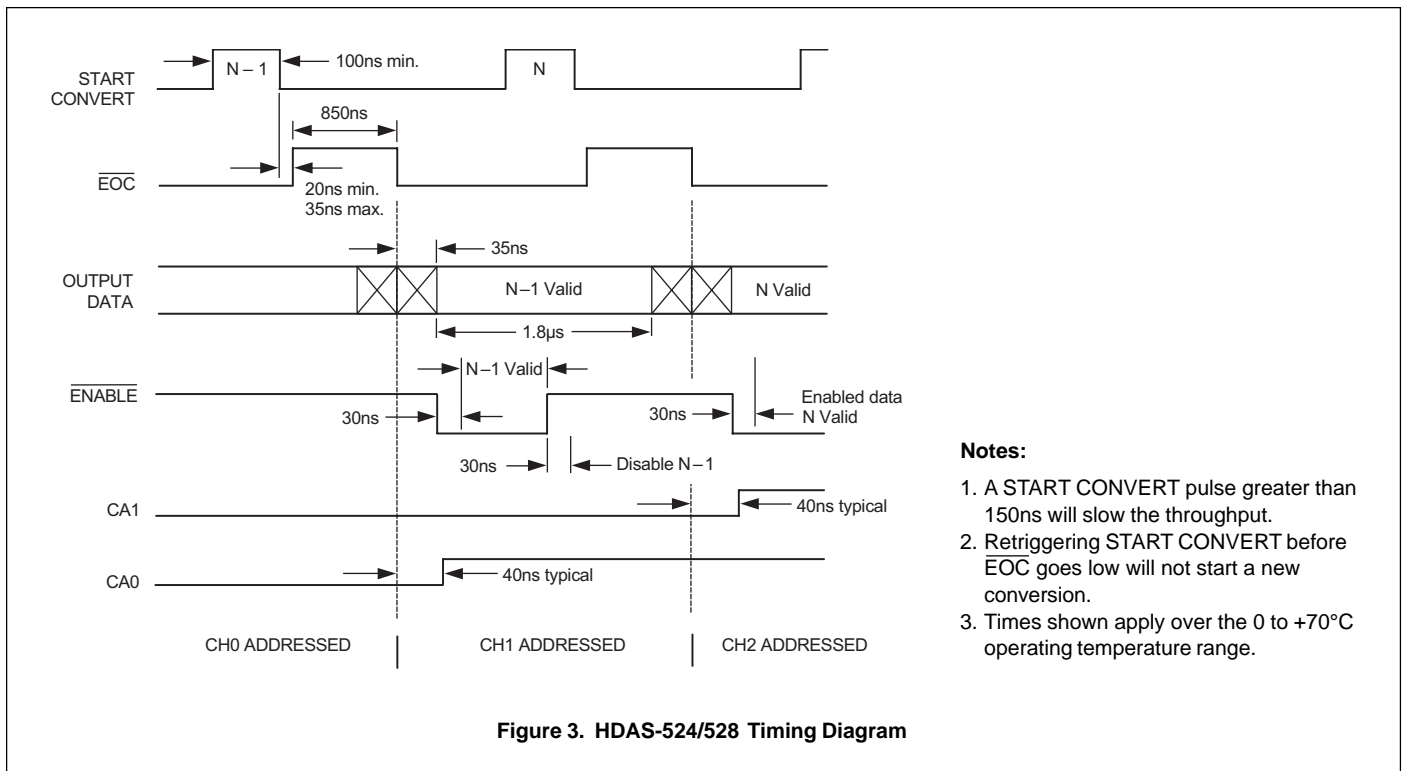

**Table 4. Output Coding**

UNIPOLAR SCALE	INPUT RANGE 0 to +10V	STRAIGHT BINARY			COMP. BINARY		INPUT RANGE ±10V	BIPOLAR SCALE
		MSB	OUTPUT CODING LSB		MSB	LSB		
+FS - 1LSB	+9.9976V	1111	1111	1111	0000	0000	0000	+FS - 1LSB
+7/8FS	+8.7500V	1110	0000	0000	0001	1111	1111	+3/4FS
+3/4FS	+7.5000V	1100	0000	0000	0011	1111	1111	+1/2FS
+1/2FS	+5.0000V	1000	0000	0000	0111	1111	1111	0
+1/4FS	+2.5000V	0100	0000	0000	1011	1111	1111	-1/2FS
+1/8FS	+1.2500V	0010	0000	0000	1101	1111	1111	-3/4FS
+1LSB	+0.0024V	0000	0000	0001	1111	1111	1110	-FS + 1LSB
0	0.0000V	0000	0000	0000	1111	1111	1111	-FS
		OFFSET BINARY			COMP. OFF. BINARY			

**MECHANICAL DIMENSIONS**  
INCHES (mm)

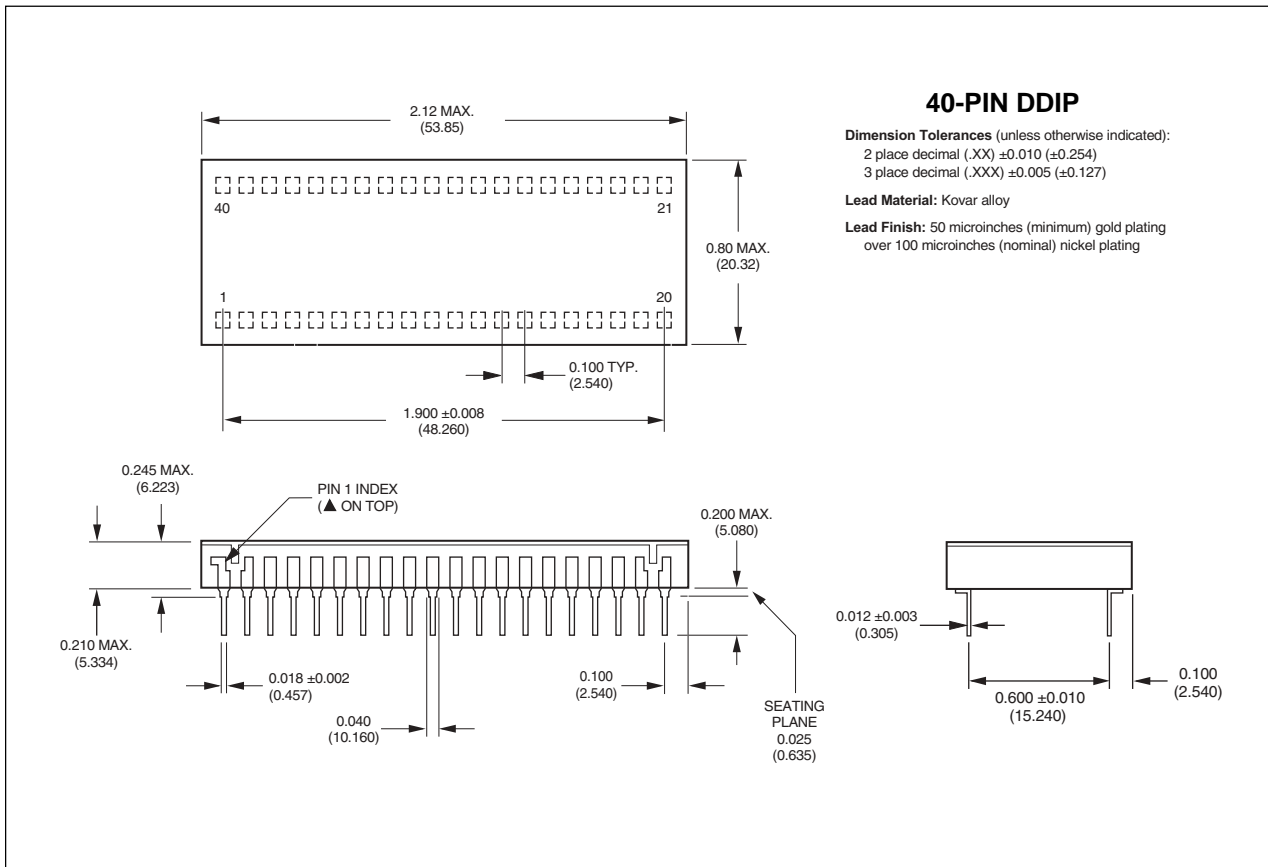

**ORDERING INFORMATION**

MODEL NO.	INPUT	OPERATING TEMP. RANGE
HDAS-524MC	4D Channels	0 to +70°C
HDAS-524MM	4D Channels	-55 to +125°C
HDAS-528MC	8SE Channels	0 to +70°C
HDAS-528MM	8SE Channels	-55 to +125°C
HDAS-528/883	8SE Channels	-55 to +125°C

Receptacle for PC board mounting can be ordered through AMP Inc., Part #3-331272-8 (Component Lead Socket), 40 required.

Contact DATEL, Inc. for MIL-STD-883 product specifications.