

## Preliminary data

Bipolar IC

Type	Ordering code	Package
SDA 2311	Q67000-A2314	DIP 8

The IC has been designed for application in TV receivers using frequency selection according to the frequency synthesis concept. It includes a switchable preamplifier and an ECL divider with a 1:64 dividing ratio and symmetrical ECL push-pull outputs with emitter followers. The frequency range extends up to 1 GHz.

## Features

- Switchable inputs
- Low power consumption
- Few external components

## Maximum ratings

Supply voltage  
 Input voltage (peak-to-peak)  
 Divider outputs  
 Band selection input  
 Max. power dissipation  
 Junction temperature  
 ( $T_A = 25^\circ\text{C}$ )  
 Storage temperature range  
 Thermal resistance  
 (system-air)

$V_S$	6	V
$V_1, V_2$	2.5	V
$I_5, I_6$	-10 to 10	mA
$V_4$	20	V
$P_3$	0.45	W
$T_j$	150	$^\circ\text{C}$
$T_{stg}$	-40 to 125	$^\circ\text{C}$
$R_{thSA}$	115	K/W

## Operating range

Supply voltage  
 Input frequency  
 Ambient temperature

$V_3$	4.7 to 5.5	V
$f_1, f_2$	80 to 1000	MHz
$T_A$	0 to 70	$^\circ\text{C}$

**Characteristics** $V_S = 5\text{ V}$ ;  $T_A = 25\text{ }^\circ\text{C}$ 

	Test circuit	min	typ	max	
Input level UHF					
$V_4 = \text{"High"}$ ( $\text{"Input sensitivity"}$ )					
80 to 100 MHz	2	-24		3	dBm
100 to 800 MHz	2	-27		3	dBm
800 to 950 MHz	2	-16		3	dBm
950 to 1000 MHz	2	-12		3	dBm
$T_A = 0\text{ to }55\text{ }^\circ\text{C}$					
800 to 950 MHz	2	-21		3	dBm
950 to 1000 MHz	2	-18		3	dBm
Input level VHF					
$V_4 = \text{"Low"}$					
80 to 100 MHz	3	-24		3	dBm
100 to 500 MHz	3	-27		3	dBm
Current consumption	$I_3$		50	70	mA
Output voltage swing (peak-to-peak) (Load see test circuit)	$V_{5,6}$	4	0.6		V
Band selection input					
H level	$V_4$	3		18	V
L level	$V_4$	-0.5		0.6	V
Band selection current	$I_4$			2	mA
$V_4 = 5\text{ V}$					
Band selection current	$-I_4$			1	mA
$V_4 = 0\text{ V}$					

**Circuit description**

The IC amplifier includes a UHF, VHF, and a reference input. The UHF or the VHF input will be disabled in accordance with the "H" or "L" level at the band selection input. The HF input signals have to be coupled in the capacitive mode. The reference input is disabled by a capacitor with low series inductance connected to ground.

The divider of the IC consists of several state-controlled master-slave flipflops which determine the 1:64 dividing ratio. The push-pull outputs of the divider are emitter follower outputs with integrated pull-up resistances (1.8 k $\Omega$  against ground). The typical "High" level of the outputs is  $V_S - 0.7$  V and the typical voltage swing is 1 V (peak-to-peak).

**Pin description**

Pin	Function
1	UHF input
2	VHF input
3	Supply voltage + $V_S$
4	Band selection input
5	Divider output
6	Divider output
7	GND
8	Reference input

S parameter S<sub>11</sub> (typical)  
 to determine input impedance  
 Reference resistance Z<sub>0</sub> = 75 Ω

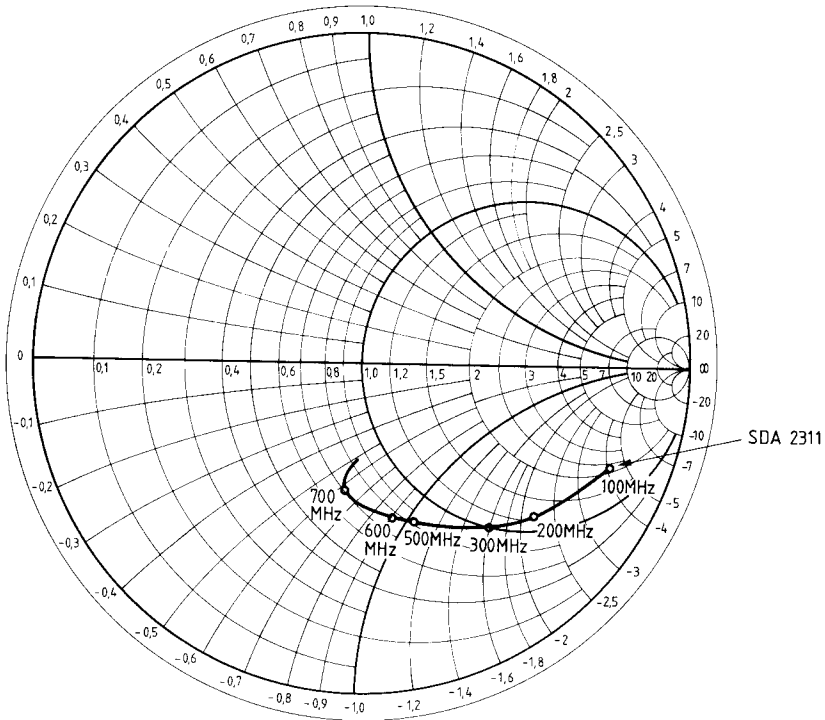

**Block diagram**

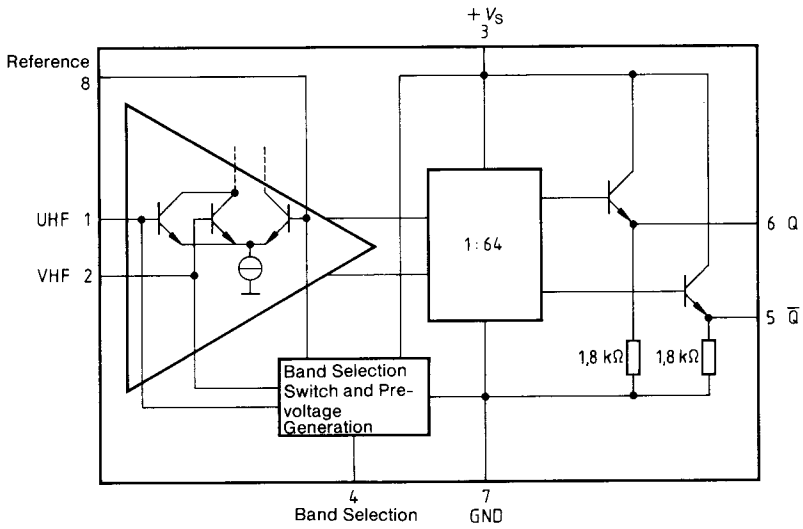

## Test and measurement circuits

### Signal generator

$Z_o = 50 \Omega$

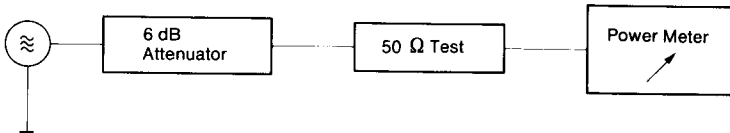

### Test circuit 1: Calibration of signal generator

#### Signal generator

$Z_o = 50 \Omega$

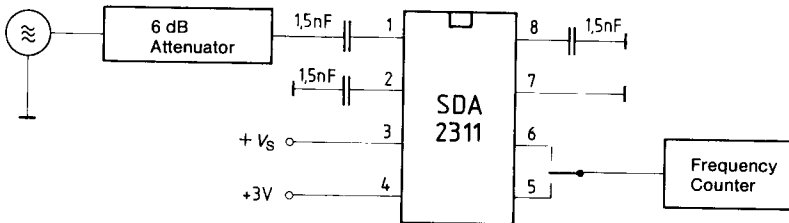

### Test circuit 2: Measurement of UHF input sensitivity

### Test and measurement circuits

#### Signal generator

$Z_o = 50 \Omega$

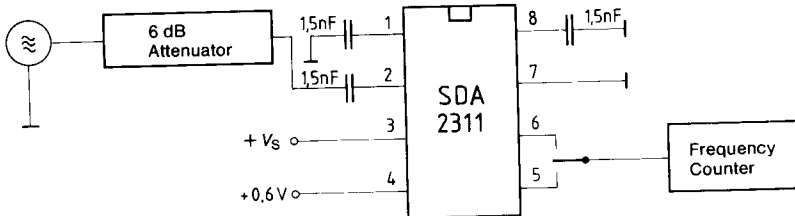

#### Test circuit 3: Measurement of VHF input sensitivity

#### Signal generator

$Z_o = 50 \Omega$

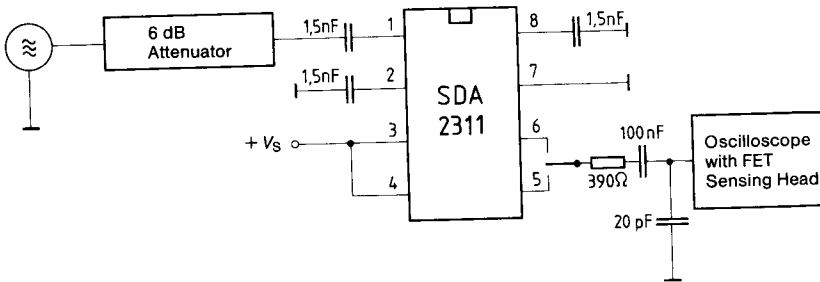

#### Test circuit 4: Measurement of output level