

Home Products Quick Quote My Parts List Site Map Contact Us



EPH11 Series Oscillator

Quartz Crystal Clock Oscillators XO (SPXO) HCMOS/TTL (CMOS) 5.0Vdc 8 Pin DIP Metal Thru-Hole



Revision B 03/25/2014

Electrical Specifications

Nominal Frequency	1.000MHz to 125.000MHz <i>Some frequencies within this range may not be available.</i>
Frequency Tolerance/Stability	(Inclusive of all conditions: Calibration Tolerance at 25°C, Frequency Stability over the Operating Temperature Range, Supply Voltage Change, Output Load Change, First Year Aging at 25°C, Shock, and Vibration) ±100ppm Maximum ±50ppm Maximum
Operating Temperature Range	-20°C to +70°C -40°C to +85°C
Supply Voltage (V_{DD})	5.0V _{DC} ±10%
Input Current	45mA Maximum (Unloaded)
Output Voltage Logic High (V_{OH})	I _{OH} = -16mA V _{DD} -0.4V _{DC} Minimum with HCMOS Load 2.4V _{DC} Minimum with TTL Load
Output Voltage Logic Low (V_{OL})	I _{OL} = +16mA 0.4V _{DC} Maximum
Duty Cycle	Measured at 1.4V _{DC} with TTL Load; Measured at 50% of waveform with HCMOS Load 50 ±10(%) 50 ±5(%) (Not available with TTL Load over Nominal Frequency range of 27.000001MHz to 125MHz; Not available with HCMOS Load over Nominal Frequency range of 50.000001MHz to 125MHz)
Rise Time/Fall Time	4nSec Maximum (Measured at 20% to 80% of waveform) with HCMOS Load 4nSec Maximum (Measured at 0.8V _{DC} to 2.0V _{DC}) with TTL Load
Load Drive Capability	50pF HCMOS Load Maximum over 1MHz to 50MHz 15pF HCMOS Load Maximum over 50.000001MHz to 125MHz 10TTL Load Maximum over 1MHz to 40MHz 5TTL Load Maximum over 40.000001MHz to 125MHz
Output Logic Type	CMOS TTL
Pin 1 Connection	Power Down (Disable Output: Logic Low) Tri-State (Disabled Output: High Impedance)
Pin 1 Input Voltage (V_{IH} and V_{IL})	+2.0V _{DC} Minimum to enable output, +0.8V _{DC} to disable output, No Connect to enable output.
Standby Current	50µA Maximum (Pin 1 = Ground)
Disable Current	30mA Maximum (Pin 1 = Ground)

Peak to Peak Jitter (tPK)	500pSec Maximum, 90pSec Typical over Nominal Frequency of 1MHz to 11.999999MHz 100pSec Maximum, 50pSec Typical over Nominal Frequency of 12MHz to 125MHz
RMS Period Jitter (tRMS)	50pSec Maximum, 13pSec Typical over Nominal Frequency of 1MHz to 11.999999MHz 13pSec Maximum, 8pSec Typical over Nominal Frequency of 12MHz to 125MHz
Start Up Time	10mSec Maximum
Aging (at 25°C)	±5ppm/year Maximum
Storage Temperature Range	-55°C to +125°C

Mechanical Dimensions

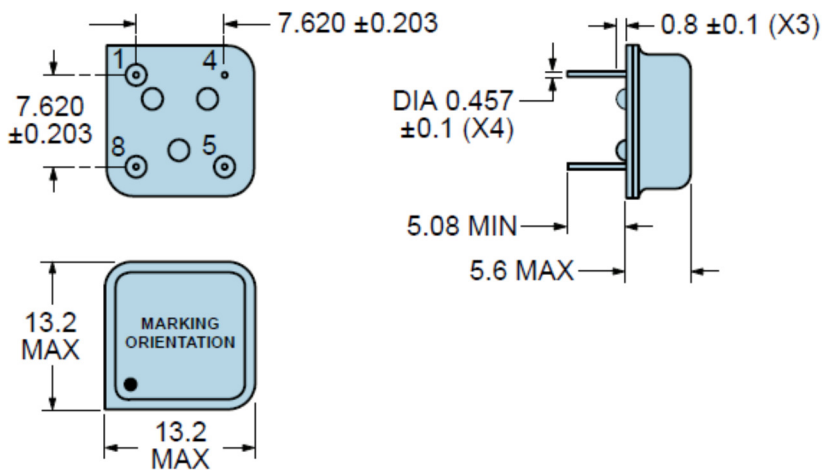

All Dimensions in Millimeters

Pin 1: Power Down (Logic Low) Or Tri-State (High Impedance)

Pin 5: Output

Pin 4: Ground/Case Ground

Pin 8: Supply Voltage

Marking Specifications

Line 1: **ECLIPTEK**

Line 2: **XXXXXXM**

- XXXXXX = Nominal Frequency (5 Digits + Decimal)
- M = Frequency unit of measure (MHz)

Line 3: **XXXXX**

- XXXXX = Ecliptek Manufacturing Identifier

Environmental and Mechanical Specifications

Fine Leak Test	MIL-STD-883, Method 1014, Condition A
Gross Leak Test	MIL-STD-883, Method 1014, Condition C
Lead Integrity	MIL-STD-883, Method 2004
Mechanical Shock	MIL-STD-202, Method 213, Condition C
Resistance to Soldering Heat	MIL-STD-202, Method 210
Resistance to Solvents	MIL-STD-202, Method 215
Solderability	MIL-STD-883, Method 2003
Temperature Cycling	MIL-STD-883, Method 1010
Vibration	MIL-STD-883, Method 2007, Condition A
Thermal Resistance (θ_{JA})	63°C/W (degrees Celsius per Watt)
Thermal Resistance (θ_{JC})	21°C/W (degrees Celsius per Watt)

EPH11 Value Added Options

Custom Lead Length Options for EPH11 Oscillators

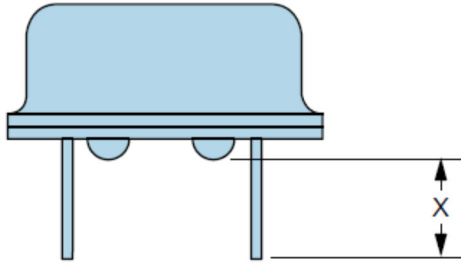

X DIMENSION		ECLIPTEK PART NUMBER SUFFIX
Millimeters	Inches	
2.540 ±0.500	0.100 ±0.020	CB
3.175 ±0.500	0.125 ±0.020	CC
3.810 ±0.500	0.150 ±0.020	CD
4.445 ±0.500	0.175 ±0.020	CE

Gull Wing Option G with Recommended Solder Pad Layout and Carrier Tape

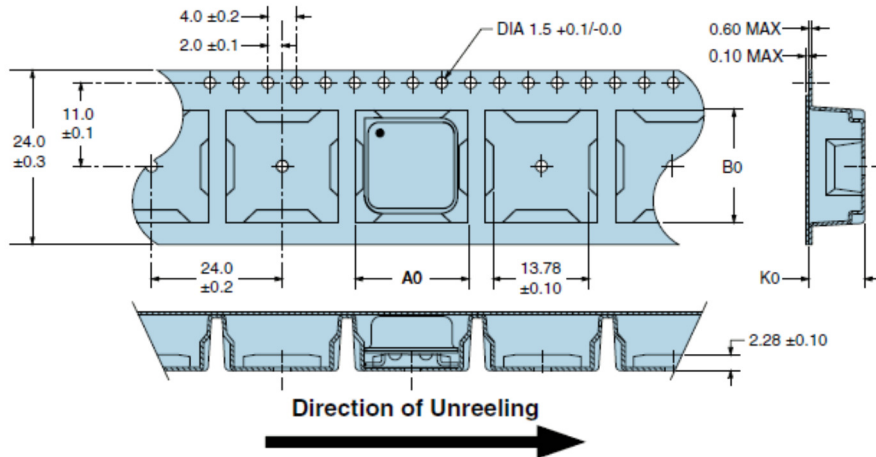
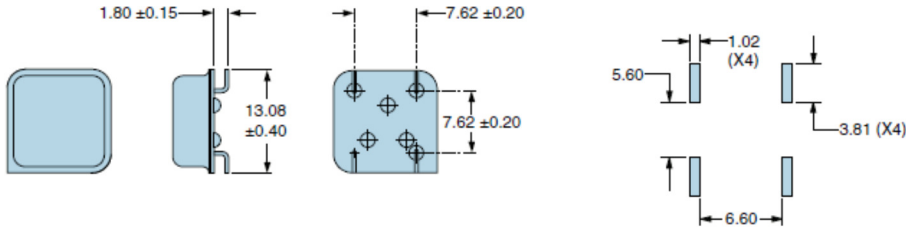

All Dimensions in Millimeters
Ecliptek Part Number Suffix: G

Gull Wing Option G2 with Recommended Solder Pad Layout and Carrier Tape

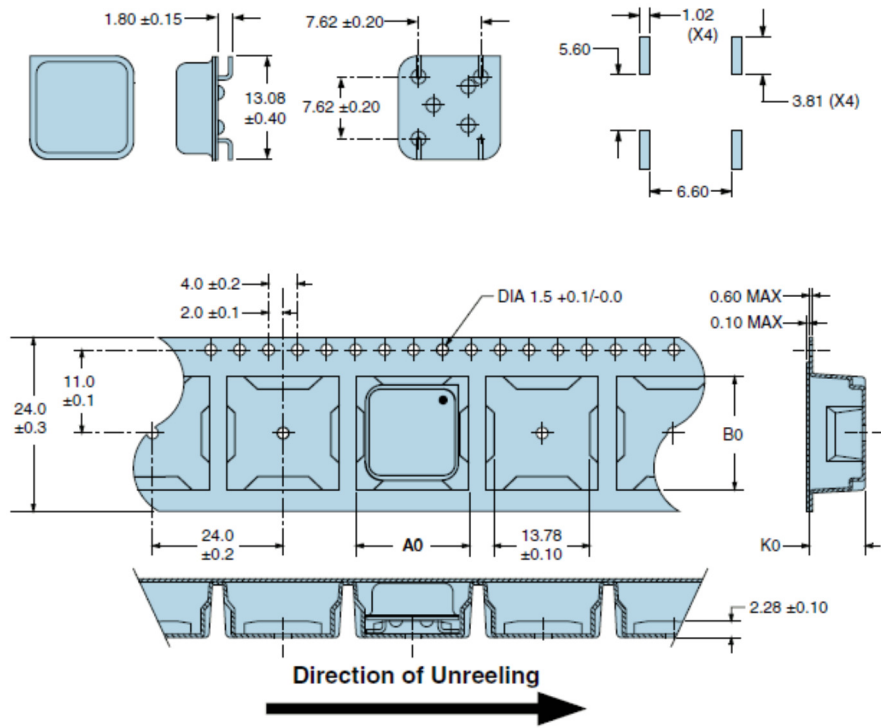

All Dimensions in Millimeters
Ecliptek Part Number Suffix: G2

Gull Wing Option G1 and G2 Reel Dimensions

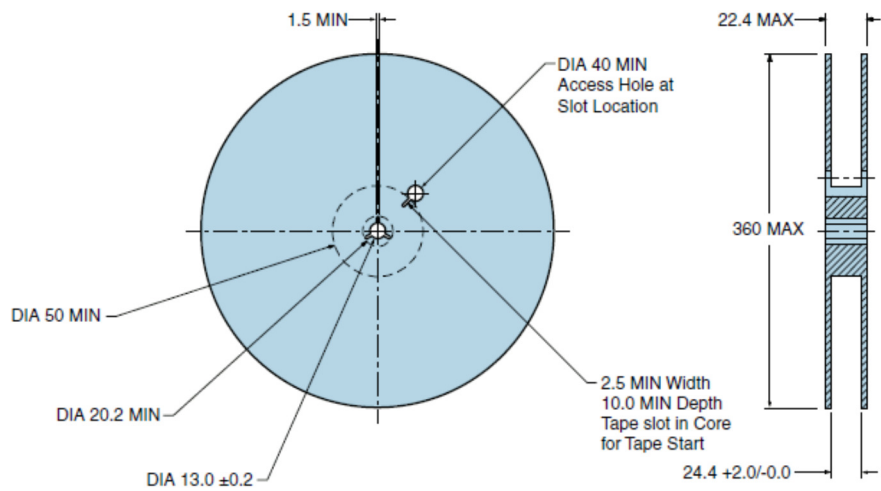

All Dimensions in Millimeters

TTL Test Circuit

Output Load Drive Capability	R_L Value (Ohms)	C_L Value (pF)
10TTL	390	15
5TTL	780	15

Table 1: R_L Resistance Value and C_L Capacitance Value Vs. Output Load Drive Capability

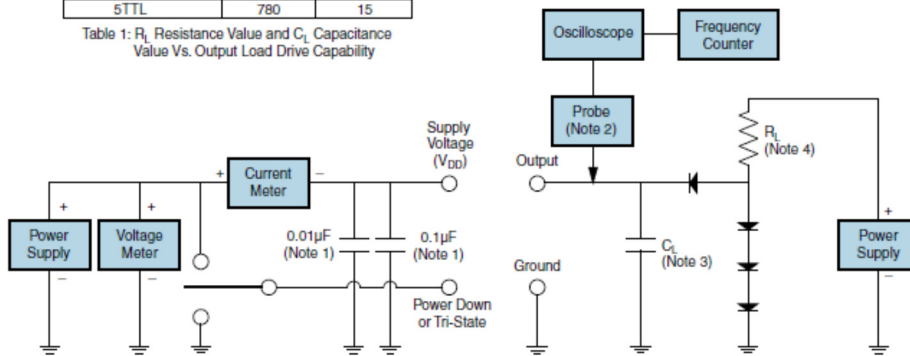

Note 1: An external 0.01µF ceramic bypass capacitor in parallel with a 0.1µF high frequency ceramic bypass capacitor close (less than 2mm) to the package ground and supply voltage pin is required.

Note 2: A low capacitance (<12pF), 10X attenuation factor, high impedance (>10Mohms), and high bandwidth (>300MHz) passive probe is recommended.

Note 3: Capacitance value C_L includes sum of all probe and fixture capacitance.

Note 4: Resistance value R_L is shown in Table 1. See applicable specification sheet for "Load Drive Capability".

Note 5: All diodes are MMBD7000, MMBD914, or equivalent.

CMOS Test Circuit

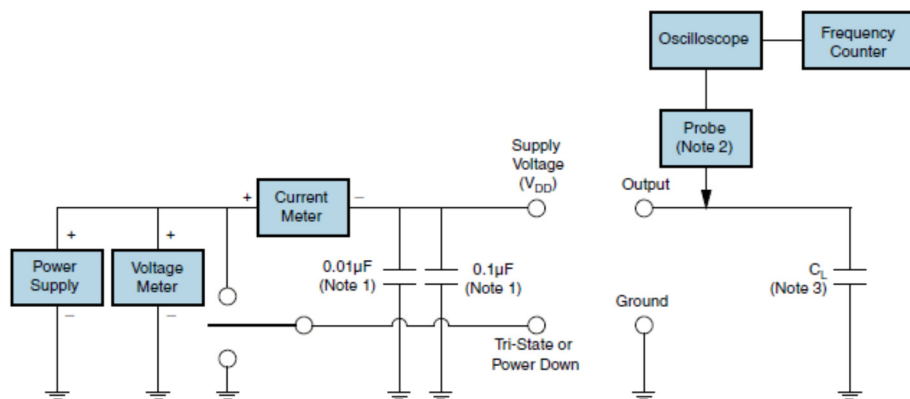

Note 1: An external 0.01µF ceramic bypass capacitor in parallel with a 0.1µF high frequency ceramic bypass capacitor close (less than 2mm) to the package ground and supply voltage pin is required.

Note 2: A low input capacitance (<12pF), 10X Attenuation Factor, High Impedance (>10Mohms), and High bandwidth (>300MHz) passive probe is recommended.

Note 3: Capacitance value (C_L) includes sum of all probe and fixture capacitance. See applicable specification sheet for "Load Drive Capability".

Solder Reflow Profile

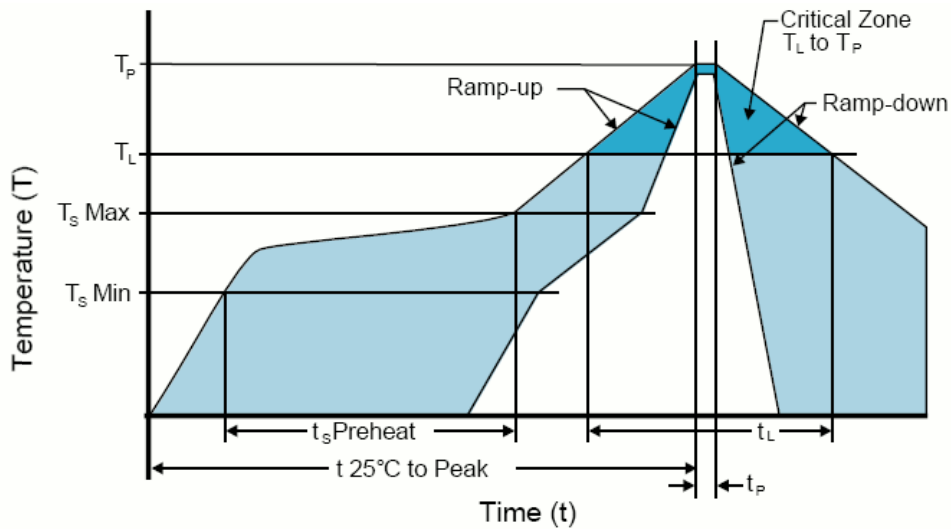

High Temperature Solder Bath (Wave Solder)

Note: Temperatures shown are applied to back of PCB board and device leads only. Do not use this method for product with the Gull Wing Option.

T_S MAX to T_L (Ramp-up Rate)	3°C/second Maximum
Preheat	
- Temperature Minimum (T _S MIN)	150°C
- Temperature Typical (T _S TYP)	175°C
- Temperature Maximum (T _S MAX)	200°C
- Time (t _S)	60 - 180 Seconds
Ramp-up Rate (T_L to T_P)	3°C/second Maximum
Time Maintained Above:	
- Temperature (T _L)	217°C
- Time (t _L)	60 - 150 Seconds
Peak Temperature (T_P)	260°C Maximum for 10 Seconds Maximum
Target Peak Temperature (T_P Target)	250°C +0/-5°C
Time within 5°C of actual peak (t_p)	20 - 40 seconds
Ramp-down Rate	6°C/second Maximum
Time 25°C to Peak Temperature (t)	8 minutes Maximum
Moisture Sensitivity Level	Level 1

Low Temperature Solder Bath (Wave Solder)

Note: Temperatures shown are applied to back of PCB board and device leads only. Do not use this method for product with the Gull Wing Option.

T_S MAX to T_L (Ramp-up Rate)	5°C/second Maximum
Preheat	
- Temperature Minimum (T _S MIN)	N/A
- Temperature Typical (T _S TYP)	150°C
- Temperature Maximum (T _S MAX)	N/A
- Time (t _S)	30 - 60 Seconds
Ramp-up Rate (T_L to T_P)	5°C/second Maximum
Time Maintained Above:	
- Temperature (T _L)	150°C
- Time (t _L)	200 Seconds Maximum
Peak Temperature (T_P)	245°C Maximum
Target Peak Temperature (T_P Target)	245°C Maximum 1 Time / 235°C Maximum 2 Times
Time within 5°C of actual peak (t_p)	5 seconds Maximum 1 Time / 15 seconds Maximum 2 Times
Ramp-down Rate	5°C/second Maximum
Time 25°C to Peak Temperature (t)	N/A
Moisture Sensitivity Level	Level 1

Low Temperature Infrared/Convection

Note: Temperatures shown are applied to body of device. Use this method only for product with the Gull Wing Option.

T_S MAX to T_L (Ramp-up Rate)	5°C/second Maximum
Preheat	
- Temperature Minimum (T _S MIN)	N/A
- Temperature Typical (T _S TYP)	150°C
- Temperature Maximum (T _S MAX)	N/A
- Time (t _S)	60 - 120 Seconds
Ramp-up Rate (T_L to T_P)	5°C/second Maximum
Time Maintained Above:	
- Temperature (T _L)	150°C
- Time (t _L)	200 Seconds Maximum
Peak Temperature (T_P)	185°C Maximum
Target Peak Temperature (T_P Target)	185°C Maximum 2 Times
Time within 5°C of actual peak (t_p)	10 seconds Maximum 2 Times
Ramp-down Rate	5°C/second Maximum
Time 25°C to Peak Temperature (t)	N/A
Moisture Sensitivity Level	Level 1

High Temperature Manual Soldering

Note: Temperatures listed are applied to device leads only. This method can be utilized with both Gull Wing and Non-Gull Wing devices.
260°C Maximum for 5 seconds Maximum, 2 times Maximum.

Low Temperature Manual Soldering

Note: Temperatures listed are applied to device leads only. This method can be utilized with both Gull Wing and Non-Gull Wing devices.
185°C Maximum for 10 seconds Maximum, 2 times Maximum.

1 - Build A Part Number

Select the parameters that meet your requirements and then click Next

Frequency in Megahertz (1 to 125):
Some frequencies within this range may not be available

Frequency Tolerance/Stability:

Operating Temperature Range:

Duty Cycle:

Pin 1 Connection:

Output Logic Type:

Cut Leads:

Gull Wing:

 Next

2 - Next Page

Access these Part Number specific resources and tools

 [P/N Specific Data Sheet](#)

 [Automated Quick Quote](#)

 [Request Sample](#)

 [Download IPC-1752](#)

 [My Parts List !\[\]\(f73ae0c51be0f12b632f1a2233deb626_img.jpg\)](#)

 [My Part Number !\[\]\(d0f1adf5b03caa5c76c18301bc7a33b9_img.jpg\)](#)

Part Numbering Guide

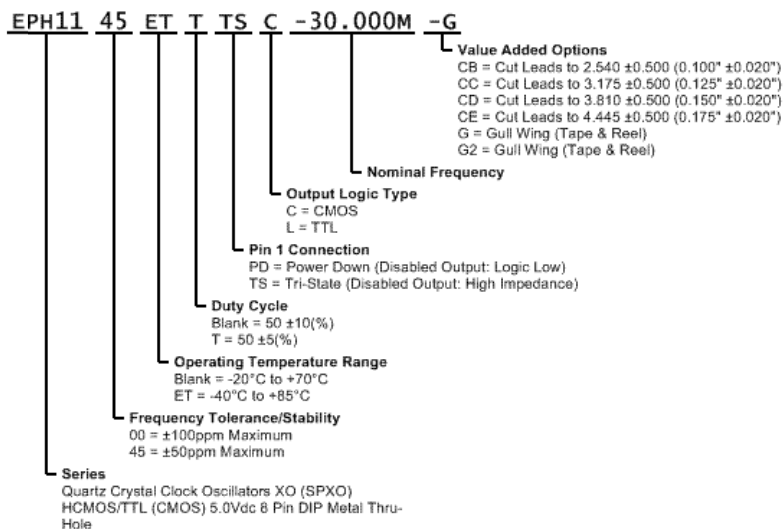

TOOLS

[Quick Quote](#)
[SmartSearch](#)
[Compliance Documents](#)
[Chipset Cross Reference](#)
[Competitor Cross Reference](#)

PRODUCT

[Crystals](#)
[Oscillators](#)
[Part Search](#)
[REACH Resources](#)
[RoHS Resources](#)
[End of Life](#)

ECLIPTEK

[Authorized Distributors](#)
[Contact](#)
[About](#)
[News](#)
[Our Quality](#)
[ISO9001](#)
[Feedback](#)

TERMS

[Privacy Policy](#)
[Terms of Sale](#)
[Legal](#)