

# IQXO-350 Commercial Oscillator

ISSUE 17; 1 SEPTEMBER 2001

## Delivery Options

- Common frequencies are available from stock, please contact our sales office for current leadtimes

## Output Compatibility

- HCMOS/TTL/LSTTL
- Drive Capability: 50pF or 10TTL (<70.0MHz)  
30pF (≥70.0 to 160.0MHz)  
(1.0 to < 100.0kHz 15pF or 10 LS TTL only)

## Package Outline

- 14-pin DIL compatible resistance welded enclosure, hermetically sealed with glass to metal seal. Available over 0 to 70°C (IQXO-350) or -40 to 85°C (IQXO-350I)

## Standard Frequency Stabilities

- ±25ppm, ±50ppm, ±100ppm  
(over operating temperature range)

## Operating Temperature Ranges

- 0 to 70°C (IQXO-350)
- 40 to 85°C (IQXO-350I)

## Storage Temperature Range

- 55 to 125°C

## Environmental Specification

- Terminal Strength: 0.91kg max. Force perpendicular to top & bottom
- Hermetic Seal: not to exceed  $1 \times 10^{-8}$  mBar litres of Helium leakage
- Solderability: MIL-STD-202E, Method 208C
- Vibration: 10 to 55Hz 0.76mm displacement, sweep 60 seconds, duration 2 hours
- Rapid Change of Temperature over Operating Temperature Range: 10 cycles
- Shock: 981m/s<sup>2</sup> for 6ms, three shocks in each direction along the three mutually perpendicular planes

## Marking

- Model number + Operating Temperature Code (if applicable)
- Frequency Stability Code
- Frequency Tolerance Code (Optional)
- Frequency
- Date Code (Year/Week)

## Minimum Order Information Required

- Frequency + Model Number + Operating Temperature (if applicable) + Frequency Stability

## Outline in mm

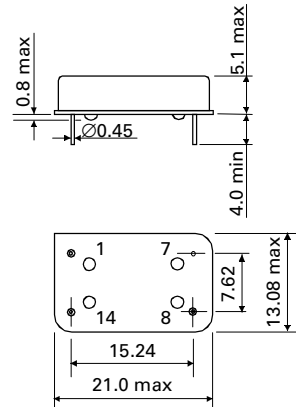

## Output Waveform - HCMOS/TTL

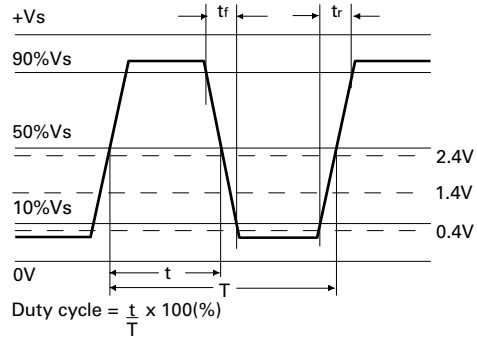

## Test Circuit - HCMOS

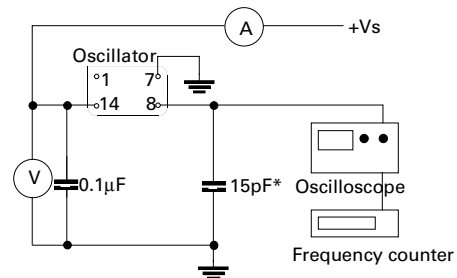

\*Inclusive of jigging & equipment capacitance

**Electrical Specifications - maximum limiting values when measured in HCMOS test circuit.**

Frequency Range	Frequency Stability	Supply Voltage	Supply Current	*Rise Time(t <sub>r</sub> )	*Fall Time(t <sub>f</sub> )	**Duty Cycle	Model Number
1.0 to < 100.0kHz	±25ppm, ±50ppm, ±100ppm	5V±0.25V	10mA	10ns	10ns	45/55%	IQX0-350, -350I
100.0 to < 250.0kHz	±25ppm, ±50ppm, ±100ppm	5V±0.25V	10mA	15ns	15ns	45/55%	IQX0-350, -350I
250.0kHz to < 5.0MHz	±25ppm, ±50ppm, ±100ppm	5V±0.25V	30mA	15ns	15ns	45/55%	IQX0-350, -350I
5.0 to < 16.0MHz	±25ppm, ±50ppm, ±100ppm	5V±0.25V	15mA	10ns	10ns	45/55%	IQX0-350, -350I
16.0 to < 30.0MHz	±25ppm, ±50ppm, ±100ppm	5V±0.25V	30mA	10ns	10ns	45/55%	IQX0-350, -350I
30.0 to < 50.0MHz	±25ppm, ±50ppm, ±100ppm	5V±0.25V	40mA	8ns	8ns	45/55%	IQX0-350, -350I
50.0 to < 70.0MHz	±25ppm, ±50ppm, ±100ppm	5V±0.25V	50mA	6ns	6ns	40/60%	IQX0-350, -350I
70.0 to 160.0MHz	±25ppm, ±50ppm, ±100ppm	5V±0.25V	70mA	5ns	5ns	40/60%	IQX0-350, -350I

**Ordering Example**  
 Frequency \_\_\_\_\_ 22.0MHz \_\_\_\_\_ IQX0-350I B  
 Model number: -350 \_\_\_\_\_  
 Operating Temperature Code: I = -40 to 85°C Not applicable for 0 to 70°C \_\_\_\_\_  
 Frequency Stability: A = ±25ppm, B = ±50ppm, C = ±100ppm \_\_\_\_\_

LEADED SPXDS

**Please note that the rise and fall times listed are the maximum values we specify to cover various frequency breaks. In practise the actual values are generally lower depending upon the spot frequency chosen. For typical values please contact our sales office.**

**Test Circuit - TTL**

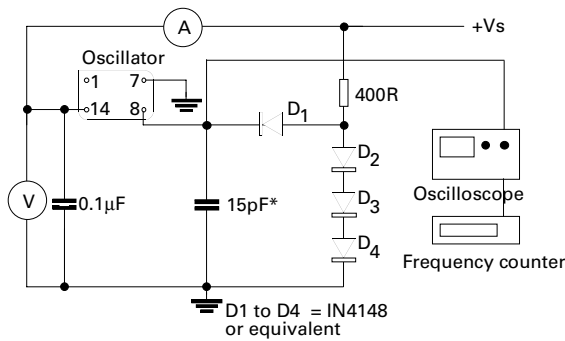

\*Inclusive of jiggig & equipment capacitance

**Test Circuit - LSTTL**

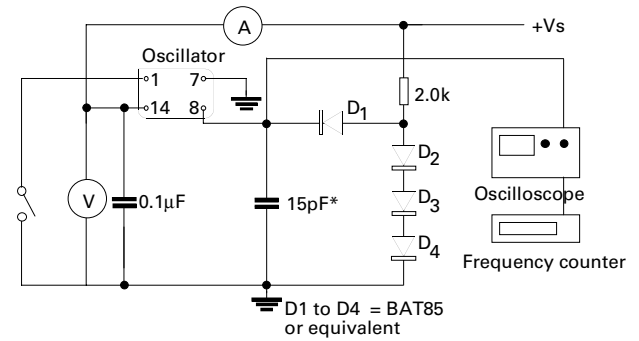

\*Inclusive of jiggig & equipment capacitance

Note: Pin 1 = No connection on non tri-state models

# STOCK OSCILLATORS

## Minimum Order Information Required

- Stock Number or Alpha Code

## IQXO-22 8-pin DIL Clock Oscillators - HCMOS/TTL

Frequency	Frequency Stability	Stock No.	Alpha Code	Packaging
1.84320MHz	±100ppm	SPX0003038	X361H	Bulk
3.68640MHz	±100ppm	SPX0003223	X363H	Bulk
4.0MHz	±100ppm	SPX0003155	X351H	Bulk
8.0MHz	±100ppm	SPX0003162	X352H	Bulk
10.0MHz	±100ppm	SPX0003168	X353H	Bulk
12.0MHz	±100ppm	SPX0003176	X354H	Bulk
12.2880MHz	±100ppm	SPX0003257	X379H	Bulk
14.318180MHz	±100ppm	SPX0003247	X373H	Bulk
14.74560MHz	±100ppm	SPX0003277	X388H	Bulk
16.0MHz	±100ppm	SPX0003182	X355H	Bulk
18.0MHz	±100ppm	SPX0003245	X372H	Bulk
20.0MHz	±100ppm	SPX0003189	X356H	Bulk
24.0MHz	±100ppm	SPX0003929	X371H	Bulk
24.5760MHz	±100ppm	SPX0003039	X386H	Bulk
25.0MHz	±100ppm	SPX0003280	X390H	Bulk
28.636360MHz	±100ppm	SPX0003254	X376H	Bulk
32.0MHz	±100ppm	SPX0003213	X360H	Bulk
32.7680MHz	±100ppm	SPX0003258	X380H	Bulk
40.0MHz	±100ppm	SPX0003197	X357H	Bulk
50.0MHz	±100ppm	SPX0003204	X358H	Bulk
60.0MHz	±100ppm	SPX0003260	X381H	Bulk
64.0MHz	±100ppm	SPX0003266	X384H	Bulk
80.0MHz	±100ppm	SPX0003279	X389H	Bulk
106.250MHz	±50ppm	SPX0009445	X453H	Bulk
125.0MHz	±50ppm	SPX0009446	X455H	Bulk

## IQXO-350 14-pin DIL Clock Oscillators - HCMOS/TTL

Frequency	Frequency Stability	Stock No.	Alpha Code	Packaging
1.0MHz	±100ppm	SPX0010197	X331B	Bulk
1.84320MHz	±100ppm	SPX0011520	X337B	Bulk
2.0MHz	±100ppm	SPX0000118	E618A	Bulk
3.68640MHz	±100ppm	SPX0010296	X325B	Bulk
4.0MHz	±100ppm	SPX0003154	X351A	Bulk
4.0960MHz	±100ppm	SPX0003246	X373A	Bulk
4.91520MHz	±100ppm	SPX0003222	X363A	Bulk
5.0MHz	±100ppm	SPX0011220	X333B	Bulk
6.0MHz	±100ppm	SPX0011505	X335B	Bulk
8.0MHz	±100ppm	SPX0003161	X352A	Bulk
9.83040MHz	±100ppm	SPX0003210	X359A	Bulk
10.0MHz	±100ppm	SPX0003167	X353A	Bulk
11.28960MHz	±100ppm	SPX0003263	X382A	Bulk
12.0MHz	±100ppm	SPX0003174	X354A	Bulk
12.2880MHz	±100ppm	SPX00010198	X342B	Bulk
14.74560MHz	±100ppm	SPX0010980	X388A	Bulk
16.0MHz	±100ppm	SPX0003181	X355A	Bulk
16.3840MHz	±50ppm	SPX0003236	X370A	Bulk
18.4320MHz	±100ppm	SPX0003228	X367A	Bulk
19.66080MHz	±100ppm	SPX0003225	X364A	Bulk
20.0MHz	±100ppm	SPX0003188	X356A	Bulk
24.0MHz	±100ppm	SPX0003238	X371A	Bulk
25.0MHz	±100ppm	SPX0010147	X350B	Bulk
30.0MHz	±100ppm	SPX0011178	X359B	Bulk
32.0MHz	±100ppm	SPX0003211	X360A	Bulk
32.7680MHz	±100ppm	SPX0010117	X380A	Bulk
33.330MHz	±100ppm	SPX0010220	X361B	Bulk
33.330MHz	±100ppm	SPX0003227	X366A	Bulk
40.0MHz	±50ppm	SPX0003196	X357B	Bulk
48.0MHz	±100ppm	SPX0010098	X373B	Bulk
50.0MHz	±100ppm	SPX0003203	X358A	Bulk
64.0MHz	±100ppm	SPX0011525	X393B	Bulk
66.0MHz	±100ppm	SPX0003232	X368A	Bulk

LEADED SPX0s