

Product Specification

SONET/SDH 10Gb/s DWDM XFP Optical Transceiver

FTRX-3812S3xx

PRODUCT FEATURES

- Supports 9.95Gb/s and 10.7Gb/s
- Hot-pluggable XFP footprint
- Temperature-stabilized DWDM EML transmitter
- 100GHz ITU Grid, C-Band
- Duplex LC connector
- Power dissipation <3.5W
- Built-in digital diagnostic functions
- Temperature range: -5°C to 70°C



APPLICATIONS

- Amplified DWDM 10G SONET/SDH

Finisar's FTRX-3812S3xx Small Form Factor 10Gb/s (XFP) transceiver complies with the current XFP Multi-Source Agreement (MSA) Specification¹. It supports amplified DWDM 10Gb/s SONET/SDH applications. Digital diagnostics functions are available via a 2-wire serial interface, as specified in the XFP MSA. For a multiprotocol version that supports 10G-Ethernet, please see FTRX-3812M3xx.

PRODUCT SELECTION

FTRX-3812S3xx

xx: 100GHz ITU-T channel
(see next page)

| Channel # | Product Code | Frequency (THz) | Center Wavelength (nm) |
|-----------|---------------|-----------------|------------------------|
| 17* | FTRX-3812S317 | 191.7 | 1563.86 |
| 18* | FTRX-3812S318 | 191.8 | 1563.05 |
| 19* | FTRX-3812S319 | 191.9 | 1562.23 |
| 20* | FTRX-3812S320 | 192.0 | 1561.42 |
| 21 | FTRX-3812S321 | 192.1 | 1560.61 |
| 22 | FTRX-3812S322 | 192.2 | 1559.79 |
| 23 | FTRX-3812S323 | 192.3 | 1558.98 |
| 24 | FTRX-3812S324 | 192.4 | 1558.17 |
| 25 | FTRX-3812S325 | 192.5 | 1557.36 |
| 26 | FTRX-3812S326 | 192.6 | 1556.55 |
| 27 | FTRX-3812S327 | 192.7 | 1555.75 |
| 28 | FTRX-3812S328 | 192.8 | 1554.94 |
| 29 | FTRX-3812S329 | 192.9 | 1554.13 |
| 30 | FTRX-3812S330 | 193.0 | 1553.33 |
| 31 | FTRX-3812S331 | 193.1 | 1552.52 |
| 32 | FTRX-3812S332 | 193.2 | 1551.72 |
| 33 | FTRX-3812S333 | 193.3 | 1550.92 |
| 34 | FTRX-3812S334 | 193.4 | 1550.12 |
| 35 | FTRX-3812S335 | 193.5 | 1549.32 |
| 36 | FTRX-3812S336 | 193.6 | 1548.51 |
| 37 | FTRX-3812S337 | 193.7 | 1547.72 |
| 38 | FTRX-3812S338 | 193.8 | 1546.92 |
| 39 | FTRX-3812S339 | 193.9 | 1546.12 |
| 40 | FTRX-3812S340 | 194.0 | 1545.32 |
| 41 | FTRX-3812S341 | 194.1 | 1544.53 |
| 42 | FTRX-3812S342 | 194.2 | 1543.73 |
| 43 | FTRX-3812S343 | 194.3 | 1542.94 |
| 44 | FTRX-3812S344 | 194.4 | 1542.14 |
| 45 | FTRX-3812S345 | 194.5 | 1541.35 |
| 46 | FTRX-3812S346 | 194.6 | 1540.56 |
| 47 | FTRX-3812S347 | 194.7 | 1539.77 |
| 48 | FTRX-3812S348 | 194.8 | 1538.98 |
| 49 | FTRX-3812S349 | 194.9 | 1538.19 |
| 50 | FTRX-3812S350 | 195.0 | 1537.40 |
| 51 | FTRX-3812S351 | 195.1 | 1536.61 |
| 52 | FTRX-3812S352 | 195.2 | 1535.82 |
| 53 | FTRX-3812S353 | 195.3 | 1535.04 |
| 54 | FTRX-3812S354 | 195.4 | 1534.25 |
| 55 | FTRX-3812S355 | 195.5 | 1533.47 |
| 56 | FTRX-3812S356 | 195.6 | 1532.68 |
| 57 | FTRX-3812S357 | 195.7 | 1531.90 |
| 58 | FTRX-3812S358 | 195.8 | 1531.12 |
| 59 | FTRX-3812S359 | 195.9 | 1530.33 |
| 60* | FTRX-3812S360 | 196.0 | 1529.55 |
| 61* | FTRX-3812S361 | 196.1 | 1528.77 |

*This channel is supported with limited availability -- Please contact Finisar for further details.

I. Pin Descriptions

| Pin | Logic | Symbol | Name/Description | Ref. |
|-----|-----------|-------------------------------|--|------|
| 1 | | GND | Module Ground | 1 |
| 2 | | VEE5 | Optional –5.2 Power Supply – Not required | |
| 3 | LVTTL-I | Mod-Desel | Module De-select; When held low allows the module to respond to 2-wire serial interface commands | |
| 4 | LVTTL-O | $\overline{\text{Interrupt}}$ | Interrupt (bar); Indicates presence of an important condition which can be read over the serial 2-wire interface | 2 |
| 5 | LVTTL-I | TX_DIS | Transmitter Disable; Transmitter laser source turned off | |
| 6 | | VCC5 | +5 Power Supply | |
| 7 | | GND | Module Ground | 1 |
| 8 | | VCC3 | +3.3V Power Supply | |
| 9 | | VCC3 | +3.3V Power Supply | |
| 10 | LVTTL-I | SCL | Serial 2-wire interface clock | 2 |
| 11 | LVTTL-I/O | SDA | Serial 2-wire interface data line | 2 |
| 12 | LVTTL-O | Mod_Abs | Module Absent; Indicates module is not present. Grounded in the module. | 2 |
| 13 | LVTTL-O | Mod_NR | Module Not Ready; Finisar defines it as a logical OR between RX_LOS and Loss of Lock in TX/RX. | 2 |
| 14 | LVTTL-O | RX_LOS | Receiver Loss of Signal indicator | 2 |
| 15 | | GND | Module Ground | 1 |
| 16 | | GND | Module Ground | 1 |
| 17 | CML-O | RD- | Receiver inverted data output | |
| 18 | CML-O | RD+ | Receiver non-inverted data output | |
| 19 | | GND | Module Ground | 1 |
| 20 | | VCC2 | +1.8V Power Supply | |
| 21 | LVTTL-I | P_Down/RST | Power Down; When high, places the module in the low power stand-by mode and on the falling edge of P_Down initiates a module reset Reset; The falling edge initiates a complete reset of the module including the 2-wire serial interface, equivalent to a power cycle. | |
| 22 | | VCC2 | +1.8V Power Supply | |
| 23 | | GND | Module Ground | 1 |
| 24 | PECL-I | RefCLK+ | Reference Clock non-inverted input, AC coupled on the host board – Not required | |
| 25 | PECL-I | RefCLK- | Reference Clock inverted input, AC coupled on the host board – Not required | |
| 26 | | GND | Module Ground | 1 |
| 27 | | GND | Module Ground | 1 |
| 28 | CML-I | TD- | Transmitter inverted data input | |
| 29 | CML-I | TD+ | Transmitter non-inverted data input | |
| 30 | | GND | Module Ground | 1 |

Notes:

1. Module circuit ground is isolated from module chassis ground within the module.
2. Open collector; should be pulled up with 4.7k – 10kohms on host board to a voltage between 3.15V and 3.6V.

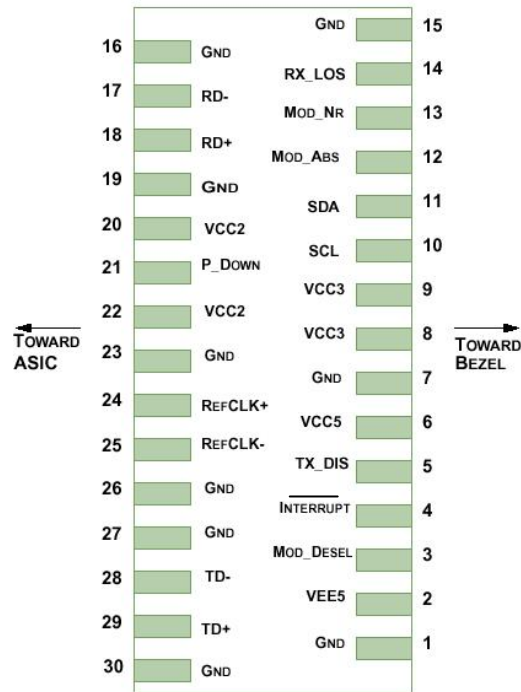

Diagram of Host Board Connector Block Pin Numbers and Names

II. Absolute Maximum Ratings

| Parameter | Symbol | Min | Typ | Max | Unit | Ref. |
|----------------------------|-------------------|------|-----|-----|------|------|
| Maximum Supply Voltage #1 | Vcc3 | -0.5 | | 4.0 | V | |
| Maximum Supply Voltage #2 | Vcc5 | -0.5 | | 6.0 | V | |
| Maximum Supply Voltage #3 | Vcc5 | -0.5 | | 2.0 | V | |
| Storage Temperature | T _S | -40 | | 85 | °C | |
| Case Operating Temperature | T _{OP} | -5 | | 70 | °C | |
| Receiver Damage Threshold | P _{Rdmg} | +1 | | | dBm | |

III. Electrical Characteristics ($T_{OP} = -5$ to 70 °C, $V_{CC5} = 4.75$ to 5.25 Volts)

| Parameter | Symbol | Min | Typ | Max | Unit | Ref. | |
|-------------------------------------|------------------------|-----------------------|---------|---------------------|------|------|---|
| Supply Voltage #1 | Vcc5 | 4.75 | | 5.25 | V | | |
| Supply Voltage #2 | Vcc3 | 3.13 | | 3.46 | V | | |
| Supply Voltage #3 | Vcc2 | 1.71 | | 1.89 | V | | |
| Supply Current – Vcc5 supply | Icc5 | | | 350 | mA | | |
| Supply Current – Vcc3 supply | Icc3 | | | 400 | mA | | |
| Supply Current – Vcc2 supply | Icc2 | | | 750 | mA | | |
| Module total power | P | | | 3.5 | W | 1 | |
| Transmitter | | | | | | | |
| Input differential impedance | R _{in} | | 100 | | Ω | 2 | |
| Differential data input swing | V _{in,pp} | 120 | | 820 | mV | | |
| Transmit Disable Voltage | V _D | 2.0 | | V _{cc} | V | 3 | |
| Transmit Enable Voltage | V _{EN} | GND | | GND+ 0.8 | V | | |
| Transmit Disable Assert Time | | | | 10 | us | | |
| Receiver | | | | | | | |
| Differential data output swing | V _{out,pp} | 340 | 650 | 850 | mV | 4 | |
| Data output rise time | t _r | | | 38 | ps | 5 | |
| Data output fall time | t _f | | | 38 | ps | 5 | |
| LOS Fault | V _{LOS fault} | V _{cc} – 0.5 | | V _{ccHOST} | V | 6 | |
| LOS Normal | V _{LOS norm} | GND | | GND+0.5 | V | 6 | |
| Power Supply Rejection | PSR | See Note 6 below | | | | | 7 |
| Reference Clock | | | | | | | |
| Clock differential input impedance | R _{clk,in} | | 100 | | Ω | | |
| Reference Clock frequency | f ₀ | | Baud/64 | | MHz | | |
| Differential clock input swing | V _{clk,pp} | 640 | | 1600 | mV | | |
| Clock output rise/fall time | t _{rf} | 200 | | 1250 | ps | 5 | |
| Reference clock frequency tolerance | Df | -100 | | +100 | PPM | | |

Notes:

1. Maximum total power value is specified across the full temperature and voltage range.
2. After internal AC coupling.
3. Or open circuit.
4. Into 100 ohms differential termination.
5. 20 – 80 %
6. Loss Of Signal is open collector to be pulled up with a 4.7k – 10kohm resistor to 3.15 – 3.6V. Logic 0 indicates normal operation; logic 1 indicates no signal detected.
7. Per Section 2.7.1. in the XFP MSA Specification¹.

IV. Optical Characteristics (EOL, $T_{OP} = -5$ to $70^{\circ}C$, $V_{CC5} = 4.75$ to 5.25 Volts)

Please note that the Transmitter of the FTRX-3811S3xx becomes operational within 60 seconds of power-up. This is due to the time required for the EML to reach its optimum operating temperature.

| Transmitter | | | | | | |
|---|-------------|--------------------|---|---|-----------------------------|------|
| Parameter | Symbol | Min | Typ | Max | Unit | Ref. |
| Output Opt. Pwr: 9/125 SMF | P_{OUT} | -3 | | +3 | dBm | |
| Optical Extinction Ratio | ER | 8.2 | | | dB | |
| Center Wavelength Spacing | | | 100 | | GHz | 1 |
| Transmitter Center Wavelength – End Of Life | λ_C | X-100 | X | X+100 | pm | 2 |
| Transmitter Center Wavelength – Beginning Of Life | λ_C | X-25 | X- | X+25 | pm | 2 |
| Sidemode Suppression ratio | SSR_{min} | 30 | | | dB | |
| Tx Jitter Generation (peak-to-peak) | T_{Xj} | | | 0.1 | UI | 3 |
| Tx Jitter Generation (RMS) | T_{XjRMS} | | | 0.01 | UI | 4 |
| Relative Intensity Noise | RIN | | | -130 | dB/Hz | |
| Receiver | | | | | | |
| Maximum Input Power | P_{MAX} | -7 | | | dBm | |
| Optical Center Wavelength | λ_C | 1270 | | 1600 | nm | |
| Receiver Reflectance | R_{rx} | | | -27 | dB | |
| LOS De-Assert | LOS_D | | | -30 | dBm | |
| LOS Assert | LOS_A | -37 | | | dBm | |
| LOS Hysteresis | | 0.5 | | | dB | |
| Receiver Sensitivity | | | | | | 5 |
| Data rate (Gb/s) | BER | Dispersion (ps/nm) | Sensitivity back-to-back at OSNR>30dB (dBm) | Power Penalty at OSNR>30dB (dB) | Threshold Adjustm. Required | |
| 9.95 | 1e-12 | -500 to 1450 | -23 | 3 | No | |
| 10.7 | 1e-4 | -500 to 1300 | -27 | 3 | Yes | |
| OSNR Performance | | | | | | 6 |
| Data rate (Gb/s) | BER | Dispersion (ps/nm) | Min OSNR Back-to-back at Power: -7 to -18dBm (dB) | Max OSNR Penalty at Power:-7 to -18dBm (dB) | Threshold Adjustm. Required | |
| 9.95 | 1e-12 | -500 to 1450 | 24 | 4 | No | |
| 10.7 | 1e-4 | -500 to 1300 | 16 | 4 | Yes | |

Notes:

1. Corresponds to approximately 0.8 nm.
2. X = Specified ITU Grid wavelength. Wavelength stability is achieved within 60 seconds of power up.
3. Measured with a host jitter of 50 mUI peak-to-peak.
4. Measured with a host jitter of 7 mUI RMS.
5. Measured at 1528-1600nm with worst ER; $BER < 10^{-12}$; PRBS31.
6. All OSNR measurements are performed with 0.1nm resolution.

V. General Specifications

| Parameter | Symbol | Min | Typ | Max | Units | Ref. |
|----------------------------|------------------|------|-----|------|-------|------|
| Bit Rate | BR | 9.95 | | 10.7 | Gb/s | 1 |
| Max. Supported Link Length | L _{MAX} | | 80 | | km | |

Notes:

1. Amplified SONET OC-192, SONET OC-192 with FEC.

VI. Environmental Specifications

Finisar XFP transceivers have an operating temperature range from -5°C to +70°C case temperature.

| Parameter | Symbol | Min | Typ | Max | Units | Ref. |
|----------------------------|------------------|-----|-----|-----|-------|------|
| Case Operating Temperature | T _{op} | -5 | | 70 | °C | |
| Storage Temperature | T _{sto} | -40 | | 85 | °C | |

VII. Regulatory Compliance

Finisar XFP transceivers are Class 1 Laser Products. They are certified per the following standards:

| Feature | Agency | Standard | Certificate Number |
|-------------------|----------|--|--------------------|
| Laser Eye Safety | FDA/CDRH | CDRH 21 CFR 1040 and Laser Notice 50 | 9210176-71 |
| Laser Eye Safety | TÜV | EN 60825-1: 1994+A11:1996+A2:2001 IEC 60825-1: 1993+A1:1997+A2:2001 IEC 60825-2: 2000, Edition 2 | R72052602 |
| Electrical Safety | TÜV | EN 60950 | R72052602 |
| Electrical Safety | UL/CSA | CLASS 3862.07 CLASS 3862.87 | 1439230 |

Copies of the referenced certificates are available at Finisar Corporation upon request.

VIII. Digital Diagnostics Functions

As defined by the XFP MSA¹, Finisar XFP transceivers provide digital diagnostic functions via a 2-wire serial interface, which allows real-time access to the following operating parameters:

- Transceiver temperature
- Laser bias current
- Transmitted optical power
- Received optical power
- Transceiver supply voltage
- TEC Temperature

It also provides a sophisticated system of alarm and warning flags, which may be used to alert end-users when particular operating parameters are outside of a factory-set normal range.

The operating and diagnostics information is monitored and reported by a Digital Diagnostics Transceiver Controller (DDTC) inside the transceiver, which is accessed through the 2-wire serial interface. When the serial protocol is activated, the serial clock signal (SCL pin) is generated by the host. The positive edge clocks data into the XFP transceiver into those segments of its memory map that are not write-protected. The negative edge clocks data from the XFP transceiver. The serial data signal (SDA pin) is bi-directional for serial data transfer. The host uses SDA in conjunction with SCL to mark the start and end of serial protocol activation. The memories are organized as a series of 8-bit data words that can be addressed individually or sequentially. The 2-wire serial interface provides sequential or random access to the 8 bit parameters, addressed from 000h to the maximum address of the memory.

For more detailed information, including memory map definitions, please see the XFP MSA documentation¹.

Receiver Threshold Adjustment

The FTRX-3812S3xx provides access to receiver decision threshold adjustment via the 2-wire serial interface, in order to improve receiver OSNR performance based on specific link conditions. It is implemented as follows:

- Rx Threshold of XFP transceivers will be factory-set for optimized performance in non-FEC applications. This will be the default value during both cold start (power-up) and warm start (module reset).
- The transceiver supports adjustment of Rx Threshold value by the host through register 76d, table 01h. This is intended to be used in FEC applications.

- Register 76d, table 01h is a volatile memory. Therefore if the transceiver is power-cycled, the register starts up with a value of 00h which corresponds to the default Rx Threshold value.
- The threshold adjustment input value is 2's complement 7 bit value (-128 to +127), with 0 corresponding to default Rx threshold value. Full range of adjustment provides at least a $\pm 10\%$ change in Rx threshold from the default value.

IX. Mechanical Specifications

Finisar's XFP transceivers are compliant with the dimensions defined by the XFP Multi-Sourcing Agreement (MSA).

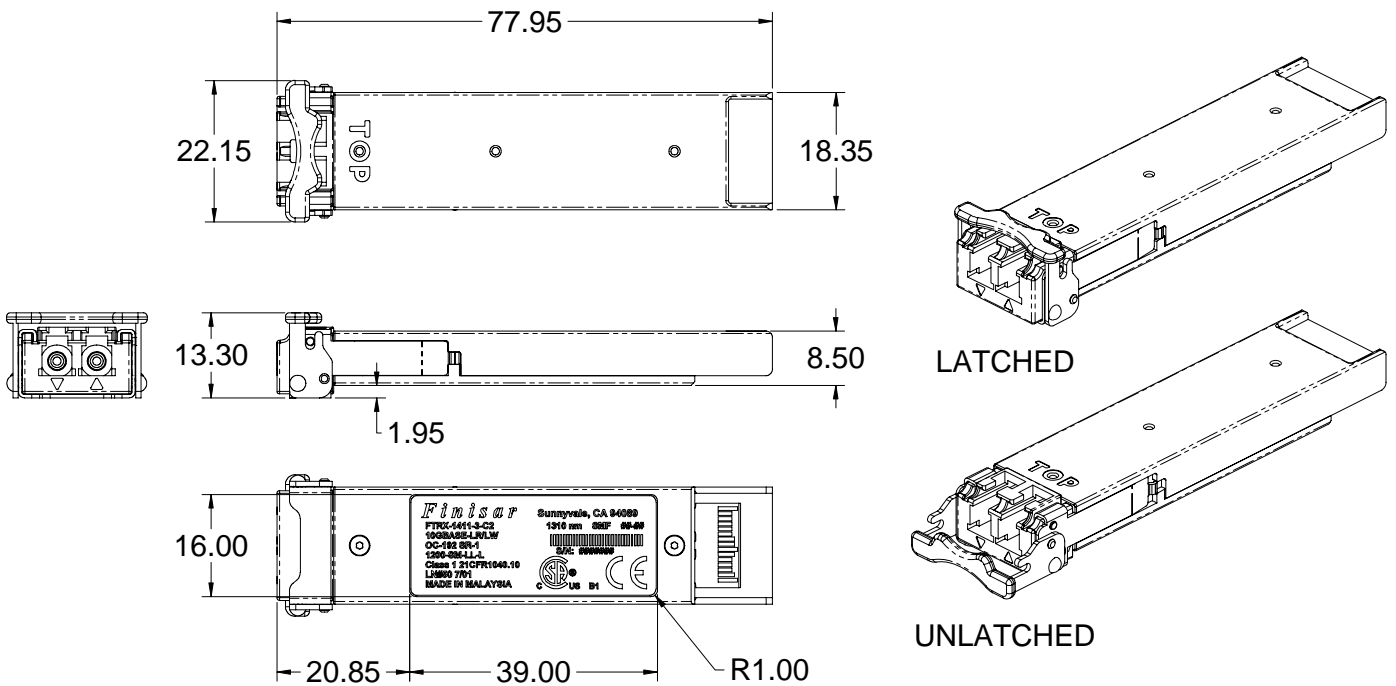

XFP Transceiver (dimensions are in mm)

X. PCB Layout and Bezel Recommendations

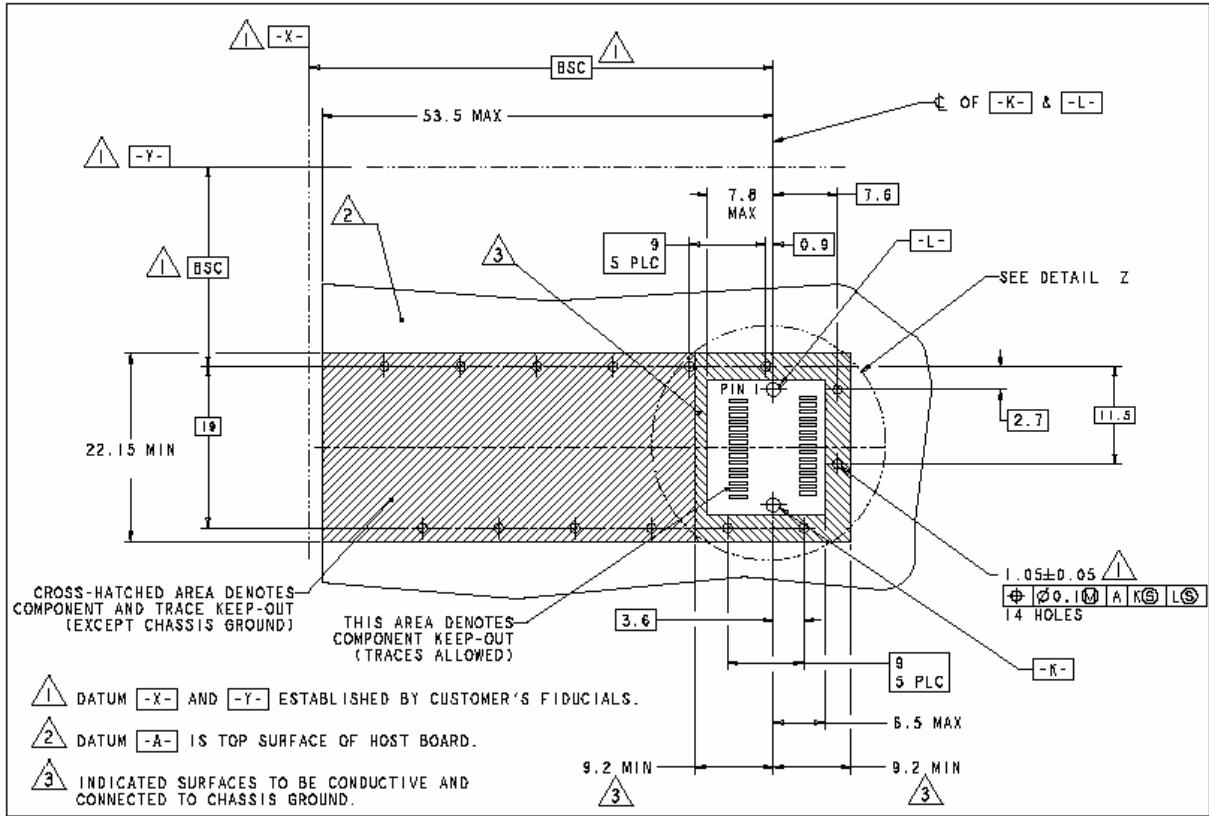

XFP Host Board Mechanical Layout (dimensions are in mm)

XI. References

1. 10 Gigabit Small Form Factor Pluggable Module (XFP) Multi-Source Agreement (MSA), Rev 4.5 – August 2005. Documentation is currently available at <http://www.xfpmsa.org/>

XII. For More Information

Finisar Corporation
1389 Moffett Park Drive
Sunnyvale, CA 94089-1133
Tel. 1-408-548-1000
Fax 1-408-541-6138
sales@finisar.com
www.finisar.com