

SYNCHRO/RESOLVER-TO-DIGITAL CONVERTERS

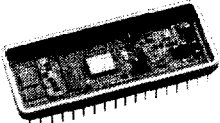

DESCRIPTION

The SD-14595 is a low-cost, high reliability, synchro- or resolver-to-digital converter with 14-bit-only, 16-bit-only or pin programmable 14-bit or 16-bit resolution. Packaged in a 36-pin DDIP, the SD-14595/96/97 series feature Built-In-Test (BIT) output.

The SD-14595/96/97 series accepts broadband inputs: 360 to 1 kHz. Other features are solid-state signal and reference isolation and high common mode rejection. In addition, the SD-14596 and SD-14597 are pin-for-pin replacements for the Natel 1044 and 1046, respectively.

The digital angle output from the SD-14595/96/97 is a natural binary code, parallel positive logic and is TTL/CMOS compatible. The SD-

14595/96/97 accomplishes synchronization to a computer with the Converter Busy (CB) output and/or the Inhibit (INH) input.

APPLICATIONS

Because of its high reliability, small size, and low power consumption, the SD-14595/96/97 is ideal for military ground or avionics applications. All models are available with MIL-PRF-38534 processing.

Designed with three-state output, the SD-14595/96/97 is especially well-suited for use with computer based systems. Among the many possible applications are radar and navigation systems, fire control systems, flight instrumentation, and flight trainers or simulators.

FEATURES

- **Single +5 V Power Supply**
- **Accuracy to 1.3 Arc Minutes**
- **Pin Programmable 14 Bit/16 Bit, 14 Bit Only or 16 Bit Only**
- **No 180° False Lock-up**
- **Internal Synthesized Reference**
- **Built-In-Test (BIT) Output**
- **Low Power**
- **Pin-for-Pin Replacement for Natel's 1044 and 1046**

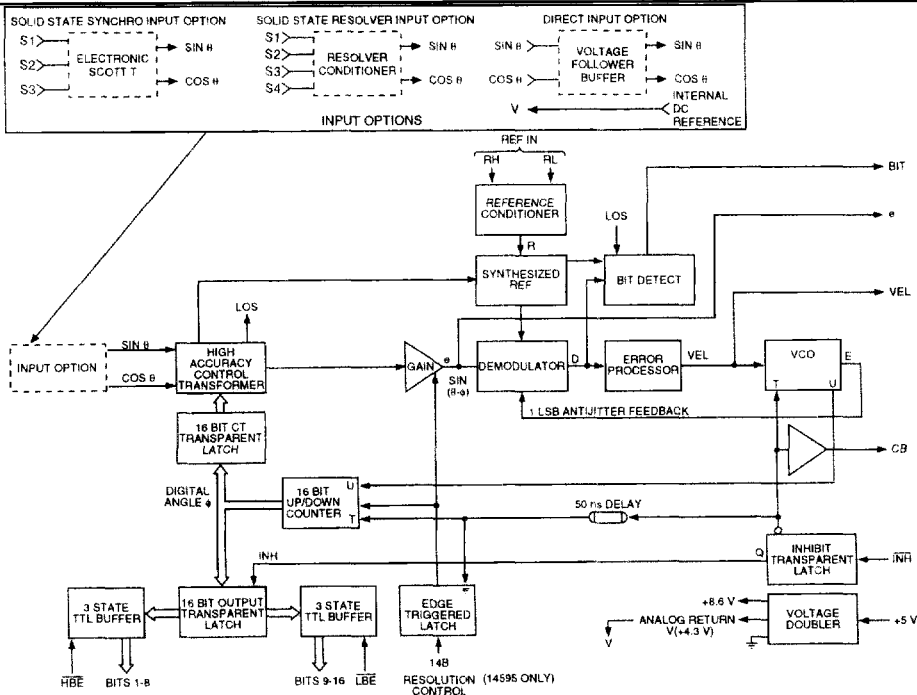

SD-14595/96/97 BLOCK DIAGRAM

SD-14595/96/97 SPECIFICATIONS		
Specifications apply over temperature range, power supply range, reference frequency, and amplitude range; 15% signal amplitude variation, up to 10% harmonic distortion in the reference, and up to 45° of signal to reference phase shift.		
PARAMETER	UNIT	VALUE
RESOLUTION	Bits	14 or 16
ACCURACY	Min	5.2, 2.6, or 1.3
REPEATABILITY	LSB	1 max
REFERENCE INPUT CHARACTERISTICS		
Carrier Frequency Range	Hz	47-1000 (60 Hz Unit)
Voltage Range	Vrms	360-1000 (400 Hz Unit) 4-130 (for 11.8 V or 90 V signal input) 3-100 (for 1 V direct signal input)
input Impedance:		
■ Single Ended	Ohm	250k min
■ Differential	Ohm	500k min
Common Mode Range	V	250 peak max
SIGNAL INPUT CHARACTERISTICS (voltage options and minimum input impedance)		
Input Impedance Imbalance	%	0.2 max
■ Synchro	V	<u>11.8 V L-L</u> <u>90 V L-L</u>
• Zin Line-to-Line	Ohm	17.5k 130k
• Zin Each Line-to-Gnd	Ohm	11.5k 85k
• Common Mode Range	V	
■ Resolver	V	<u>11.8 V L-L</u>
• Zin Single Ended	Ohm	23k
• Zin Differential	Ohm	46k
• Zin Each Line-to-Gnd	Ohm	23k
• Common Mode Range	V	60 max
■ Direct (1.0 V L-L)		
• Input Signal Type		
• Sin/Cos Voltage Range	Vrms	Sin and Cos resolver signals referenced to converter internal DC reference V.
• Max Voltage w/o Damage		1 V nominal, 1.15 V max 15 V continuous 100 V Peak Transient
• Input Impedance	Ohm	Zin > 20M // 10 pf voltage follower
REFERENCE SYNTHESIZER ± Sig/Ref Phase Shift		
	Deg	60 typ, 45 guaranteed
DIGITAL INPUT/OUTPUT Logic Type		
		TTL/CMOS compatible
Inputs:		
Inhibit ($\overline{\text{INH}}$)		Logic 0 = 0.8 V max Logic 1 = 2.0 V min Loading = 30 μ A max Logic 0 inhibits Data stable within 0.5 μ s (pull up) Logic 1 for 14 bits Logic 0 for 16 Bits Pull-up current source to +5 V/5 pF max CMOS transient protected Logic 0 enables Data Valid within 150 ns Logic 1 = High Z Data High Z within 100 ns Pull-down current source to GND/5 pF max CMOS transient protected
Resolution Control (14B) (for Programmable Units Only)		
Enable Bits 1 to 8 ($\overline{\text{HBE}}$) Enable Bits 9 to 16 (LBE) (9 to 14 for 14-bit mode)		

SD-14595/96/97 SPECIFICATIONS (CONTD)		
PARAMETER	UNIT	VALUE
DIGITAL INPUT/OUTPUT (continued)		
Outputs:		
Parallel Data	Bits	14 or 16 parallel lines; natural binary angles, positive logic
Converter Busy (CB)		0.8 to 3.0 μ s positive pulse; leading edge initiates counter update.
BIT		Logic 1 for fault conditions.
Drive Capability		50 pF + rated logic drive Logic 0; 1 TTL load, 1.6 mA at 0.4 V max Logic 1; 10 TTL loads, 0.4 mA at 2.8 V min High Z; 10 μ A/5 pF max Logic 0; 100 mV max driving CMOS Logic 1; +5 V supply minus 100 mV min driving CMOS
ANALOG OUTPUT		
Analog Return (V)		+4.3 V nom
Velocity (VEL) (See note 3.)		See TABLE 4..
AC error (e)		
■ 14-Bit Mode	mV _{rms}	3.5 per LSB of error
■ 16-Bit Mode	mV _{rms}	1.75 per LSB of error
Load	mA	1
DYNAMIC CHARACTERISTICS		
		See TABLE 6.
POWER SUPPLY CHARACTERISTICS		
Nominal Voltage	V	+5
Voltage Tolerance	%	±10
Max Voltage w/o Damage	V	+7
Current	mA	25 max+digital output load
TEMPERATURE RANGES		
Operating (-1XX or -4XX)	°C	-55 to +125
(-3XX or -8XX)	°C	0 to 70
Storage	°C	-65 to +150
PHYSICAL CHARACTERISTICS		
Size	in (mm)	1.9 x 0.78 x 0.21 (48 x 20 x 5.3) 36 Pin Double Dip
Weight	oz(g)	0.7 max (20)
TRANSFORMER CHARACTERISTICS (See ordering information for list of Transformers. Reference Transformers are Optional for Both Solid-State and Voltage Follower Input Options.) 400 Hz TRANSFORMERS Reference Transformer		
Carrier Frequency Range		360 - 1000 Hz
Voltage Range		18 - 130 V
Input Impedance		40 k Ω min
Breakdown Voltage to GND		1200 V peak
Signal Transformer		
Carrier Frequency Range		360-1000 Hz
Breakdown Voltage to GND		700 V peak

SD-14595/96/97 SPECIFICATIONS (CONTD)

PARAMETER	VALUE		
Minimum Input impedances (Balanced)	SynchroZ _{IN} (Z _{SO})	ResolverZ _{IN}	
	90 V L-L	180 Ω	100 kΩ
	26 V L-L	-	30 kΩ
11.8 V L-L	20 kΩ	30 kΩ	
60 Hz TRANSFORMERS			
Reference Transformer	47 - 440 Hz		
Carrier Frequency Range	80 - 138 V rms; 115 V rms nominal resistive		
Input Voltage Range	600 kΩ min, resistive		
Input Impedance	500 V rms transformer isolated		
Input Common Mode Voltage			
Output Description	+R (in phase with RH-RL) and -R (in phase with RL- RH) derived from op-amps. Short-Circuit proof.		
Output Voltage	3.0 V nominal riding on ground reference V. Output Voltage level tracks input level.		
Power Required	4 mA typ, 7 mA max from +15 V supply.		
Signal Transformer	47 - 440 Hz		
Carrier Frequency Range	10 - 100 V rms L- L; 90 V rms L- L nominal		
Input Voltage Range	148 kΩ min L- L balanced resistive		
Input Impedance	±500 V rms, transformer isolated		
Input Common Mode Voltage	Resolver output,		
Output Description	- sine (- S) + Cosine (+C) derived from op-amps. Short circuit proof.		
Output Voltage	1.0 V rms nominal riding on ground reference V. Output voltage level tracks input level.		
Power Required	4 mA typ, 7 mA max from +15 V supply.		

Note:

- (1) Pin Programmable.
- (2) See TABLE 7.
- (3) VEL polarity is negative voltage for positive angular rate

400 Hz SYNCHRO TRANSFORMER T1 21044 OR 21045

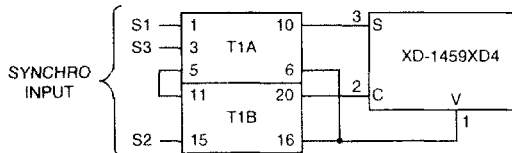

400 Hz RESOLVER TRANSFORMER T1 21046 OR 21047 OR 21048

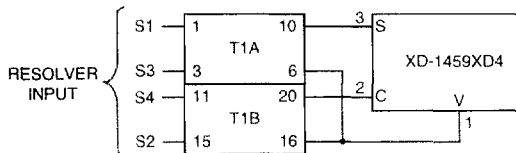

60 Hz SYNCHRO TRANSFORMER 24126

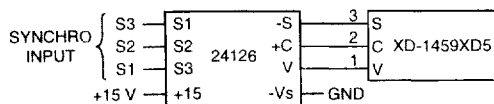

400 Hz REF TRANSFORMER 21049

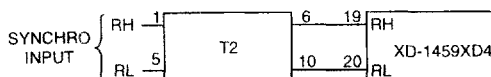

60 Hz REF TRANSFORMER 24133

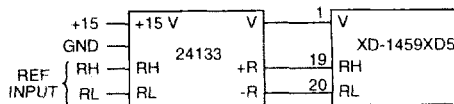

TRANSFORMER CONNECTION DIAGRAM

These external transformers are for use with converter modules with voltage follower buffer inputs.

400 Hz SYNCHRO AND RESOLVER TRANSFORMER DIAGRAMS (T1A AND T1B)
 EACH TRANSFORMER CONSISTS OF TWO SECTIONS, T1A AND T1B

1. MECHANICAL OUTLINES

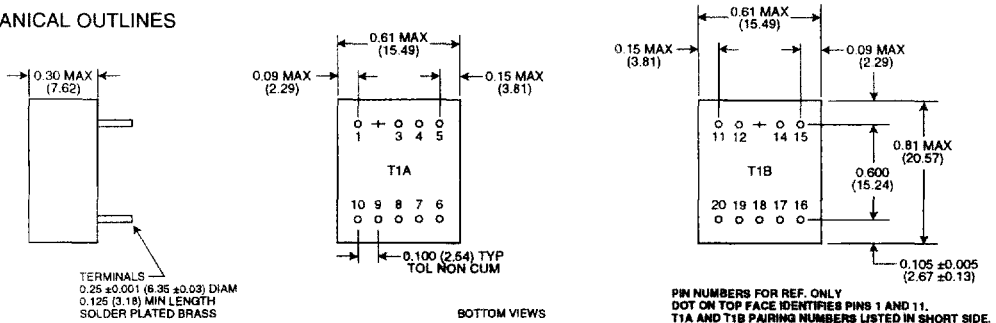

2. SCHEMATIC DIAGRAMS

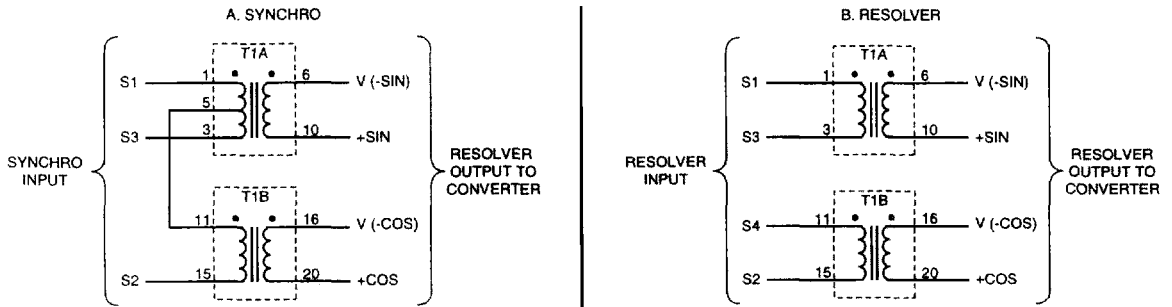

400 Hz REFERENCE TRANSFORMER DIAGRAMS (T2)

1. MECHANICAL OUTLINE

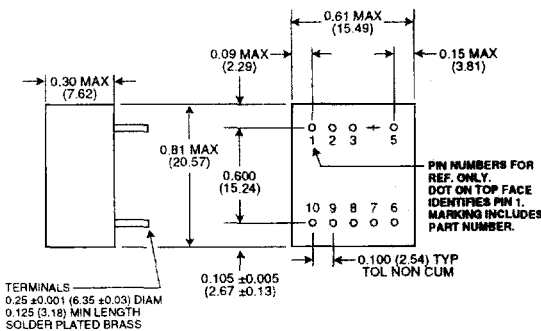

2. SCHEMATIC DIAGRAM

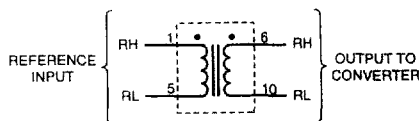

60 Hz SYNCHRO AND REFERENCE TRANSFORMER DIAGRAMS

The mechanical outline is the same for the synchro input transformer (24126) and the reference input transformer (24133), except for the pins. Pins for the reference transformer are shown in parenthesis () below. An asterisk (*) indicates that the pin is omitted.

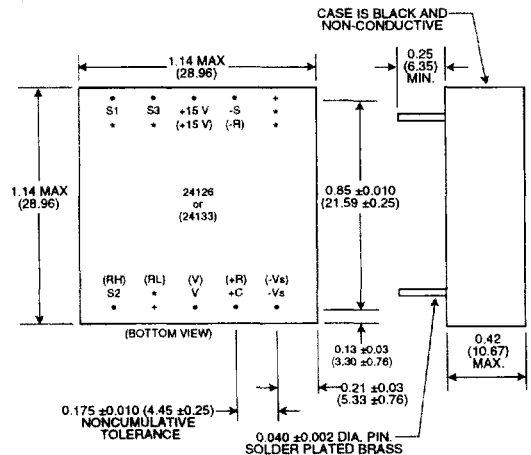

TRANSFORMER MECHANICAL OUTLINES

SD-14595/96/97 PINOUTS

PIN	FUNCTION	PIN	FUNCTION
1	S1(Res) S1(Syn) -----	36	+5 V
2	S2(Res) S2(Syn) Cos(x)	35	HBE
3	S3(Res) S3(Syn) Sin(x)	34	B1 (MSB)
4	S4(Res) -----	33	B2
5	N/C	32	B3
6	N/C	31	B4
7	N/C	30	B5
8	RL	29	B6
9	RH	28	B7
10	VEL	27	B8
11	Analog Return (V)	26	B9
12	e	25	B10
13	INH	24	B11
14	CB	23	B12
15	BIT	22	B13
16	14B (14595 only)	21	B14
17	LBE	20	B15
18	GND	19	B16 (LSB)

E

Note: "(Res)" means resolver, "(Syn)" means synchro, and "(x)" means direct.

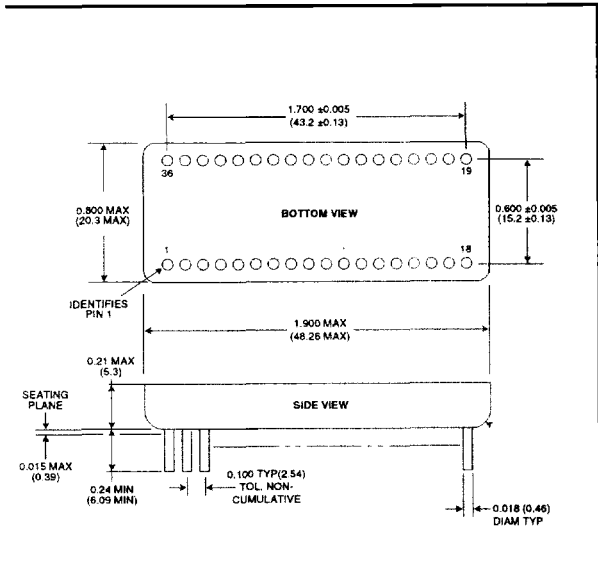

NOTES:

1. Dimensions shown are in inches (mm).
2. Lead identification numbers are for reference only.
3. Lead cluster shall be centered within $\pm 0.01(0.25)$ of outline dimensions. Lead spacing dimensions apply only at seating plane.
4. Package is kovar with electroless nickel plating.
5. Case is electrically floating.
6. Leads are gold coated kovar.

SD-14595/96/97 MECHANICAL OUTLINE
36-PIN DDIP (KOVAR)

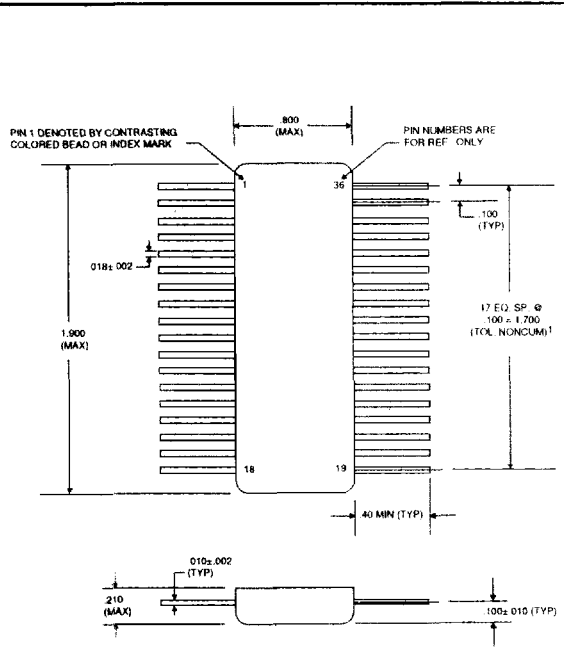

Note: Lead Cluster to be centralized about case centerline within ± 0.10

SD-14595/96/97 MECHANICAL OUTLINE
36-PIN FLAT PACK (CERAMIC)

ORDERING INFORMATION

XX-1459XXX-XXXX

Supplemental Process Requirements:

- S = Pre-Cap Source Inspection
- L = Pull Test
- Q = Pull Test and Pre-Cap Inspection
- Blank = None of the Above

Accuracy:

- 2 = ±5.2 Minutes
- 4 = ±2.6 Minutes
- 5 = ±1.3 Minutes (16 Bit only)

Process Requirements:

- 0 = Standard DDC Processing, no Burn-In (See page xiii.)
- 1 = MIL-PRF-38534 Compliant
- 2 = B*
- 3 = MIL-PRF-38534 Compliant with PIND Testing
- 4 = MIL-PRF-38534 Compliant with Solder Dip
- 5 = MIL-PRF-38534 Compliant with PIND Testing and Solder Dip
- 6 = B* with PIND Testing
- 7 = B* with Solder Dip
- 8 = B* with PIND Testing and Solder Dip
- 9 = Standard DDC Processing with Solder Dip, no Burn-In (See page xiii.)

Temperature Grade/Data Requirements:

- 1 = -55°C to +125°C
- 2 = -40°C to +85°C
- 3 = 0°C to +70°C
- 4 = -55°C to +125°C with Variables Test Data
- 5 = -40°C to +85°C with Variables Test Data
- 8 = 0°C to +70°C with Variables Test Data

Input:

- 1 = 11.8/400 Hz
- 2 = 90/400 Hz
- 3 = 90/60 Hz
- 4 = Direct/400 Hz
- 5 = Direct/60 Hz

Package:

- D = DIP
- F = Flat Pack (Consult factory for availability.)

Resolution:

- 5 = Programmable (14 or 16 Bits)
- 6 = 14 Bit
- 7 = 16 Bit

Input Type:

- RD = Resolver Input
- SD = Synchro Input
- XD = Direct Input

*Standard DDC Processing with burn-in and full temperature test — see table on page xiii.

TRANSFORMER ORDERING INFORMATION

Reference and signal transformers for the voltage follower buffer input converters must be ordered separately from the table.

Table Notes:

* The part number for each 400 Hz synchro or resolver isolation transformer includes two separate modules as shown in the outline drawings.

† 60 Hz synchro transformers are available in two temperature ranges:

- 1 = -55°C to +105°C
- 3 = 0°C to +70°C

A-ABR

TYPE	FREQ.	REF. VOLTAGE	L-L VOLTAGE	PART NUMBERS	
				REF. XFMR	SIGNAL XFMR
Synchro	400 Hz	115 V	90 V	21049	21045*
Synchro	400 Hz	26 V	11.8 V	21049	21044*
Resolver	400 Hz	115 V	90 V	21049	21048*
Resolver	400 Hz	26 V	26 V	21049	21047*
Resolver	400 Hz	26 V	11.8 V	21049	21046*
Synchro†	60 Hz	115 V	90 V	24133-1 24133-3	24126-1 24126-3