

# 7273 SERIES $\phi$ 2.5 EARPHONE JACK

## MATERIAL

HOUSING: THERMOPLASTIC (UL94 V-0)

HOUSING COLOR: BLACK

SHELL: COPPER ALLOY

PIN1,PIN3,PIN4: COPPER ALLOY

CONTACT&SHELL PLATING: SEE ORDER INFORMATION

REV	DATE	DESCRIPTION	ECN NO.	NAME
A	03.04.22	NEW RELEASE		WPENG
B	03.05.24	$\Delta$ ADD SPEC	AK0305008	ANLG
C	03.05.28	$\Delta$ MODIFY	AK0305010	ANLG
D	04.05.07	$\Delta$ MODIFY	AK0405002	WSANMIN
E	04.07.21	$\Delta$ MODIFY	AK0407012	WSANMIN
F	04.10.25	$\Delta$ MODIFY DIMENSION	AK0410023	LSJ
G	04.11.25	$\Delta$ MODIFY DIMENSION	AK0411023	SCREW

### ORDER INFORMATION

\* 7273- 05 \*\* \* CONTACT PLATING: 1:1u" Au(STANDARD) PLATED  
 $\Delta$  2:Ag PLATED  
 3:LIGHT Sn PLATED  
 4:3u" Au  
 5:15u" Au

$\Delta$  0:1.3.4.5  
 1:3.4.5  
 $\Delta$  0:NO MARK  
 1:WITH WIESON MARK

"": NORMAL PRODUCT  
 "G": GREEN PRODUCT

SHELL PLATING: 0:1u" Au(STANDARD) PLATED  
 $\Delta$  1:Ag PLATED  
 2:LIGHT Sn PLATED

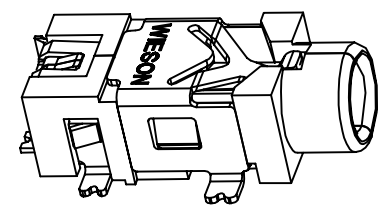
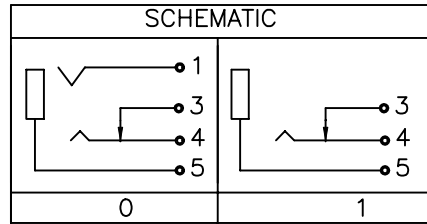
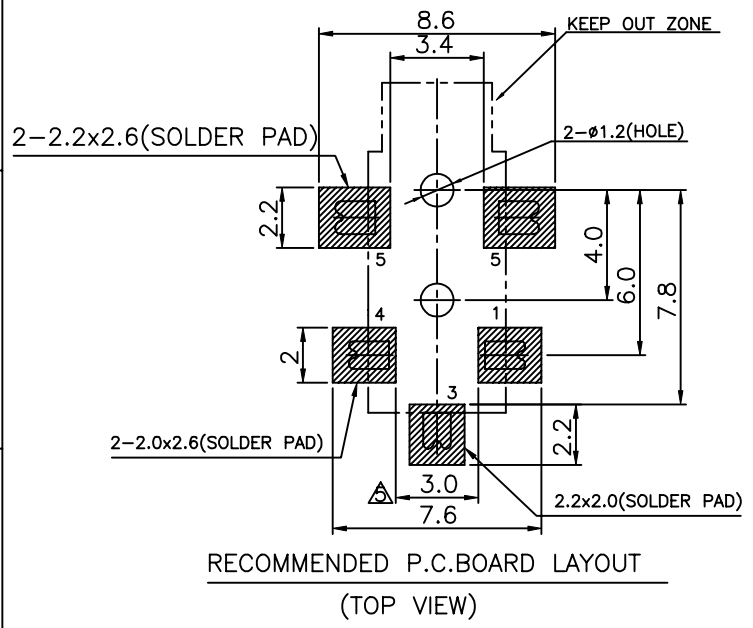
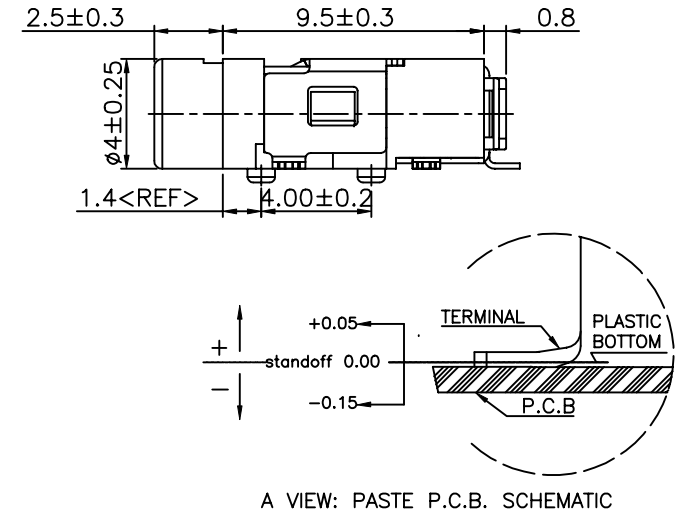
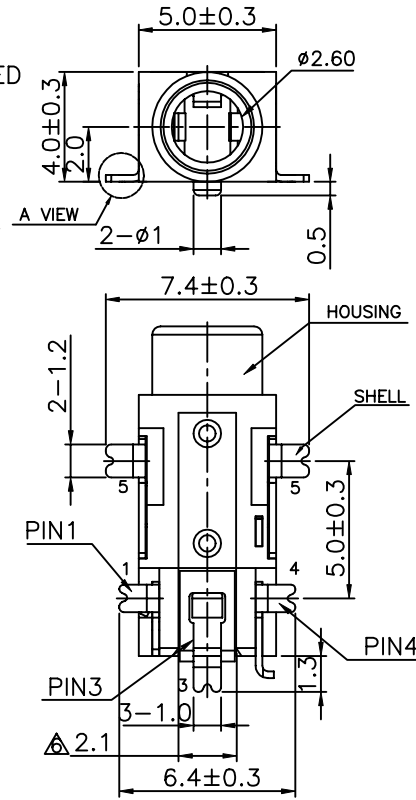

NOTE: 1. P.C.B LAYOUT TOLERANCE:  $\pm$ 0.05mm  
 2. COPLANARITY TOLERANCE MAX: 0.13mm

GENERAL TOLERANCE $\pm$ 0.20MM	WIESON TECHNOLOGIES CO., LTD	PART NO.: *7273-05****	
		DRAWN BY: WPENG(WSC)	DRAWING NO. *7273-05****
GENERAL ANGLE TOLERANCE $\pm$ 2°	CHECKED BY: JIMMY	DRAWING SIZE	A4
	APPROVED BY: JERRY	UNIT	mm
	SORTING NO.: WSC	PAGE	1 OF 1

ISSUED

[ARTICLE:044033 V4]