

# Arithmetic Logic Unit/ Function Generator

# SN74S381

## Features/Benefits

- A fully parallel 4-bit ALU
- Ideally suited for high-speed processors
- Generate and propagate outputs for full carry lookahead
- Three arithmetic functions
- Three logic functions
- Preset and clear functions

## Ordering Information

PART NUMBER	PACKAGE	TEMPERATURE
SN74S381	N, J	Commercial

## Description

The 'S381 is a Schottky TTL arithmetic logic unit (ALU)/function generator that performs eight binary arithmetic/logic operations on two 4-bit words as shown in the function table. These operations are selected by the three function-select lines (S0, S1, S2). A full lookahead carry circuit is provided for fast, simultaneous carry generation by means of two cascaded outputs (P and G) for the four bits in the package.

## Pin Configuration

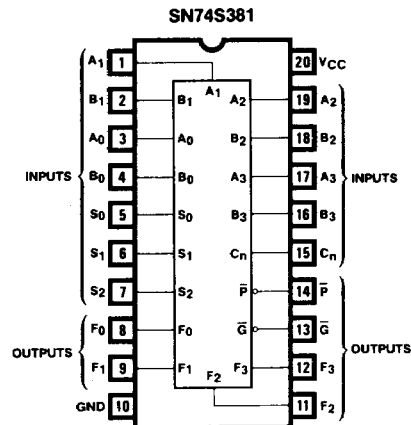

10

## Logic Symbol

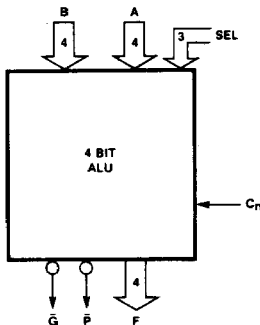

## Function Table

SELECTION			ARITHMETIC/LOGIC OPERATION
S2	S1	S0	
L	L	L	Clear †
L	L	H	B minus A
L	H	L	A minus B
L	H	H	A plus B
H	L	L	A ⊕ B
H	L	H	A + B
H	H	L	AB
H	H	H	Preset ††

† Force all F outputs to be Lows.  
 †† Force all F outputs to be Highs.

Logic Diagram

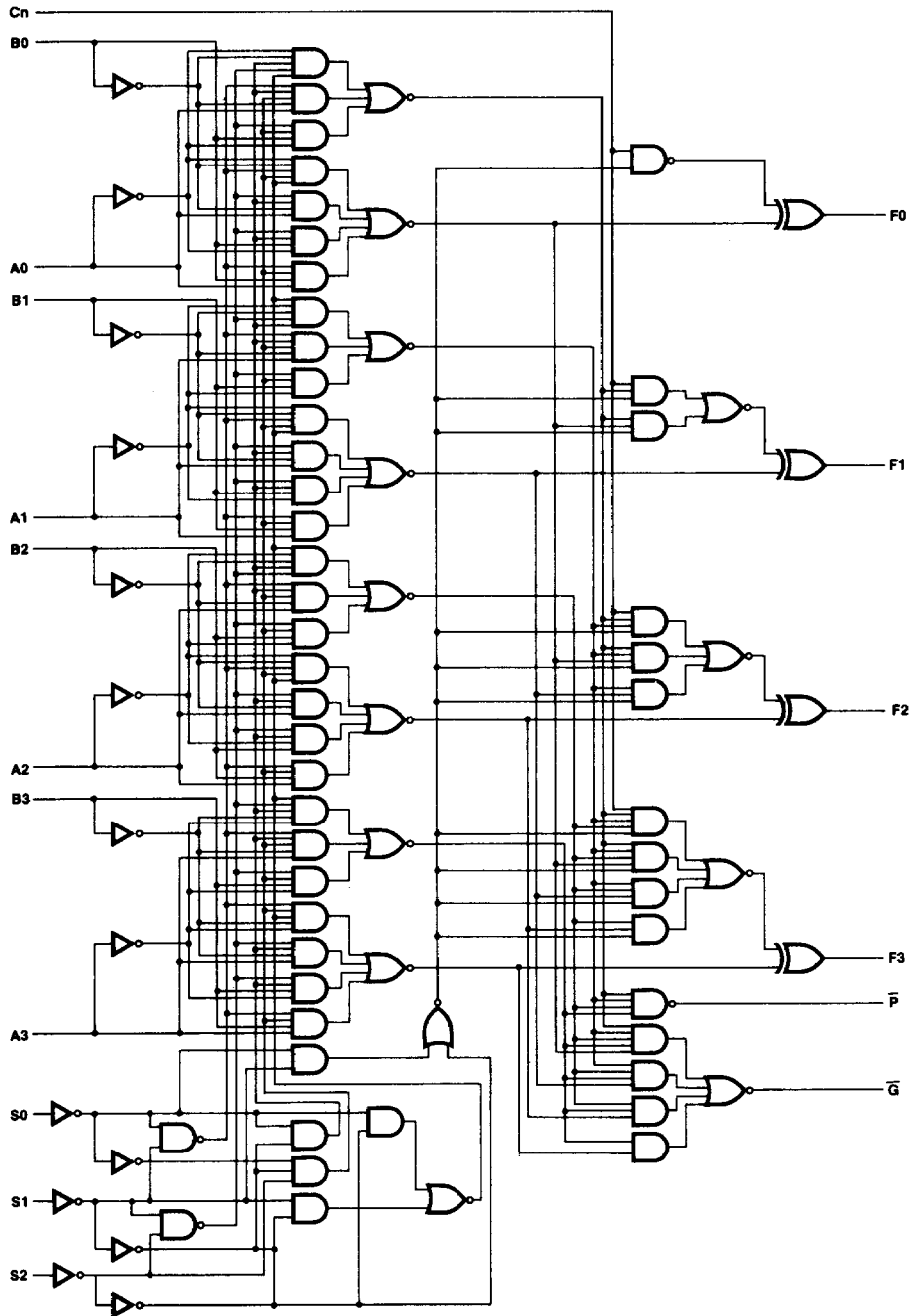

# SN74S381

## Function Table

FUNCTION	INPUTS												OUTPUTS									
	S2	S1	S0	Cn	A3	A2	A1	A0	B3	B2	B1	B0	F3	F2	F1	F0	$\overline{G}$	$\overline{P}$				
Clear	0	0	0	X	X	X	X	X	X	X	X	X	0	0	0	0	0	0				
B minus A (Inverse Subtraction)	0	0	1	0	0	0	0	0	0	0	0	0	1	1	1	1	1	0				
				0	0	0	0	0	1	1	1	1	1	1	1	1	0	0	0			
				0	1	1	1	0	0	0	0	0	0	0	0	0	0	0	0	1	1	
				0	1	1	1	1	1	1	1	1	1	1	1	1	1	1	1	1	0	0
				1	0	0	0	0	0	0	0	0	0	0	0	0	0	0	0	0	1	0
				1	0	0	0	0	1	1	1	1	1	1	1	1	1	1	1	1	0	0
				1	1	1	1	1	0	0	0	0	0	0	0	0	0	0	0	1	1	1
				1	1	1	1	1	1	1	1	1	1	1	1	1	0	0	0	0	1	0
A minus B (Subtract)	0	1	0	0	0	0	0	0	0	0	0	0	1	1	1	1	0	0				
				0	0	0	0	0	1	1	1	1	1	0	0	0	0	0	0	0		
				0	1	1	1	0	0	0	0	0	0	0	0	1	1	1	0	0	0	
				0	1	1	1	1	1	1	1	1	1	1	1	1	1	1	1	1	0	0
				1	0	0	0	0	0	0	0	0	0	0	0	0	0	0	0	0	1	0
				1	0	0	0	0	1	1	1	1	1	1	1	0	0	0	1	1	1	1
				1	1	1	1	0	0	0	0	0	0	0	0	1	1	1	1	0	0	0
				1	1	1	1	1	1	1	1	1	1	1	1	0	0	0	0	0	1	0
A plus B (Add)	0	1	1	0	0	0	0	0	0	0	0	0	0	0	0	0	0	1	1			
				0	0	0	0	0	1	1	1	1	1	1	1	1	1	1	1	0		
				0	1	1	1	0	0	0	0	0	0	0	0	1	1	1	1	1	0	
				0	1	1	1	1	1	1	1	1	1	1	1	1	1	1	0	0	0	0
				1	0	0	0	0	0	0	0	0	0	0	0	0	0	0	1	1	1	1
				1	0	0	0	0	1	1	1	1	1	1	1	0	0	0	0	1	0	0
				1	1	1	1	1	0	0	0	0	0	0	0	0	0	0	0	1	0	0
				1	1	1	1	1	1	1	1	1	1	1	1	1	1	1	1	0	0	0

10

## Function Table

FUNCTION	INPUTS												OUTPUTS			
	S2	S1	S0	Cn	A3	A2	A1	A0	B3	B2	B1	B0	F3	F2	F1	F0
$A \oplus B$ (OR)	1	0	0	X	0	0	0	0	0	0	0	0	0	0	0	0
				X	0	0	0	0	1	1	1	1	1	1	1	
				X	1	1	1	1	0	0	0	0	0	0	0	0
				X	1	1	1	1	1	1	1	1	1	1	1	0
$A \oplus B$ (XOR)	1	0	1	X	0	0	0	0	0	0	0	0	0	0	0	
				X	0	0	0	0	1	1	1	1	1	1	1	
				X	1	1	1	1	0	0	0	0	0	0	0	0
				X	1	1	1	1	1	1	1	1	1	1	1	1
$A \cdot B$ (AND)	1	1	0	X	0	0	0	0	0	0	0	0	0	0		
				X	0	0	0	0	1	1	1	1	0	0		
				X	1	1	1	1	0	0	0	0	0	0		
				X	1	1	1	1	1	1	1	1	1	1		
Preset	1	1	1	X	0	0	0	0	0	0	0	0	0			
				X	0	0	0	0	1	1	1	1	1			
				X	1	1	1	1	0	0	0	0	0			
				X	1	1	1	1	1	1	1	1	1			

1 = HIGH voltage level  
 0 = LOW voltage level  
 X = Don't care

# SN74S381

## Absolute Maximum Ratings

Supply voltage $V_{CC}$ .....	7 V
Input voltage .....	5.5 V
Storage temperature range .....	-65° to +150° C

## Operating Conditions

SYMBOL	PARAMETER	COMMERCIAL			UNIT
		MIN	TYP	MAX	
$V_{CC}$	Supply voltage	4.75	5	5.25	V
$T_A$	Operating free-air temperature	0		75	°C

## Electrical Characteristics Over Operating Conditions

SYMBOL	PARAMETER	TEST CONDITIONS		COMMERCIAL			UNIT
				MIN	TYP	MAX	
$V_{IL}$	Low-level input voltage					0.8	V
$V_{IH}$	High-level input voltage			2			V
$V_{IC}$	Input clamp voltage	$V_{CC} = \text{MIN}$	$I_I = -18 \text{ mA}$			-1.2	V
$I_{IL}$	Low-level input current	$V_{CC} = \text{MAX}$	$V_I = 0.5 \text{ V}$	Any S input		-2	mA
				Cn		-8	
				All others		-6	
$I_{IH}$	High-level input current	$V_{CC} = \text{MAX}$	$V_I = 2.7 \text{ V}$	Any S input		50	$\mu\text{A}$
				Cn		250	
				All others		200	
$I_I$	Maximum input current	$V_{CC} = \text{MAX}$	$V_I = 5.5 \text{ V}$			1	mA
$V_{OL}$	Low-Level output voltage	$V_{CC} = \text{MIN}$ $V_{IL} = 0.8 \text{ V}$	$V_{IH} = 2 \text{ V}$ $I_{OL} = 20 \text{ mA}$			0.5	V
$V_{OH}$	High-level output voltage	$V_{CC} = \text{MIN}$ $V_{IL} = 0.8 \text{ V}$	$V_{IH} = 2 \text{ V}$ $I_{OH} = -1 \text{ mA}$	2.7	3.4		V
$I_{OS}$	Output short-circuit current*	$V_{CC} = \text{MAX}$		-40		-100	mA
$I_{CC}$	Supply current	$V_{CC} = \text{MAX}$		105		160	mA

\* Not more than one output should be shorted at a time and duration of the short circuit should not exceed one second.

# SN74S381

## Switching Characteristics $V_{CC} = 5V, T_A = 25^\circ C$

SYMBOL	PARAMETER	TEST CONDITIONS (See Interface Test Load/Waveforms)	FROM (INPUT)	TO (OUTPUT)	74S381		UNIT
					TYP	MAX	
$t_p$	Propagation delay time	$C_L = 15\text{ pF} \quad R_L = 280\Omega$	C	Any F	10	17	ns
$t_p$	Propagation delay time		Any A or B	$\overline{G}$	12	20	ns
$t_p$	Propagation delay time		Any A or B	$\overline{P}$	11	18	ns
$t_{PLH}$	Propagation delay, low-to-high		Any A or B	Any F	18	27	ns
$t_{PHL}$	Propagation delay, high-to-low		Any A or B	Any F	16	25	ns
$t_p$	Propagation delay time		Any S	Any F, $\overline{G}, \overline{P}$	18	30	ns

### Test Load

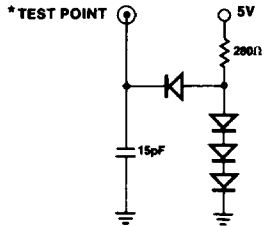

\* The "TEST POINT" is driven by the output under test, and observed by instrumentation.

10

### 16-BIT ALU (USING 74S381)

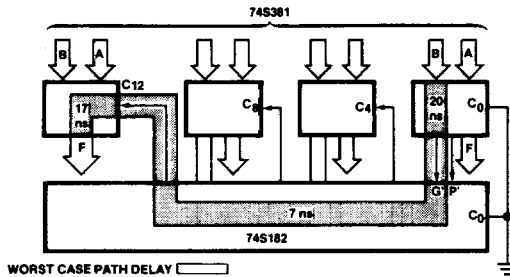

### MAXIMUM DELAY OF ADDITION/SUBTRACTION.

	74S381 + 74S182
1-4 bits	27ns
5-16 bits	44ns
17-64 bits	64ns