

Subminiature rectangular multicontact connectors MM series

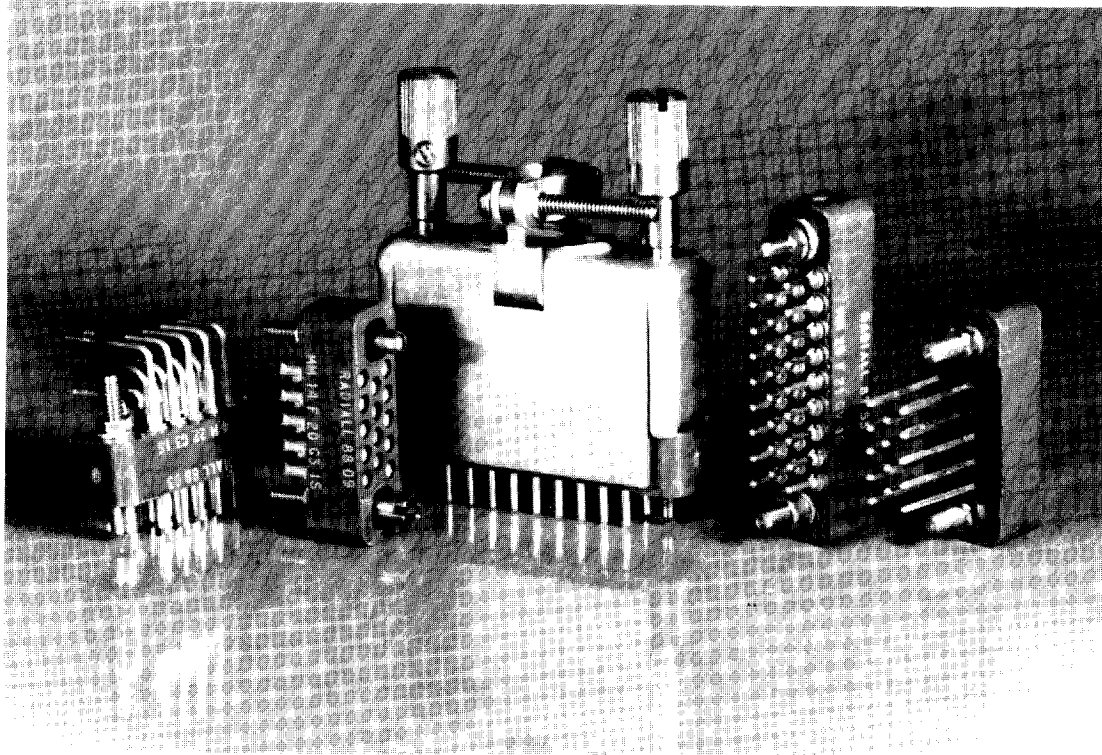

This series consists of six sizes of connector with contact arrangements of 7, 14, 20, 26, 34 and 50 size 22 contacts (.030 (0.762) dia.).

The **MM series** offers four types of termination :

- solder pot for wire (AWG 22 max)
- straight solder pin for PCB
- right angle solder pin for PCB
- wire wrap.

These connectors are fitted with rack guides or fixed or rotating jackscrews at each end. A protective covering for wire terminations can be installed on the connector.

CHARACTERISTICS

ELECTRICAL

Conforming to MIL-C-28748 performance requirements and UTE-C-93426 HE611 standard

- *Current rating* : 5 A
- *Test voltage at sea level* : 1000 Vrms / 50 Hz
- *Operating voltage (sea level)* : 350 Vrms / 50 Hz
- *Operating voltage (70,000 feet)* : 90 Vrms / 50 Hz
- *Insulation resistance* : > 5000 MΩ
- *Contact resistance* : < 5 mΩ

MECHANICAL

Conforming to MIL-C-28748 performance requirements and UTE-C-93426 HE611 standard

- *Temperature range* : -55°C +125°C
- *Durability* : 500 mating cycles
- *Shock* : 100 g/6 ms
- *Vibration* : 20 g / 10-2000 Hz
- *Humidity* : 56 days
- *Contact insertion force* : 3 N

MATERIALS

<i>Insulator</i> :	<i>glass filled diallylphthalate conforming to MIL-M-14SDG-F</i>
<i>Pin contact</i> :	<i>copper alloy, plating : gold over nickel</i>
<i>Socket contact</i> :	<i>copper alloy, plating : gold over nickel</i>
<i>Guides and jackscrews</i> :	<i>stainless steel</i>
<i>Hoods</i> :	<i>Yellow anodized aluminum alloy</i>

CONNECTOR MATED PAIR WEIGHT (g)

Contact arrangement	07	14	20	26	34	50
without guides	2.8	5	6.6	8.1	12.1	15
with rack guides	4.7	7	8.4	10	13	17.1
with hoods and guides or jackscrews	12	15.5	17	19.4	23.2	32.8

MM 34 M 20 VL IS

SERIES

Contact arrangement (see page 18)

07 - 14 - 20 - 26 - 34 - 50

Contact type

M : pin
F : socket

Termination style (see page 19)

20 : solder pot
21 : straight solder pin for PCB
22 : Right angle solder pin for PCB
23 : wrapping contact 1 wrap
24 : wrapping contact 2 wrap
25 : wrapping contact 3 wrap

Guides and jackscrews (see page 22)

00 : without guides and jackscrews (1)
G3 : rack guides (2)
GV : fixed jackscrews (2)
VR : short rotating jackscrews
VL : long rotating jackscrews (3)

Thread, guides or jackscrews

00 : without guides and jackscrews
IS : ISO (M2 x 0.4)
NC : 2-56 UNC

(1) connectors to be used with hood HC (see page 24) and rotating jackscrews.

(2) connectors to be used with hood HA (see page 24).

(3) VL jackscrew assembly is not available for termination style type 22.

CONNECTOR IDENTIFICATION

The part number is printed on the insulator side.

Part number for hoods page 24.

MALE CONNECTOR – WIRING SIDE

07

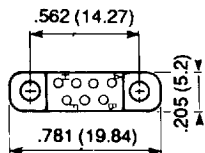

14

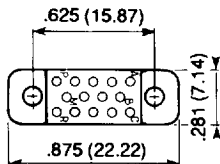

20

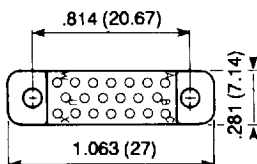

26

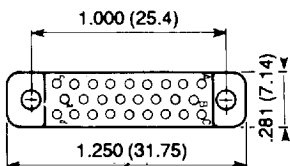

34

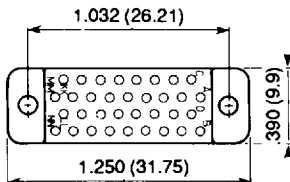

50

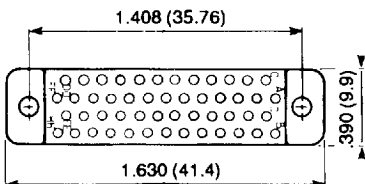

MATING DIMENSIONS

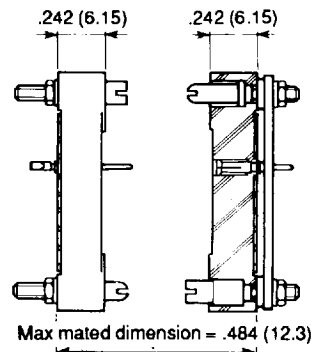

TYPE 20

Solder pot

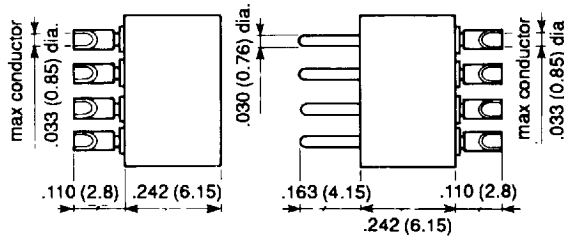

TYPE 21

Straight solder pin for PCB

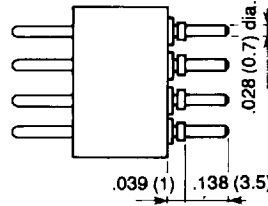

TYPE 22

Right angle solder pin for PCB

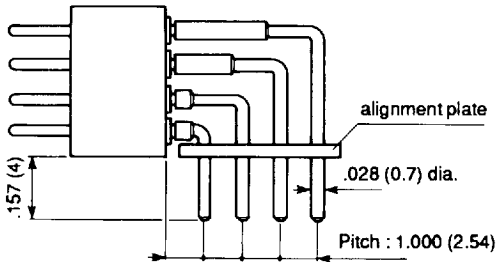

TYPE 23 – 24 – 25

- 23 : wire wrap termination (1 level)
- 24 : wire wrap termination (2 level)
- 25 : wire wrap termination (3 level)

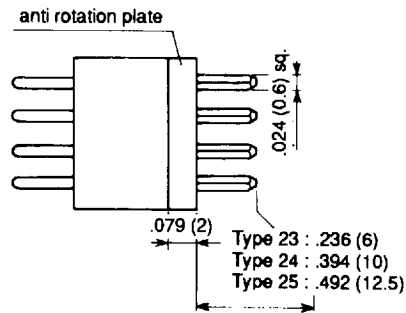

For termination style type 21, the connectors are supplied with insulating washers which act as spacers between the insulator and the PCB.

TYPE 21 TERMINATION STYLE – Connector with socket contacts

PCB component side view

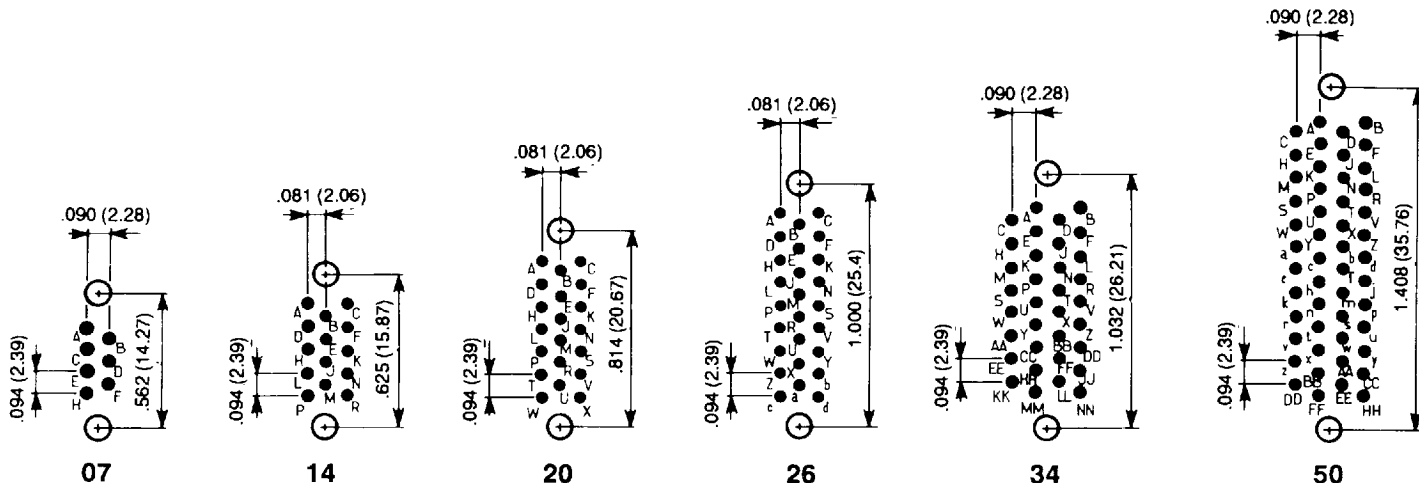

TYPE 21 TERMINATION STYLE – Connector with pin contacts

PCB component side view

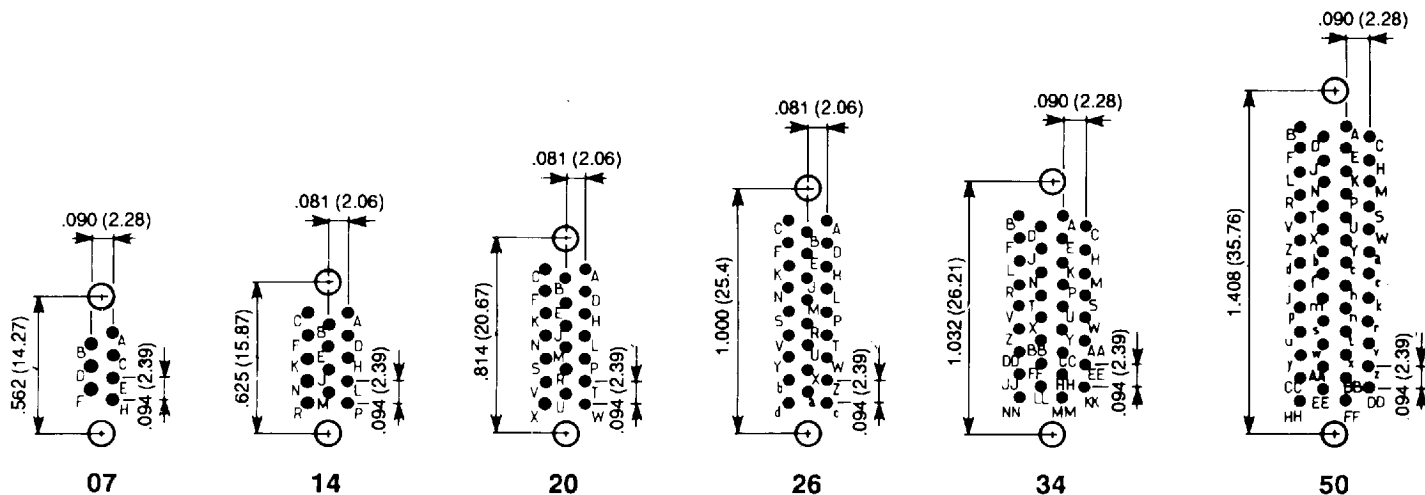

- Printed circuit drilling $.031 \pm .002$ (0.8 ± 0.05)
- Drilling to fix the connector. Required for guides G3 and GV fixing only :
 - .087 (2.2) dia. for ISO guides
 - .094 (2.4) dia. for UNC guides

TYPE 22 TERMINATION STYLE – Connector with socket contacts

PCB component side view

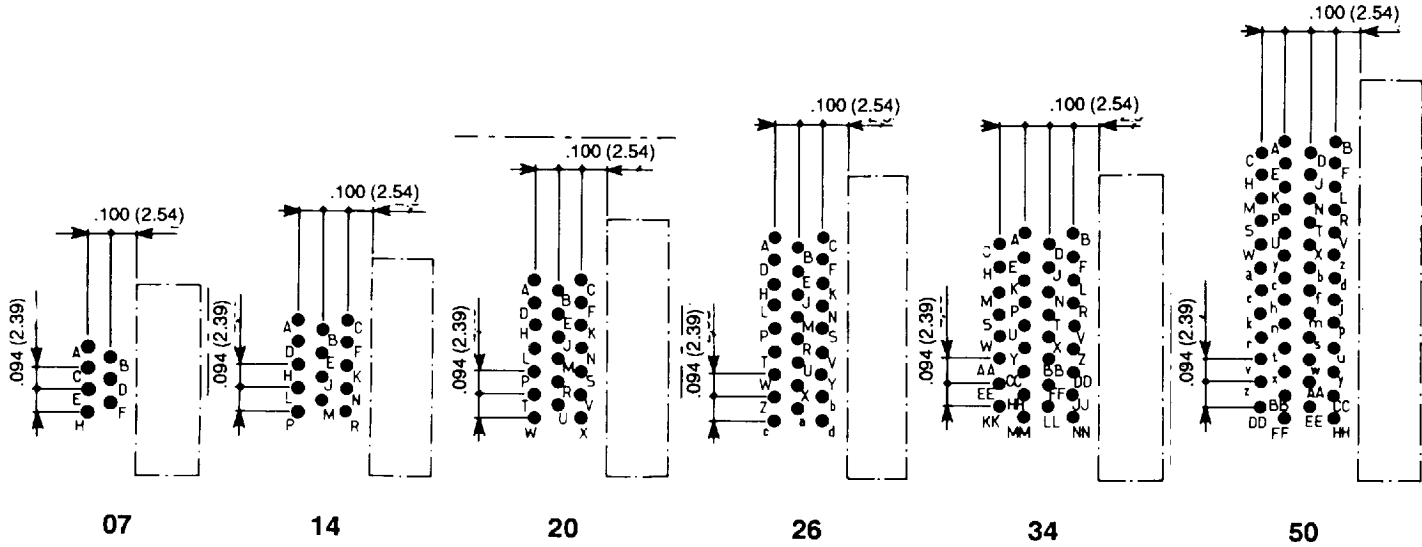

TYPE 22 TERMINATION STYLE – Connector with pin contacts

PCB component side view

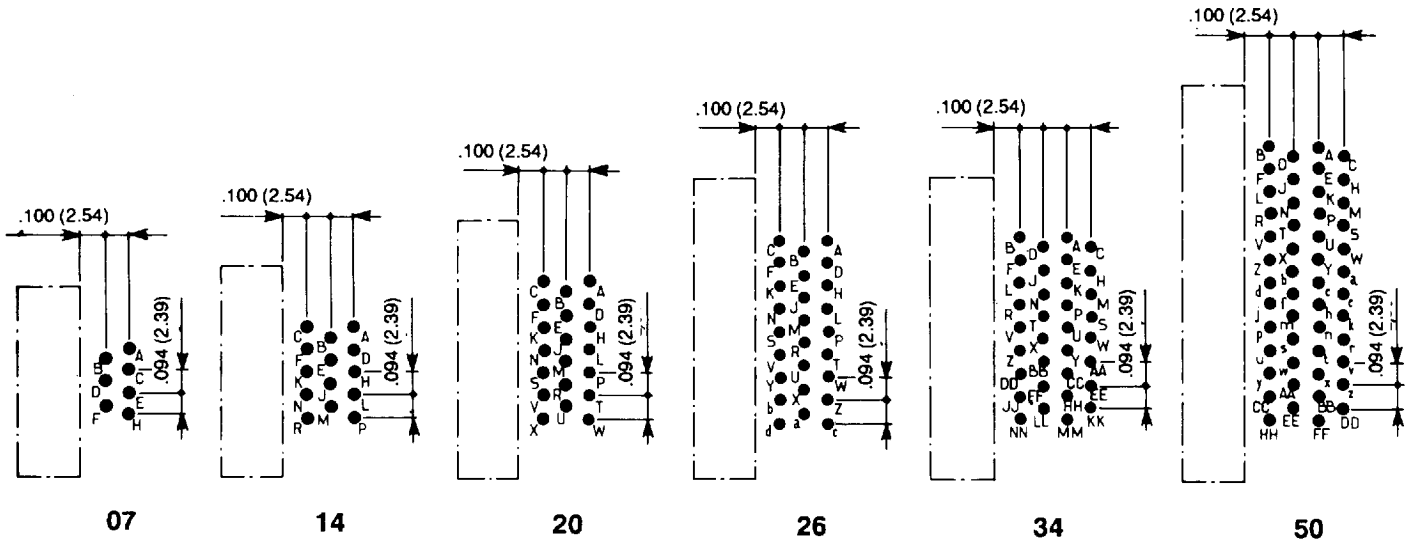

- Printed circuit drilling $.031 \pm .002$ (0.8 ± 0.05)

Stainless steel guides and jackscrews are supplied with either ISO (M2 x 0.4) or UNC (2-56 UNC) threads. The guides type (G3 – GV – VL – VR) and the jackscrews (ISO or UNC) required are to be defined in the part number (see page 17).

The standard configuration of guides and jackscrews is :

- Male guide (or jackscrew) at the end nearest contact A of the female connector.
- Female guide (or jackscrew) at the end nearest contact A of the male connector.

RACK GUIDES TYPE G3

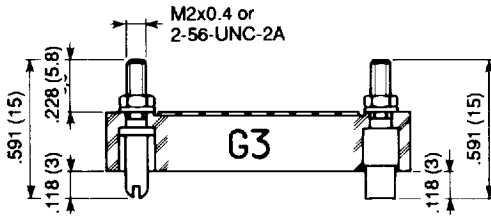

FIXED JACKSCREWS TYPE GV

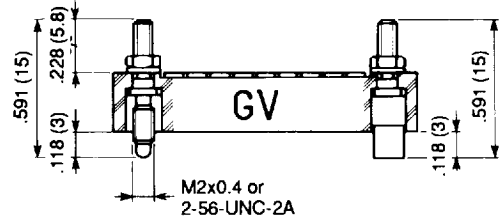

These guide and jackscrews can be used with hood HA

LONG AND SHORT ROTATING JACKSCREWS TYPE VL-VR

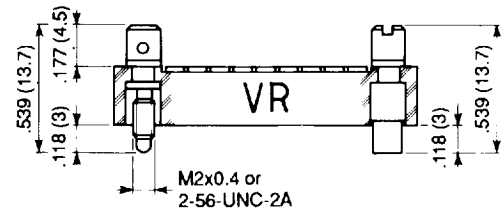
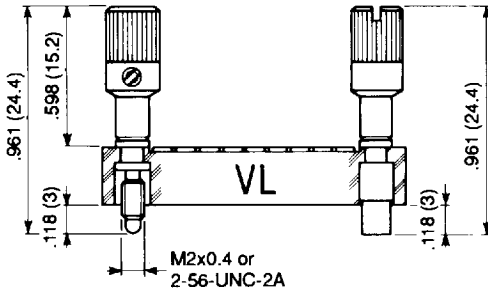

Mating force : 2cm/daN
Cannot be used with any hoods

Mating force : 2cm/daN
Not available for termination style type 22
.Cannot be use with any hoods

DIMENSIONS

Contacts arrangements	A	B	C
07	.468 (11.9)	.562 (14.27)	.228 (5.8)
14	.531 (13.5)	.625 (15.87)	.299 (7.6)
20	.720 (18.3)	.814 (20.67)	.299 (7.6)
26	.905 (23)	1.000 (25.4)	.299 (7.6)
34	.940 (23.9)	1.031 (26.2)	.409 (10.4)
50	1.315 (33.4)	1.408 (35.76)	.409 (10.4)

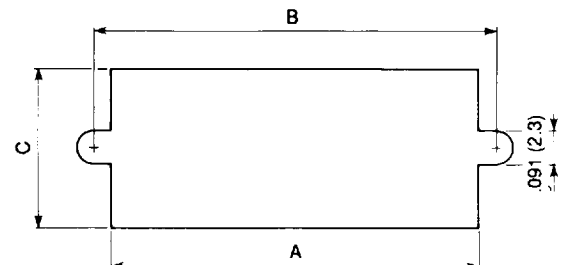

USE WITH HOOD (Termination style type 20 only)

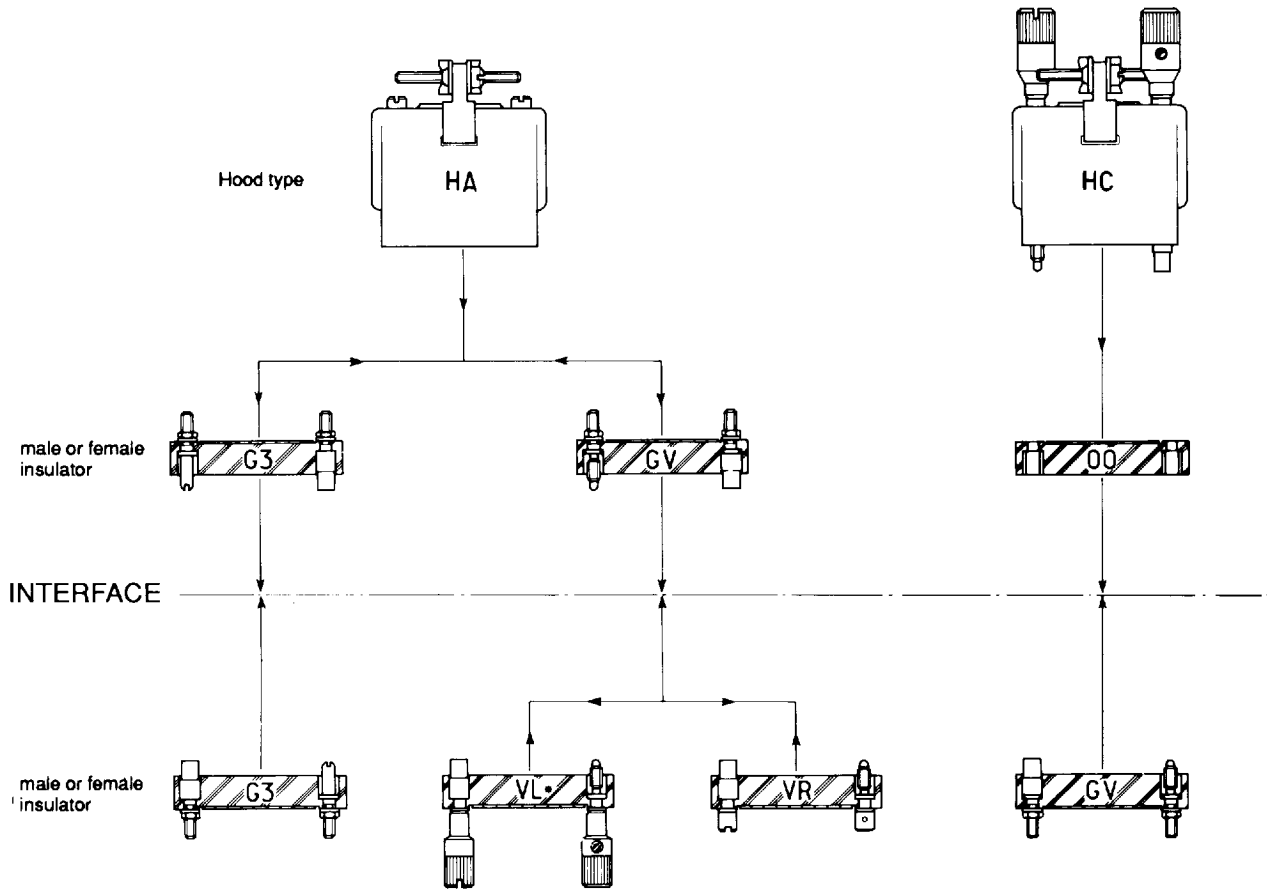

USE WITHOUT HOOD (All termination style type)

M

Hood type availability

THREAD		HOOD		THREAD	
NC (2-56 UNC)	ISO (M2 x 0.4)	Top entry		ISO (M2 x 0.4)	NC (2-56 UNC)
07	07			07	07
14	14			14	14
20	20			20	20
26	26			26	26
34	34			34	34
50	50			50	50

Fixing of hoods only suitable for insulator with termination style type 20 (solder pot).

TYPE HA

Hoods supplied with two internal threaded posts which are screwed into the guides G3 or jackscrews GV.

TYPE HC

Hoods supplied with two long rotating jackscrews. These hoods are mounted on connectors without guides or jackscrews (code 00).

PART NUMBERS

Contacts arrangements	Type HA		Type HC	
	with threads M2 x 0.4	with threads 2-56 UNC	with screws M2 x 0.4	with screws 2-56 UNC
07	MM 07 HA IS	MM 07 HA NC	MM 07 HC IS	MM 07 HC NC
14	MM 14 HA IS	MM 14 HA NC	MM 14 HC IS	MM 14 HC NC
20	MM 20 HA IS	MM 20 HA NC	MM 20 HC IS	MM 20 HC NC
26	MM 26 HA IS	MM 26 HA NC	MM 26 HC IS	MM 26 HC NC
34	MM 34 HA IS	MM 34 HA NC	MM 34 HC IS	MM 34 HC NC
50	MM 50 HA IS	MM 50 HA NC	MM 50 HC IS	MM 50 HC NC

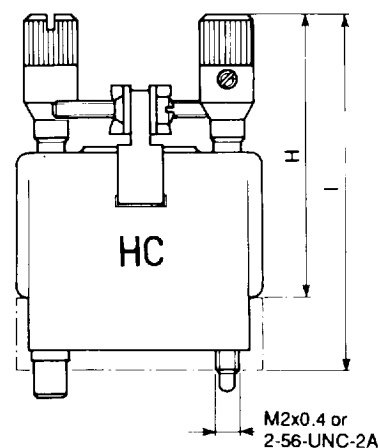
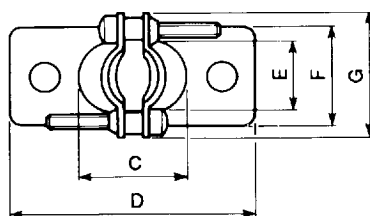
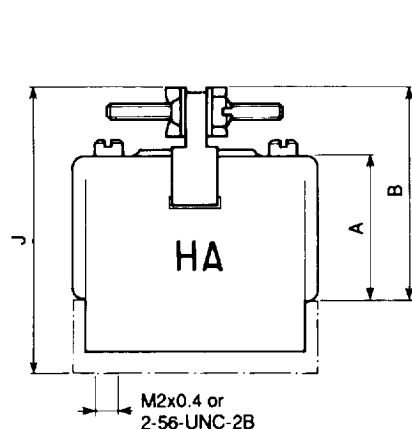

Mating force : 1.5cm/daN

DIMENSIONS

Contacts arrangements	A	B	C	D	E	F	G	H	I	J
07	.626 (15.9)	.911 (23.15)	.216 (5.5)	.779 (19.8)	.157 (4)	.268 (6.8)	.531 (13.5)	1.256 (31.9)	1.504 (38.2)	1.157 (29.4)
14	.626 (15.9)	.911 (23.15)	.394 (10)	.874 (22.2)	.236 (6)	.346 (8.8)	.531 (13.5)	1.256 (31.9)	1.504 (38.2)	1.157 (29.4)
20	.626 (15.9)	.911 (23.15)	.551 (14)	1.063 (27)	.236 (6)	.346 (8.8)	.531 (13.5)	1.256 (31.9)	1.504 (38.2)	1.157 (29.4)
26	.626 (15.9)	.911 (23.15)	.551 (14)	1.252 (31.8)	.236 (6)	.346 (8.8)	.531 (13.5)	1.256 (31.9)	1.504 (38.2)	1.157 (29.4)
34	.626 (15.9)	.911 (23.15)	.748 (19)	1.252 (31.8)	.374 (9.5)	.464 (11.8)	.618 (15.7)	1.256 (31.9)	1.504 (38.2)	1.197 (30.4)
50	1.201 (30.5)	1.516 (38.5)	1.169 (29.7)	1.630 (41.4)	.374 (9.5)	.464 (11.8)	.618 (15.7)	1.835 (46.6)	2.083 (52.9)	1.764 (44.8)

Fixing of hoods only suitable for insulator with termination style type 20 (solder pot).