

Avantek Products

# Thin-Film Cascadable Amplifier 5 to 1000 MHz

## Technical Data

### UTO/UTC 1054 Series

#### Features

- **Frequency Range: 5 to 1000MHz**
- **High Gain: 24 dB (Typ)**
- **Low Noise Figure: 3.5 dB (Typ)**
- **5-Volt Supply**
- **High Dynamic Range**
- **Temperature Compensated**

#### Applications

- **IF/RF Amplification**
- **5 Volt Systems**

#### Description

The 1054 Series is a 5-volt two-stage, thin-film RF amplifier using active bias and resistive feedback for temperature compensation and increased immunity to bias voltage variations. Low VSWR is maintained by inductive tuning while the RF is coupled through the amplifier by internal blocking capacitors. The 1054 Series amplifiers are available in either the TO-8 hermetic case or connected TC-1 package.

#### Pin Configuration UTO—TO-8T

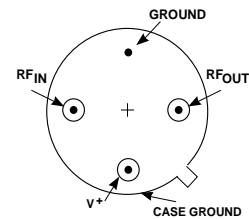

#### UTC—TC-1

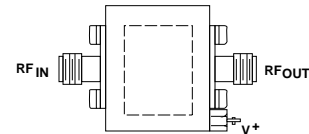

#### Schematic

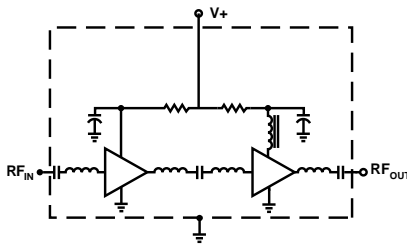

#### Maximum Ratings

Parameter	Maximum
DC Voltage	+10.0 Volts
Continuous RF Input Power	+13 dBm
Operating Case Temperature	-55 to +125°C
Storage Temperature	-62 to +150°C
"R" Series Burn-In Temperature	+125°C

#### Thermal Characteristics<sup>1</sup>

$\theta_{JC}$	105/75°C/W <sup>2</sup>
Active Transistor Power Dissipation	48/109 mW <sup>2</sup>
Junction Temperature Above Case Temperature	5/8°C <sup>2</sup>
MTBF (MIL-HDBK-217E, $A_{UF}$ @ 90°C)	575,700 Hrs.

Notes:

1. For further information, see Reliability Screening, Pub. 5963-3240E.
2. Values refer to first and second stages, respectively.

**Weight:** (typical) UTO—2.1 grams; UTC—21.5 grams

## Electrical Specifications

(Measured in 50  $\Omega$  system @ +5 VDC nominal unless otherwise noted)

Symbol	Characteristic	Typical $T_c = 25^\circ\text{C}$	Guaranteed Specifications		Unit
			$T_c = 0$ to $50^\circ\text{C}$	$T_c = -55$ to $+85^\circ\text{C}$	
BW	Frequency Range	5-1000	5-1000	5-1000	MHz
GP	Small Signal Gain (Min.)	24.0	23.5	23.0	dB
—	Gain Flatness (Max.)	$\pm 0.3$	$\pm 0.7$	$\pm 0.7$	dB
NF	Noise Figure (Max.)	3.5	4.0	4.5	dB
P <sub>1dB</sub>	Power Output @ +1 dB Comp. (Min.)	+10.5	+9.5	+9.0	dBm
—	Input VSWR (Max.)	<1.5:1	2.0:1	2.0:1	—
—	Output VSWR (Max.)	<1.5:1	2.0:1	2.0:1	—
IP <sub>3</sub>	Two Tone 3rd Order Intercept Point	+21.0	—	—	dBm
IP <sub>2</sub>	Two Tone 2nd Order Intercept Point	+38.0	—	—	dBm
HP <sub>2</sub>	One Tone 2nd Harmonic Intercept Point	+44.0	—	—	dBm
I <sub>D</sub>	DC Current	40	—	—	mA

## Typical Performance Over Temperature (@ +5 VDC unless otherwise noted)

Key: +25°C —  
+85°C - -  
-55°C —

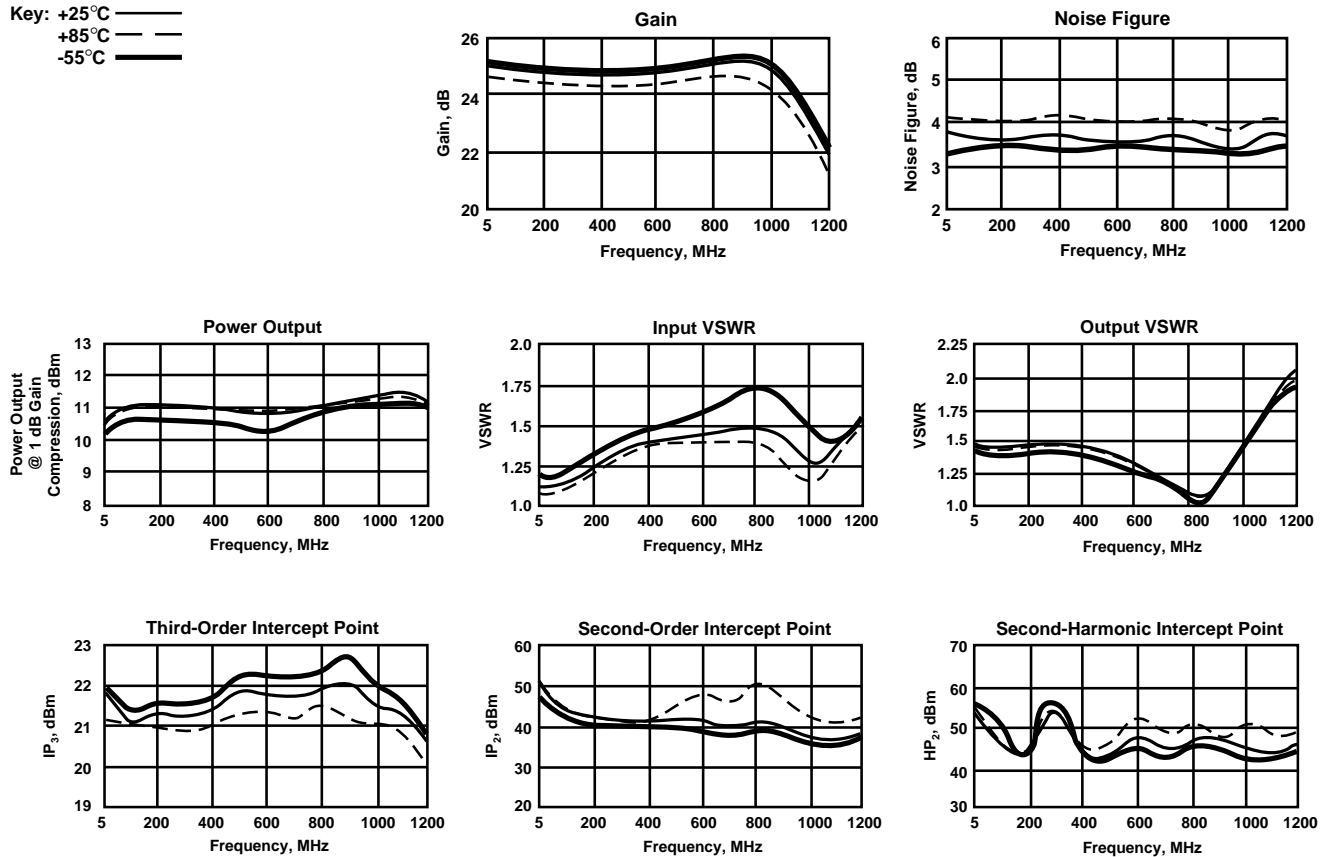

**Automatic Network Analyzer Measurements** (Typical production unit @ +25°C ambient)

**Numerical Readings**
**Bias = 5.00 Volts**

FREQ GHz	GPDEL ns	PHASE DEG	FREQ GHz	GPDEL ns	PHASE DEG
.050	.78	-2.18	.525	.73	2.76
.075	.78	-2.30	.550	.73	3.11
.100	.77	-2.37	.575	.73	3.46
.125	.77	-2.50	.600	.74	3.64
.150	.75	-2.40	.625	.75	3.79
.175	.74	-2.18	.650	.75	3.90
.200	.74	-1.91	.675	.76	3.91
.225	.74	-1.78	.700	.77	3.80
.250	.71	-1.31	.725	.79	3.56
.275	.72	-.90	.750	.80	3.20
.300	.73	-.65	.775	.82	2.71
.325	.72	-.29	.800	.83	2.05
.350	.73	.05	.825	.85	1.25
.375	.72	.40	.850	.87	.25
.400	.71	.82	.825	.80	-.86
.425	.70	1.32	.900	.92	-2.29
.450	.73	1.66	.925	.93	-3.88
.475	.72	2.05	.950	.06	-5.59
.500	.72	2.43	.975	.08	-7.47
			1.000	.96	9.28

Linearization Range: .05 to 1.00 GHz

**S-Parameters**
**Bias = 5.00 Volts**

FREQUENCY MHz	S <sub>11</sub>		S <sub>21</sub>		S <sub>12</sub>		S <sub>22</sub>	
	Mag	Ang	dB	Ang	dB	Ang	Mag	Ang
.005	.07	-178.1	24.6	20.5	-34.0	21.1	.21	166.95
.010	.05	-179.7	24.6	7.8	-34.0	9.8	.19	172.71
.020	.04	-175.4	24.6	.1	-33.9	3.6	.18	174.29
.030	.04	-171.7	24.6	-4.4	-33.9	1.0	.18	174.63
.040	.04	-167.7	24.6	-7.9	-33.9	-.8	.18	174.60
.050	.04	-164.4	24.6	-11.1	-33.9	-2.4	.18	174.50
.100	.06	-152.2	24.6	-25.4	-34.0	-7.5	.18	173.04
.150	.07	-148.8	24.5	-38.7	-34.0	11.4	.18	171.17
.200	.09	-150.3	24.5	-51.8	-34.0	-15.4	.18	168.66
.250	.11	-154.5	24.4	-64.8	-34.1	-19.7	.18	166.00
.300	.13	-159.8	24.4	-77.7	-34.1	-23.3	.19	162.32
.350	.14	-165.6	24.4	-90.6	-34.2	-27.4	.19	157.86
.400	.16	-172.5	24.4	-103.5	-34.2	-31.0	.18	152.91
.450	.16	-179.3	24.4	-116.5	-34.3	-34.5	.18	147.27
.500	.17	171.3	24.4	-129.6	-34.4	-38.6	.17	141.05
.550	.17	162.0	24.5	-142.8	-34.3	-42.6	.15	134.50
.600	.18	151.4	24.5	-156.3	-34.4	-46.5	.14	127.59
.650	.18	139.9	24.6	-169.9	-34.4	-50.5	.12	121.05
.700	.19	127.6	24.6	176.1	-34.4	-54.6	.10	115.30
.750	.19	114.9	24.7	161.8	-34.4	-59.5	.08	111.99
.800	.19	101.4	24.8	146.9	-34.6	-64.1	.05	116.92
.850	.19	86.8	24.8	131.4	-34.6	-69.3	.03	152.00
.900	.17	69.5	24.8	115.2	-34.8	-74.2	.06	-158.75
.950	.15	47.1	24.7	98.1	-35.1	-79.1	.11	-149.77
1.000	.12	15.1	24.4	80.4	-35.5	-83.9	.17	-153.20
1.100	.14	-63.7	23.3	44.8	-36.8	-91.3	.28	-168.85
1.200	.22	-105.7	21.5	11.6	-37.6	-91.7	.33	173.92
1.250	.24	-117.8	20.4	-3.5	-37.6	-89.5	.33	165.62
1.300	.25	-126.5	19.3	-17.9	-37.4	-89.8	.31	157.44
1.400	.23	-139.1	17.1	-44.8	-36.5	-92.0	.26	139.07
1.500	.17	-144.5	14.9	-70.1	-35.5	-102.1	.19	115.14
2.000	.26	-97.6	4.2	-175.1	-34.8	-159.0	.11	-83.31
3.000	.76	171.8	-16.4	45.9	-36.5	105.7	.41	136.14

## Product Options

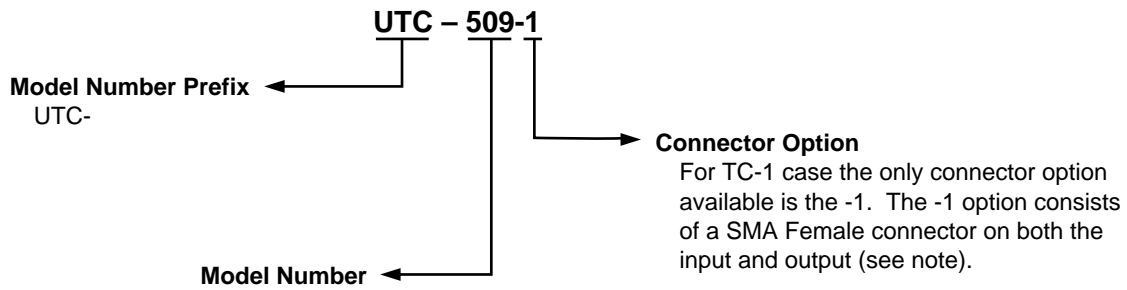
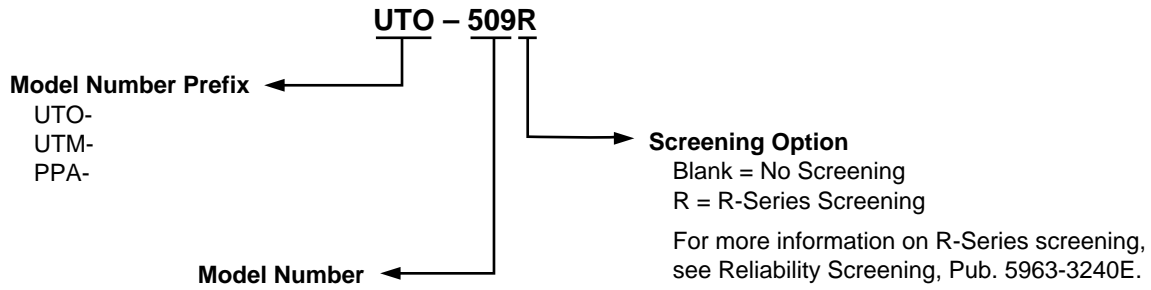

Note: R-Series screening is not available in the TC-1 case as the case is non-hermetic.

**Case Drawings  
TO-8T**

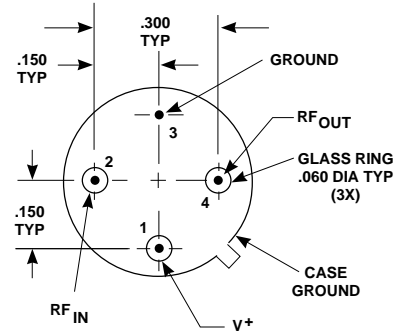
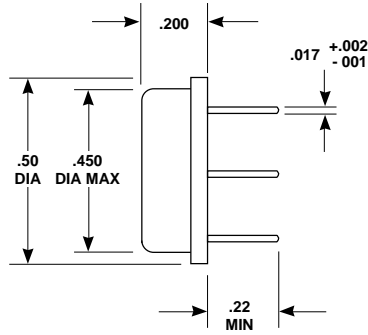
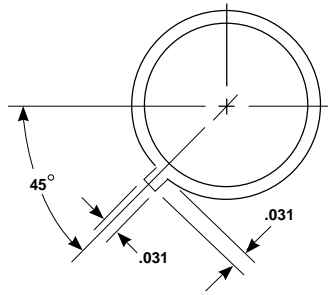

APPROXIMATE WEIGHT 2.1 GRAMS

- NOTES (UNLESS OTHERWISE SPECIFIED):  
 1. DIMENSIONS ARE SPECIFIED IN INCHES  
 2. TOLERANCES:   xx ± .02  
                       xxx ± .010

## Case Drawings TC-1

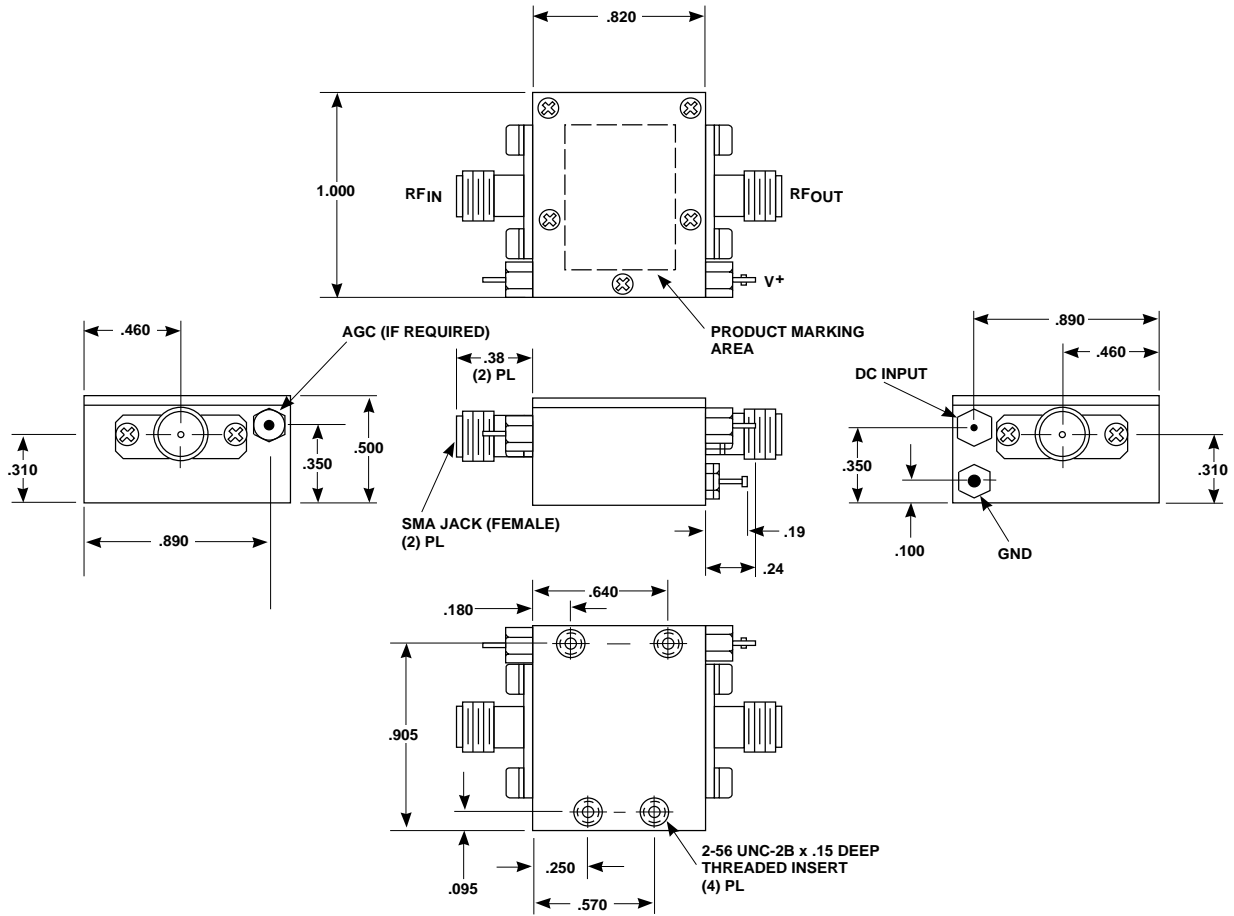

TYPICAL WEIGHT WITH CONNECTORS = 21.5 GRAMS

- NOTES: 1. THE TC-1 CASE IS A NON-HERMETIC CASE.  
2. THE ONLY CONNECTOR OPTION AVAILABLE FOR THE TC-1 CASE IS THE -1, SMA FEMALE CONNECTORS AT BOTH INPUT AND OUTPUT PORTS.

- NOTES (UNLESS OTHERWISE SPECIFIED):  
1. DIMENSIONS ARE SPECIFIED IN INCHES  
2. TOLERANCES: xx ± .02  
xxx ± .010

For more information:

United States\*

Europe\*

Far East/Australasia: (65) 290-6305

Canada: (416) 206-4725

Japan: (81 3) 3331-6111

\*Call your local HP sales office listed in your telephone directory. Ask for a Components representative.

Data Subject to Change  
Copyright © 1995 Hewlett-Packard Co.

Printed in U.S.A. 5963-2508E (10/94)