

Radiation Hardened Synchronous 4-Bit Up/Down Counter

September 1995

Features

- 3 Micron Radiation Hardened CMOS SOS
- Total Dose 200K RAD (Si)
- SEP Effective LET No Upsets: >100 MEV-cm²/mg
- Single Event Upset (SEU) Immunity < 2 x 10⁻⁹ Errors/Bit-Day (Typ)
- Dose Rate Survivability: >1 x 10¹² RAD (Si)/s
- Dose Rate Upset >10¹⁰ RAD (Si)/s 20ns Pulse
- Latch-Up Free Under Any Conditions
- Fanout (Over Temperature Range)
 - Standard Outputs - 10 LSTTL Loads
- Military Temperature Range: -55°C to +125°C
- Significant Power Reduction Compared to LSTTL ICs
- DC Operating Voltage Range: 4.5V to 5.5V
- LSTTL Input Compatibility
 - VIL = 0.8V Max
 - VIH = VCC/2 Min
- Input Current Levels I_i ≤ 5μA @ VOL, VOH

Description

The Harris HCTS190MS is an asynchronously presettable BCD Decade synchronous counter. Presetting the counter to the number on the preset data inputs (P0 - P3) is accomplished by a low on the parallel load input (\overline{PL}). Counting occurs when (\overline{PL}) is high, Count Enable (\overline{CE}) is low and the Up/Down ($\overline{U/D}$) input is either low for up-counting or high for down-counting. The counter is incremented or decremented synchronously with the low-to-high transition of the clock.

When an overflow or underflow of the counter occurs, the Terminal Count output (TC), which is low during counting, goes high and remains high for one clock cycle. This output can be used for look-ahead carry in high speed cascading. The TC output also initiates the Ripple Clock output (RC) which, normally high, goes low and remains low for the low-level portion of the clock pulse. These counter can be cascaded using the Ripple Carry output.

If the decade counter is preset to an illegal state or assumes an illegal state when power is applied, it will return to the normal sequence in one or two counts

The HCTS190MS utilizes advanced CMOS/SOS technology to achieve high-speed operation. This device is a member of radiation hardened, high-speed, CMOS/SOS Logic Family.

The HCTS190MS is supplied in a 16 lead Ceramic flatpack (K suffix) or a SBDIP Package (D suffix).

Ordering Information

PART NUMBER	TEMPERATURE RANGE	SCREENING LEVEL	PACKAGE
HCTS190DMSR	-55°C to +125°C	Harris Class S Equivalent	16 Lead SBDIP
HCTS190KMSR	-55°C to +125°C	Harris Class S Equivalent	16 Lead Ceramic Flatpack
HCTS190D/Sample	+25°C	Sample	16 Lead SBDIP
HCTS190K/Sample	+25°C	Sample	16 Lead Ceramic Flatpack
HCTS190HMSR	+25°C	Die	Die

Pinouts

16 LEAD CERAMIC DUAL-IN-LINE METAL SEAL PACKAGE (SBDIP) MIL-STD-1835 CDIP2-T16, LEAD FINISH C

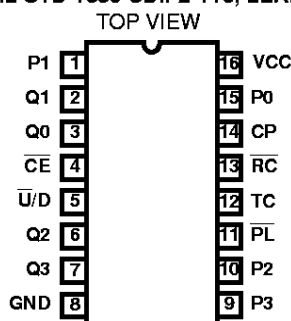

16 LEAD CERAMIC METAL SEAL FLATPACK PACKAGE (FLATPACK) MIL-STD-1835 CDFP4-F16, LEAD FINISH C

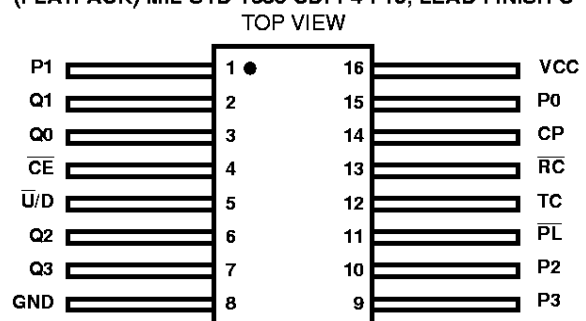

HCTS190MS

Functional Diagram

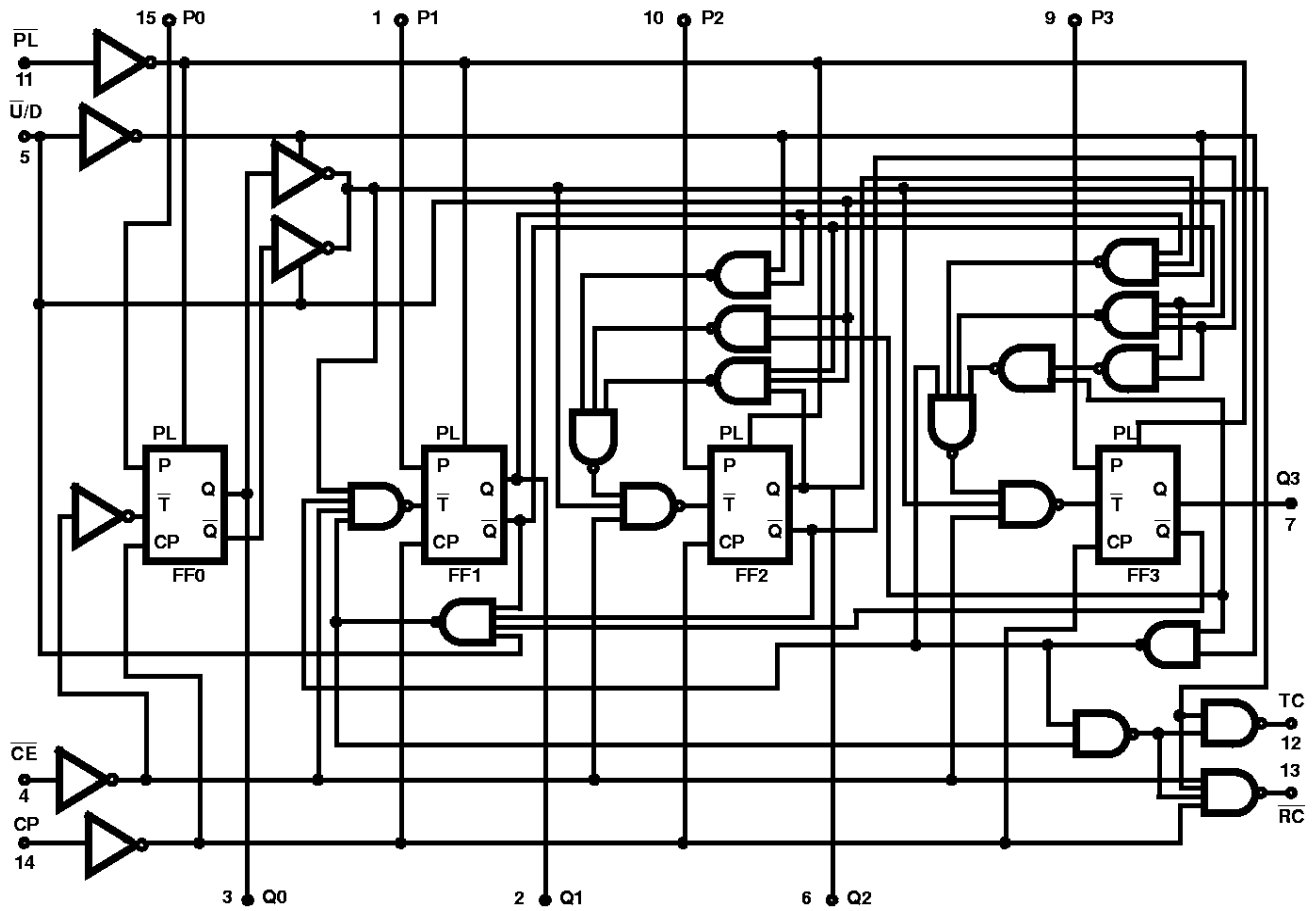

TRUTH TABLE

FUNCTION	\overline{P}_i	\overline{CE}	$\overline{U/D}$	CP
Count Up	H	L	L	/
Count Down	H	L	H	/
Asynchronous Preset	L	X	X	X
No Change	H	H	X	X

H = High Level

L = Low Level

X = Immaterial

/ = Transition from low to high

NOTE: $\overline{U/D}$ or \overline{CE} should be changed only when clock is high.

Specifications HCTS190MS

Absolute Maximum Ratings

Supply Voltage (VCC)	-0.5V to +7.0V
Input Voltage Range, All Inputs	-0.5V to VCC +0.5V
DC Input Current, Any One Input	±10mA
DC Drain Current, Any One Output (All Voltage Reference to the VSS Terminal)	±25mA
Storage Temperature Range (TSTG)	-65°C to +150°C
Lead Temperature (Soldering 10sec)	+265°C
Junction Temperature (TJ)	+175°C
ESD Classification	Class 1

Reliability Information

Thermal Resistance	θ_{JA}	θ_{JC}
SBDIP Package	73°C/W	24°C/W
Ceramic Flatpack Package	114°C/W	29°C/W
Maximum Package Power Dissipation at +125°C Ambient		
SBDIP Package		0.68W
Ceramic Flatpack Package		0.44W
If device power exceeds package dissipation capability, provide heat sinking or derate linearly at the following rate:		
SBDIP Package		13.7mW/°C
Ceramic Flatpack Package		8.8mW/°C

CAUTION: As with all semiconductors, stress listed under "Absolute Maximum Ratings" may be applied to devices (one at a time) without resulting in permanent damage. This is a stress rating only. Exposure to absolute maximum rating conditions for extended periods may affect device reliability. The conditions listed under "Electrical Performance Characteristics" are the only conditions recommended for satisfactory device operation..

Operating Conditions

Supply Voltage(VCC)	+4.5V to +5.5V	Input Low Voltage (VIL)	0.0V to 0.8V
Input Rise and Fall Times @ 4.5 VCC (TR, TF)	.500ns Max	Input High Voltage (VIH)	VCC/2 to VCC
Operating Temperature Range (TA)	-55°C to +125°C		

TABLE 1. DC ELECTRICAL PERFORMANCE CHARACTERISTICS

PARAMETER	SYMBOL	(NOTE 1) CONDITIONS	GROUP A SUB- GROUPS	TEMPERATURE	LIMITS		UNITS
					MIN	MAX	
Quiescent Current	ICC	VCC = 5.5V, VIN = VCC or GND	1	+25°C	-	40	µA
			2, 3	+125°C, -55°C	-	750	µA
Output Current (Sink)	IOL	VCC = 4.5V, VIH = 4.5V, VOUT = 0.4V, VIL = 0V	1	+25°C	4.8	-	mA
			2, 3	+125°C, -55°C	4.0	-	mA
Output Current (Source)	IOH	VCC = 4.5V, VIH = 4.5V, VOUT = VCC -0.4V, VIL = 0V	1	+25°C	-4.8	-	mA
			2, 3	+125°C, -55°C	-4.0	-	mA
Output Voltage Low	VOL	VCC = 4.5V, VIH = 2.25V, IOL = 50µA, VIL = 0.8V	1, 2, 3	+25°C, +125°C, -55°C	-	0.1	V
		VCC = 5.5V, VIH = 2.75V, IOL = 50µA, VIL = 0.8V	1, 2, 3	+25°C, +125°C, -55°C	-	0.1	V
Output Voltage High	VOH	VCC = 4.5V, VIH = 2.25V, IOL = -50µA, VIL = 0.8V	1, 2, 3	+25°C, +125°C, -55°C	VCC -0.1	-	V
		VCC = 5.5V, VIH = 2.75V, IOL = -50µA, VIL = 0.8V	1, 2, 3	+25°C, +125°C, -55°C	VCC -0.1	-	V
Input Leakage Current	IIN	VCC = 5.5V, VIN = VCC or GND	1	+25°C	-	±0.5	µA
			2, 3	+125°C, -55°C	-	±5.0	µA
Noise Immunity Functional Test	FN	VCC = 4.5V, VIH = 2.25V, VIL = 0.8V (Note 2)	7, 8A, 8B	+25°C, +125°C, -55°C	-	-	-

NOTES:

1. All voltages reference to device GND.
2. For functional tests $VO \geq 4.0V$ is recognized as a logic "1", and $VO \leq 0.5V$ is recognized as a logic "0".

Specifications HCTS190MS

TABLE 2. AC ELECTRICAL PERFORMANCE CHARACTERISTICS

PARAMETER	SYMBOL	(NOTES 1, 2) CONDITIONS	GROUP A SUB- GROUPS	TEMPERATURE	LIMITS		UNITS
					MIN	MAX	
PL to Qn	TPLH	VCC = 4.5V	9	+25°C	2	32	ns
			10, 11	+125°C, -55°C	2	37	ns
	TPHL	VCC = 4.5V	9	+25°C	2	38	ns
			10, 11	+125°C, -55°C	2	44	ns
Pn to Qn	TPLH	VCC = 4.5V	9	+25°C	2	24	ns
			10, 11	+125°C, -55°C	2	28	ns
	TPHL	VCC = 4.5V	9	+25°C	2	36	ns
			10, 11	+125°C, -55°C	2	41	ns
CP to Qn	TPLH	VCC = 4.5V	9	+25°C	2	24	ns
			10, 11	+125°C, -55°C	2	29	ns
	TPHL	VCC = 4.5V	9	+25°C	2	23	ns
			10, 11	+125°C, -55°C	2	27	ns
CP to RC	TPLH	VCC = 4.5V	9	+25°C	2	17	ns
			10, 11	+125°C, -55°C	2	19	ns
	TPHL	VCC = 4.5V	9	+25°C	2	26	ns
			10, 11	+125°C, -55°C	2	29	ns
CP to TC	TPLH	VCC = 4.5V	9	+25°C	2	33	ns
			10, 11	+125°C, -55°C	2	39	ns
	TPHL	VCC = 4.5V	9	+25°C	2	33	ns
			10, 11	+125°C, -55°C	2	39	ns
UD to RC	TPLH	VCC = 4.5V	9	+25°C	2	32	ns
			10, 11	+125°C, -55°C	2	36	ns
	TPHL	VCC = 4.5V	9	+25°C	2	34	ns
			10, 11	+125°C, -55°C	2	38	ns
UD to TC	TPLH	VCC = 4.5V	9	+25°C	2	29	ns
			10, 11	+125°C, -55°C	2	33	ns
	TPHL	VCC = 4.5V	9	+25°C	2	35	ns
			10, 11	+125°C, -55°C	2	38	ns
CE to RC	TPLH	VCC = 4.5V	9	+25°C	2	20	ns
			10, 11	+125°C, -55°C	2	21	ns
	TPHL	VCC = 4.5V	9	+25°C	2	29	ns
			10, 11	+125°C, -55°C	2	31	ns

NOTES:

1. All voltages referenced to device GND.
2. AC measurements assume RL = 500Ω, CL = 50pF, Input TR = TF = 3ns, VIL = GND, VIH = 3V.

Specifications HCTS190MS

TABLE 3. ELECTRICAL PERFORMANCE CHARACTERISTICS

PARAMETER	SYMBOL	(NOTE 1) CONDITIONS	TEMPERATURE	LIMITS		UNITS
				MIN	MAX	
Capacitance Power Dissipation	CPD	VCC = 5.0V, f = 1MHz	+25°C	-	60	pF
			+125°C, -55°C	-	128	pF
Input Capacitance	CIN	VCC = 5.0V, f = 1MHz	+25°C	-	10	pF
			+125°C, -55°C	-	10	pF
Output Transition Time	TTHL TTLH	VCC = 4.5V	+25°C	-	15	ns
			+125°C, -55°C	-	22	ns
Maximum Operating Frequency (CPU, CPD)	FMAX	VCC = 4.5V	+25°C		30	MHz
			+125°C, -55°C		20	MHz
Setup Time Pn to \overline{PL}	TSU	VCC = 4.5V	+25°C	12	-	ns
			+125°C, -55°C	18	-	ns
Setup Time \overline{CE} to CP	TSU	VCC = 4.5V	+25°C	12	-	ns
			+125°C, -55°C	18	-	ns
Setup Time \overline{UD} to CP	TSU	VCC = 4.5V	+25°C	18	-	ns
			+125°C, -55°C	27	-	ns
Hold Time Pn to \overline{PL}	TH	VCC = 4.5V	+25°C	2	-	ns
			+125°C, -55°C	2	-	ns
Hold Time \overline{CE} to CP	TH	VCC = 4.5V	+25°C	2	-	ns
			+125°C, -55°C	2	-	ns
Hold Time \overline{UD} to CP	TH	VCC = 4.5V	+25°C	0	-	ns
			+125°C, -55°C	0	-	ns
Recovery Time	TREC	VCC = 4.5V	+25°C	12	-	ns
			+125°C, -55°C	18	-	ns
CP Pulse Width	TW	VCC = 4.5V	+25°C	16	-	ns
			+125°C, -55°C	24	-	ns
PLN Pulse Width	TW	VCC = 4.5V	+25°C	20		ns
			+125°C, -55°C	30		ns

NOTE:

- The parameters listed in Table 3 are controlled via design or process parameters. Min and Max Limits are guaranteed but not directly tested. These parameters are characterized upon initial design release and upon design changes which affect these characteristics.

TABLE 4. DC POST RADIATION ELECTRICAL PERFORMANCE CHARACTERISTICS

PARAMETER	SYMBOL	(NOTES 1, 2) CONDITIONS	TEMPERATURE	200K RAD LIMITS		UNITS
				MIN	MAX	
Quiescent Current	ICC	VCC = 5.5V, VIN = VCC or GND	+25°C	-	0.75	mA
Output Current (Sink)	IOL	VCC = 4.5V, VIN = VCC or GND, VOUT = 0.4V	+25°C	4.0	-	mA
Output Current (Source)	IOH	VCC = 4.5V, VIN = VCC or GND, VOUT = VCC - 0.4V	+25°C	-4.0	-	mA

Specifications HCTS190MS

TABLE 4. DC POST RADIATION ELECTRICAL PERFORMANCE CHARACTERISTICS (Continued)

PARAMETER	SYMBOL	(NOTES 1, 2) CONDITIONS	TEMPERATURE	200K RAD LIMITS		UNITS
				MIN	MAX	
Output Voltage Low	VOL	VCC = 4.5V and 5.5V, VIH = VCC/2, VIL = 0.8V, IOL = 50μA	+25°C	-	0.1	V
Output Voltage High	VOH	VCC = 4.5V and 5.5V, VIH = VCC/2, VIL = 0.8V, IOH = -50μA	+25°C	VCC -0.1	-	V
Input Leakage Current	IIN	VCC = 5.5V, VIN = VCC or GND	+25°C	-	±5	μA
Noise Immunity Functional Test	FN	VCC = 4.5V, VIH = 2.25V, VIL = 0.8V, (Note 3)	+25°C	-	-	-
\overline{P} L to Qn	TPLH	VCC = 4.5V	+25°C	2	37	ns
	TPHL	VCC = 4.5V	+25°C	2	44	ns
Pn to Qn	TPLH	VCC = 4.5V	+25°C	2	24	ns
	TPHL	VCC = 4.5V	+25°C	2	41	ns
CP to Qn	TPLH	VCC = 4.5V	+25°C	2	29	ns
	TPHL	VCC = 4.5V	+25°C	2	27	ns
Cp to \overline{R} C	TPLH	VCC = 4.5V	+25°C	2	19	ns
	TPHL	VCC = 4.5V	+25°C	2	29	ns
CP to TC	TPLH	VCC = 4.5V	+25°C	2	39	ns
	TPHL	VCC = 4.5V	+25°C	2	39	ns
\overline{U} /D to \overline{R} C	TPLH	VCC = 4.5V	+25°C	2	36	ns
	TPHL	VCC = 4.5V	+25°C	2	38	ns
\overline{U} /D to TC	TPLH	VCC = 4.5V	+25°C	2	33	ns
	TPHL	VCC = 4.5V	+25°C	2	38	ns
\overline{C} E to \overline{R} C	TPLH	VCC = 4.5V	+25°C	2	21	ns
	TPHL	VCC = 4.5V	+25°C	2	31	ns

NOTES:

1. All voltages referenced to device GND.
2. AC measurements assume RL = 500Ω, CL = 50pF, Input TR = TF = 3ns, VIL = GND, VIH = 3V.
3. For functional tests VO ≥ 4.0V is recognized as a logic "1", and VO ≤ 0.5V is recognized as a logic "0".

TABLE 5. BURN-IN AND OPERATING LIFE TEST, DELTA PARAMETERS (+25°C)

PARAMETER	GROUP B SUBGROUP	DELTA LIMIT
ICC	5	12μA
IOL/IOH	5	-15% of 0 Hour

Specifications HCTS190MS

TABLE 6. APPLICABLE SUBGROUPS

CONFORMANCE GROUPS		METHOD	GROUP A SUBGROUPS	READ AND RECORD
Initial Test (Preburn-In)		100%/5004	1, 7, 9	ICC, IOL/H
Interim Test I (Postburn-In)		100%/5004	1, 7, 9	ICC, IOL/H
Interim Test II (Postburn-In)		100%/5004	1, 7, 9	ICC, IOL/H
PDA		100%/5004	1, 7, 9, Deltas	
Interim Test III (Postburn-In)		100%/5004	1, 7, 9	ICC, IOL/H
PDA		100%/5004	1, 7, 9, Deltas	
Final Test		100%/5004	2, 3, 8A, 8B, 10, 11	
Group A (Note 1)		Sample/5005	1, 2, 3, 7, 8A, 8B, 9, 10, 11	
Group B	Subgroup B-5	Sample/5005	1, 2, 3, 7, 8A, 8B, 9, 10, 11, Deltas	Subgroups 1, 2, 3, 9, 10, 11, (Note 2)
	Subgroup B-6	Sample/5005	1, 7, 9	
Group D		Sample/5005	1, 7, 9	

NOTES:

1. Alternate group A testing in accordance with method 5005 of MIL-STD-883 may be exercised.
2. Table 5 parameters only.

TABLE 7. TOTAL DOSE IRRADIATION

CONFORMANCE GROUPS	METHOD	TEST		READ AND RECORD	
		PRE RAD	POST RAD	PRE RAD	POST RAD
Group E Subgroup 2	5005	1, 7, 9	Table 4	1, 9	Table 4 (Note 1)

NOTE:

1. Except FN test which will be performed 100% Go/No-Go

TABLE 8. STATIC AND DYNAMIC BURN-IN TEST CONNECTIONS

OPEN	GROUND	1/2 VCC = 3V ± 0.5V	VCC = 6V ± 0.5V	OSCILLATOR	
				50kHz	25kHz
STATIC BURN-IN I TEST CONNECTIONS (Note 1)					
2, 3, 6, 7, 12, 13	1, 4, 5, 8 - 11, 14, 15	-	16	-	-
STATIC BURN-IN II TEST CONNECTIONS (Note 1)					
2, 3, 6, 7, 12, 13	8	-	1, 4, 5, 9 - 11, 14 - 16	-	-
DYNAMIC BURN-IN TEST CONNECTIONS (Note 2)					
-	1, 4, 5, 8 - 10, 15	2, 3, 6, 7, 12, 13	11, 16	14	-

NOTES:

1. Each pin except VCC and GND will have a resistor of 10KΩ ± 5% for static burn-in
2. Each pin except VCC and GND will have a resistor of 1KΩ ± 5% for dynamic burn-in

TABLE 9. IRRADIATION TEST CONNECTIONS

OPEN	GROUND	VCC = 5V ± 0.5V
2, 3, 6, 7, 12, 13	8	1, 4, 5, 9 - 11, 14 - 16

NOTE: Each pin except VCC and GND will have a resistor of 47KΩ ± 5% for irradiation testing. Group E, Subgroup 2, sample size is 4 dice/wafer 0 failures.

HCTS190MS

Harris Space Level Product Flow - 'MS'

Wafer Lot Acceptance (All Lots) Method 5007 (Includes SEM)	100% Interim Electrical Test 1 (T1) 100% Delta Calculation (T0-T1)
GAMMA Radiation Verification (Each Wafer) Method 1019, 4 Samples/Wafer, 0 Rejects	100% Static Burn-In 2, Condition A or B, 24 hrs. min., +125°C min., Method 1015
100% Nondestructive Bond Pull, Method 2023	100% Interim Electrical Test 2 (T2)
Sample - Wire Bond Pull Monitor, Method 2011	100% Delta Calculation (T0-T2)
Sample - Die Shear Monitor, Method 2019 or 2027	100% PDA 1, Method 5004 (Notes 1 and 2)
100% Internal Visual Inspection, Method 2010, Condition A	100% Dynamic Burn-In, Condition D, 240 hrs., +125°C or Equivalent, Method 1015
100% Temperature Cycle, Method 1010, Condition C, 10 Cycles	100% Interim Electrical Test 3 (T3)
100% Constant Acceleration, Method 2001, Condition per Method 5004	100% Delta Calculation (T0-T3)
100% PIND, Method 2020, Condition A	100% PDA 2, Method 5004 (Note 2)
100% External Visual	100% Final Electrical Test
100% Serialization	100% Fine/Gross Leak, Method 1014
100% Initial Electrical Test (T0)	100% Radiographic, Method 2012 (Note 3)
100% Static Burn-In 1, Condition A or B, 24 hrs. min., +125°C min., Method 1015	100% External Visual, Method 2009 Sample - Group A, Method 5005 (Note 4) 100% Data Package Generation (Note 5)

NOTES:

1. Failures from Interim electrical test 1 and 2 are combined for determining PDA 1.
2. Failures from subgroup 1, 7, 9 and deltas are used for calculating PDA. The maximum allowable PDA = 5% with no more than 3% of the failures from subgroup 7.
3. Radiographic (X-Ray) inspection may be performed at any point after serialization as allowed by Method 5004.
4. Alternate Group A testing may be performed as allowed by MIL-STD-883, Method 5005.
5. Data Package Contents:
 - Cover Sheet (Harris Name and/or Logo, P.O. Number, Customer Part Number, Lot Date Code, Harris Part Number, Lot Number, Quantity).
 - Wafer Lot Acceptance Report (Method 5007). Includes reproductions of SEM photos with percent of step coverage.
 - GAMMA Radiation Report. Contains Cover page, disposition, Rad Dose, Lot Number, Test Package used, Specification Numbers, Test equipment, etc. Radiation Read and Record data on file at Harris.
 - X-Ray report and film. Includes penetrometer measurements.
 - Screening, Electrical, and Group A attributes (Screening attributes begin after package seal).
 - Lot Serial Number Sheet (Good units serial number and lot number).
 - Variables Data (All Delta operations). Data is identified by serial number. Data header includes lot number and date of test.
 - The Certificate of Conformance is a part of the shipping invoice and is not part of the Data Book. The Certificate of Conformance is signed by an authorized Quality Representative.

AC Timing Diagrams

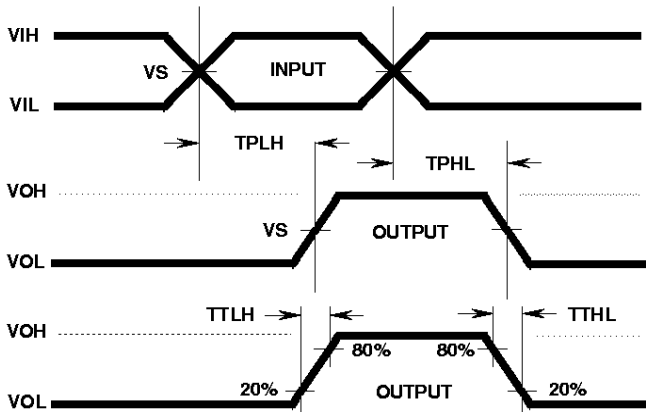

AC Load Circuit

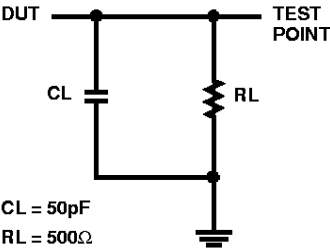

AC VOLTAGE LEVELS

PARAMETER	HCTS	UNITS
VCC	4.50	V
VIH	3.00	V
VS	1.30	V
VIL	0	V
GND	0	V

HCTS190MS

Die Characteristics

DIE DIMENSIONS:

104 x 86 mils

METALLIZATION:

Type: AlSi

Metal Thickness: $11\text{k}\text{\AA} \pm 1\text{k}\text{\AA}$

GLASSIVATION:

Type: SiO_2

Thickness: $13\text{k}\text{\AA} \pm 2.6\text{k}\text{\AA}$

WORST CASE CURRENT DENSITY:

$< 2.0 \times 10^5 \text{A/cm}^2$

BOND PAD SIZE:

$100\mu\text{m} \times 100\mu\text{m}$

4 mils x 4 mils

Metallization Mask Layout

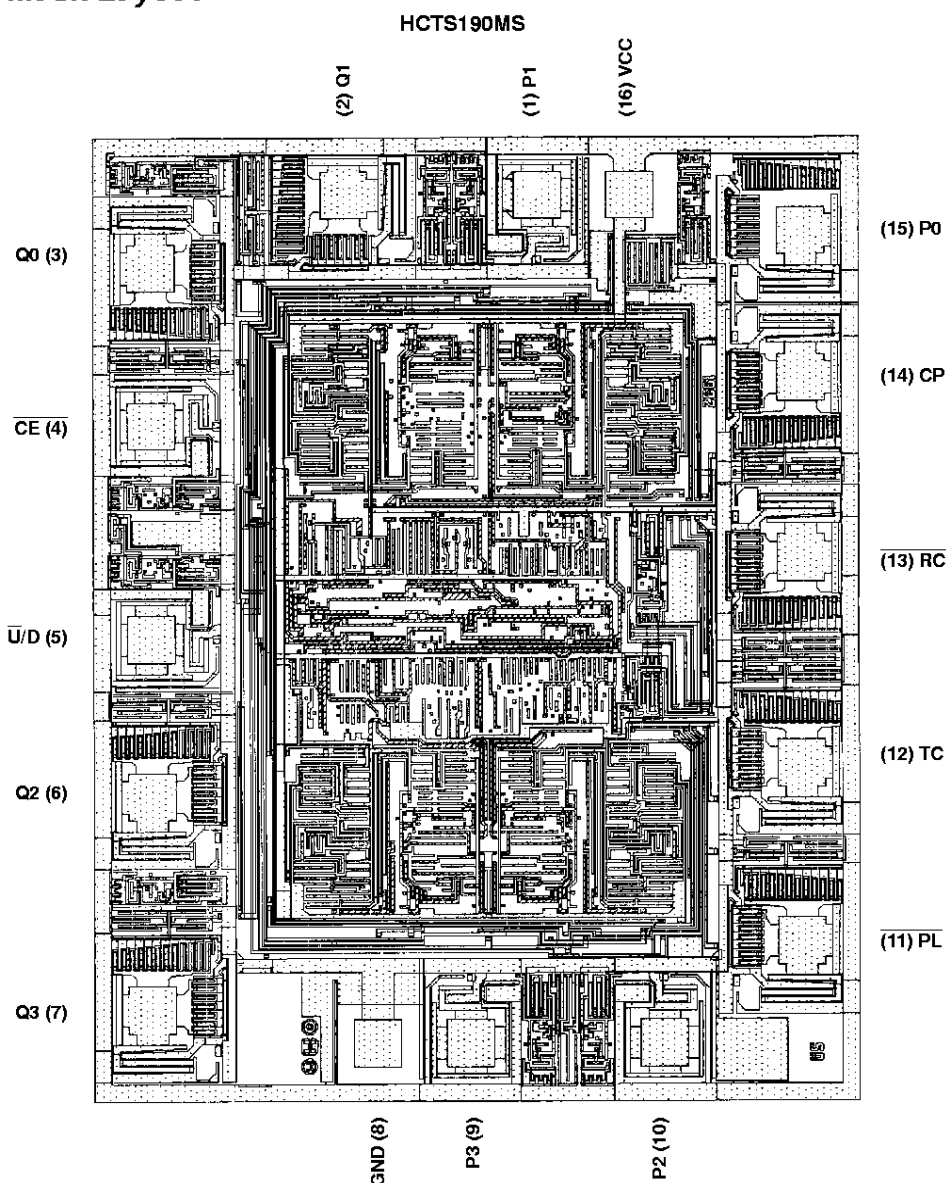

NOTE: The die diagram is a generic plot from a similar HCS device. It is intended to indicate approximate die size and bond pad location.
The mask series for the HCTS190 is TA14444A.