

N-CHANNEL SILICON POWER MOSFET

F- V SERIES

Features

- Include fast recovery diode
- High voltage
- Low driving power

Applications

- Motor controllers
- Inverters
- Choppers

Outline Drawings

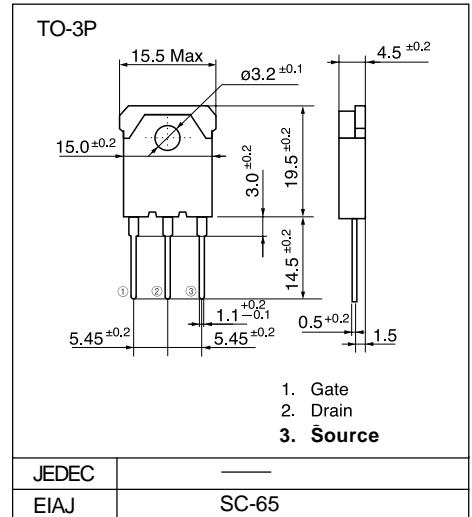

Maximum ratings and characteristics

Absolute maximum ratings (T_c=25°C unless otherwise specified)

Item	Symbol	Rating	Unit
Drain-source voltage	V _{DS}	500	V
Continuous drain current	I _D	18	A
Pulsed drain current	I _{D(puls)}	72	A
Continuous reverse drain current	I _{DR(puls)}	18	A
Gate-source peak voltage	V _{GS}	±20	V
Max. power dissipation	P _D	150	W
Operating and storage temperature range	T _{ch} T _{stg}	+150 -55 to +150	°C

Equivalent circuit schematic

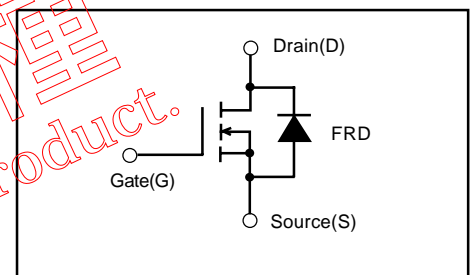

Electrical characteristics (T_c =25°C unless otherwise specified)

Item	Symbol	Test Conditions	Min.	Typ.	Max.	Units
Drain-source breakdown voltage	V _{(BR)DSS}	I _D =1mA V _{GS} =0V	500			V
Gate threshold voltage	V _{GS(th)}	I _D =10mA V _{DS} =V _{GS}	2.1	3.0	4.0	V
Zero gate voltage drain current	I _{DSS}	V _{DS} =500V V _{GS} =0V T _{ch} =25°C		10	500	μA
Gate-source leakage current	I _{GSS}	V _{GS} =±20V V _{DS} =0V		10	100	nA
Drain-source on-state resistance	R _{DS(on)}	I _D =9A V _{GS} =10V		0.35	0.5	Ω
Forward transconductance	g _{fs}	I _D =9A V _{DS} =25V	8.0	15.0		S
Input capacitance	C _{iss}	V _{DS} =25V		2400	3600	pF
Output capacitance	C _{oss}	V _{GS} =0V		300	450	pF
Reverse transfer capacitance	C _{rss}	f=1MHz		150	220	pF
Turn-on time t _{on} (t _{on} =t _{d(on)} +t _r)	t _{d(on)} t _r	V _{CC} =300V R _G =25 Ω I _D =18A		35 150	50 220	ns
Turn-off time t _{off} (t _{off} =t _{d(off)} +t _f)	t _{d(off)} t _f	V _{GS} =10V		450 180	650 270	ns
Diode forward on-voltage	V _{SD}	I _F =I _{DR} V _{GS} =0V T _{ch} =25°C		0.85	1.6	V
Reverse recovery time	t _{rr}	I _F =I _{DR} di/dt=100A/μs T _{ch} =25°C		150	200	ns

Thermal characteristics

Item	Symbol	Test Conditions	Min.	Typ.	Max.	Units
Thermal resistance	R _{th(ch-a)}	channel to ambient			35.0	°C/W
	R _{th(ch-c)}	channel to case			0.83	°C/W

Characteristics

Typical output characteristics

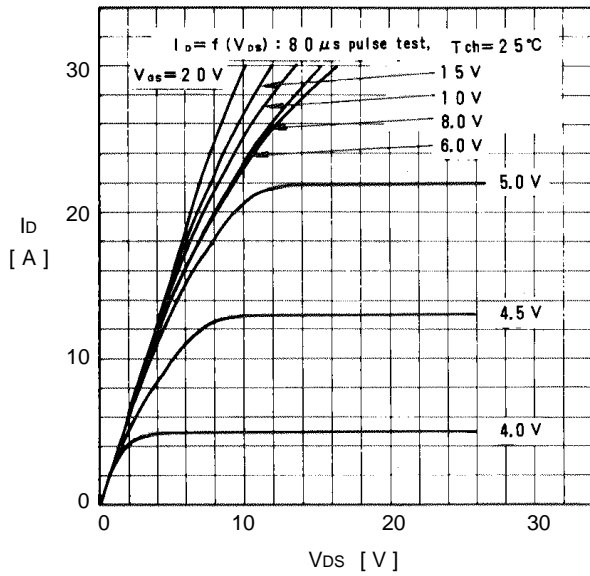

On state resistance vs. T_{ch}

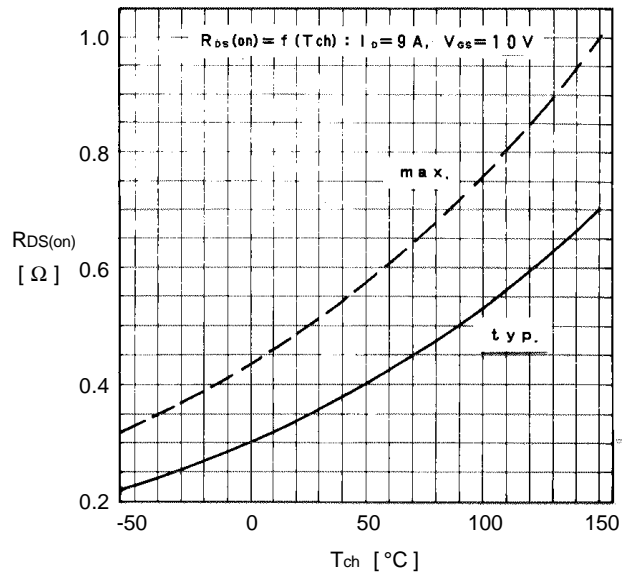

Typical transfer characteristics

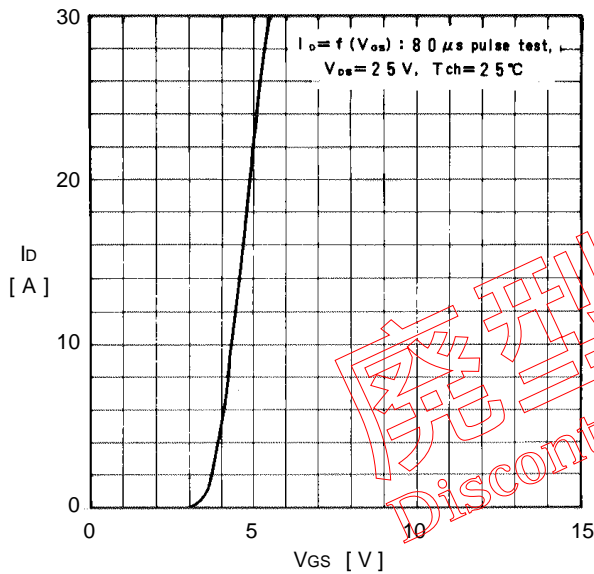

Typical Drain-Source on state resistance vs. I_D

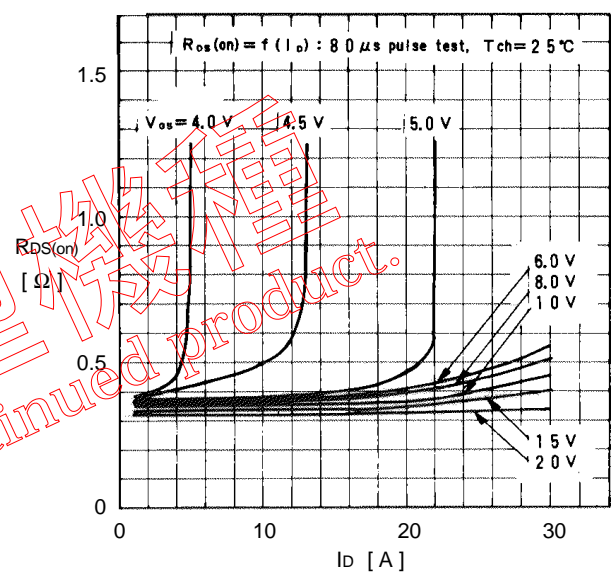

Typical forward transconductance vs. I_D

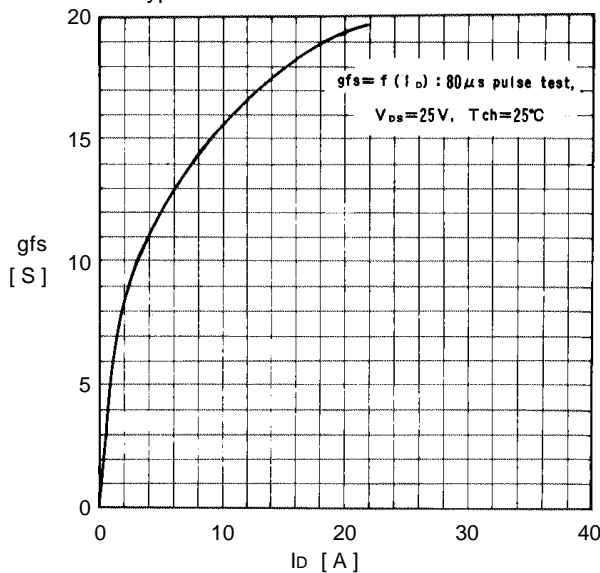

Gate threshold voltage vs. T_{ch}

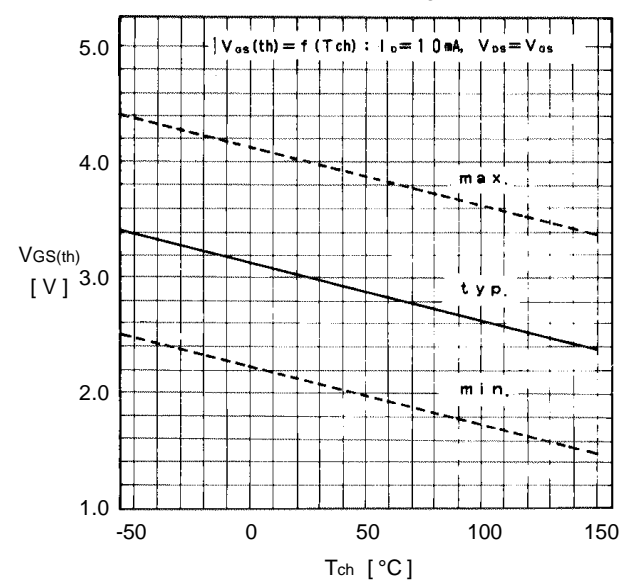

Typical capacitance vs. V_{DS}

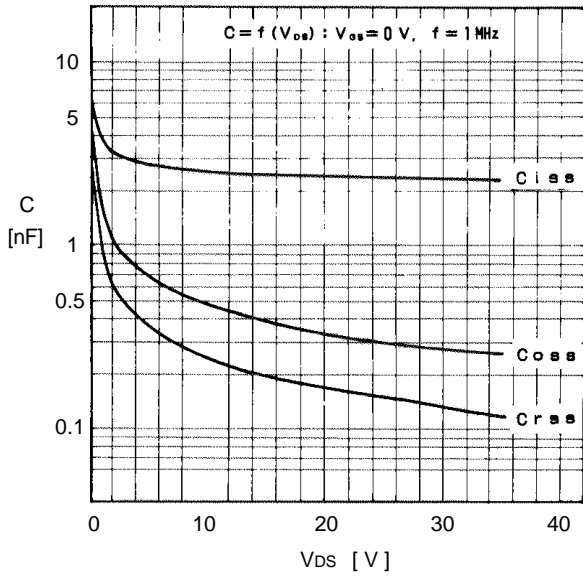

Typical input charge

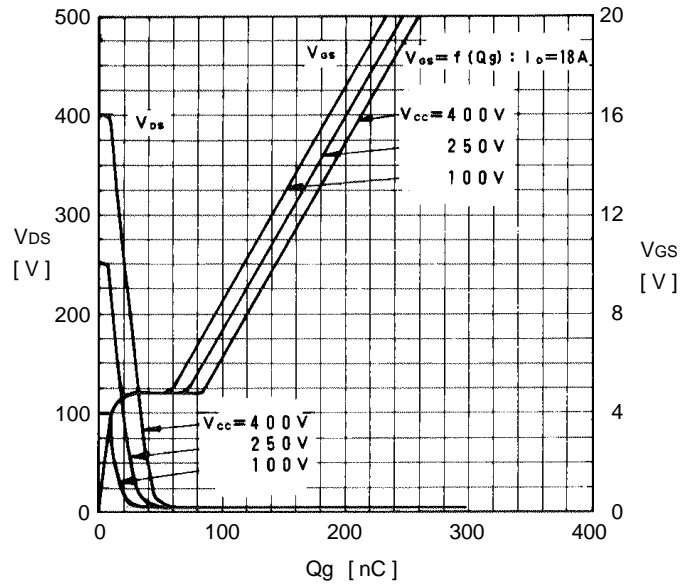

Forward characteristics of reverse diode

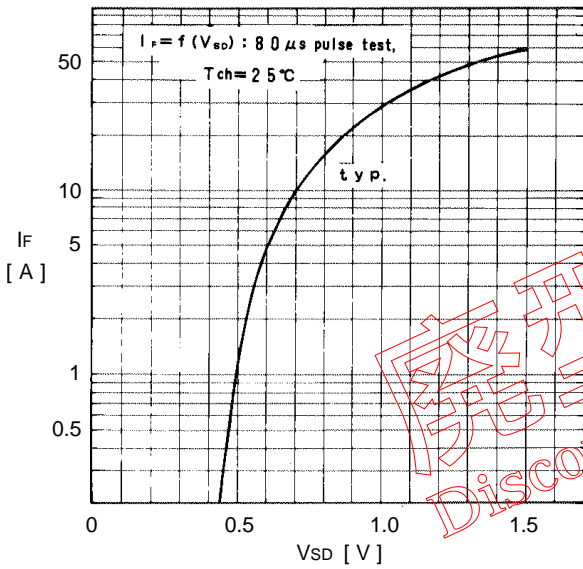

Allowable power dissipation vs. T_c

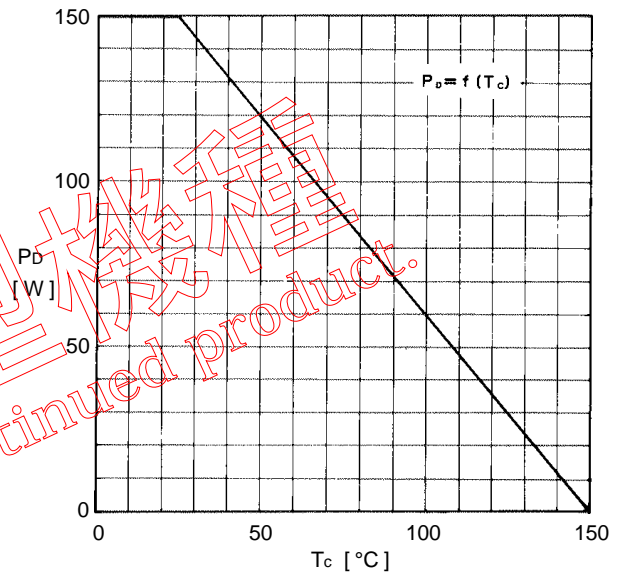

Safe operating area

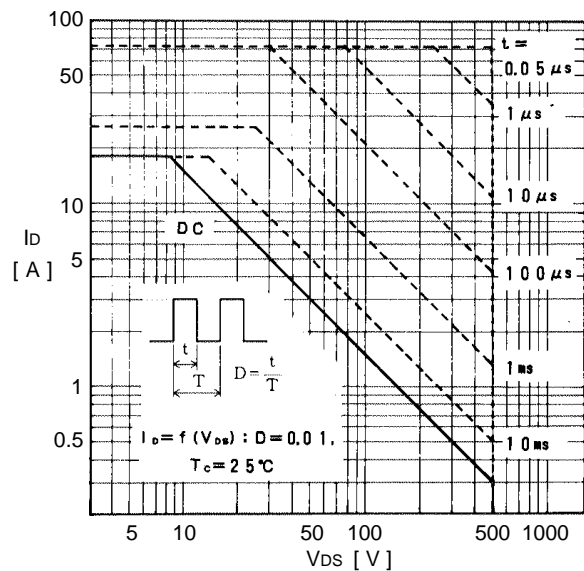

Transient thermal impedance

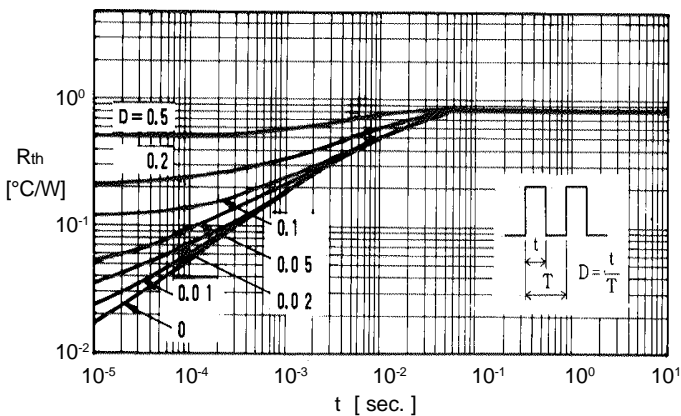

I_F-di/dt characteristics of reverse diode

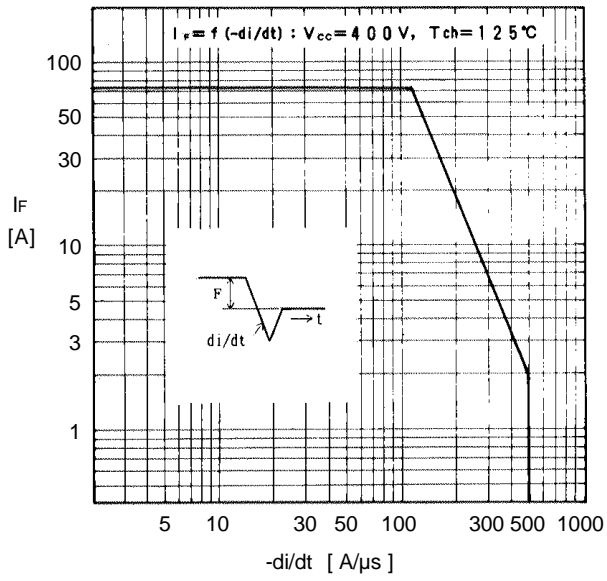

Reverse recovery characteristics

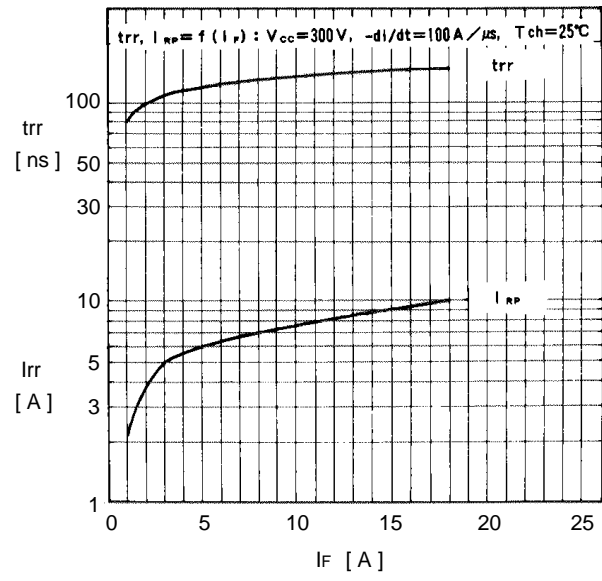

廃型機種
Discontinued product.