

# T1 Repeater Equalization Hybrid Module

## GENERAL DESCRIPTION

The TM-044H is a passive equalizer module designed for use in conjunction with the XR-C277 repeater/receiver family. The TM-044H provides a complete solution for T1 PCM line repeater or line termination units. Using hybrid technology, the TM-044H replaces 17 precision external components normally required for T1 line equalization (up to 36 dB of cable loss), with automatic line build out (ALBO) and filter network. This simple front stage network provides space saving, enhanced performance, increased reliability and reduction in manufacturing costs.

## FEATURES

- Line Equalization Optimized to 2.048 MBPS
- Complete ALBO Circuitry
- Smoothing ALBO Filter Network
- Fixed Gain and Compensation Network
- Improved Crosstalk and Noise Through Simplified Layout

## APPLICATIONS

- T1 PCM Line Repeaters and Receivers
- CPI
- DMI
- T1 Test and Maintenance Equipment

## ABSOLUTE MAXIMUM RATINGS

|  |                 |
|--|-----------------|
| Storage Temperature Range                | -55°C to +150°C |
| Lead Temperature (Soldering, 10 seconds) | 300°C           |

## ORDERING INFORMATION

| Part Number | Package        | Operating Temperature |
|-------------|----------------|-----------------------|
| TM-044H     | Ceramic Hybrid | -40°C to +85°C        |

## PIN ASSIGNMENT

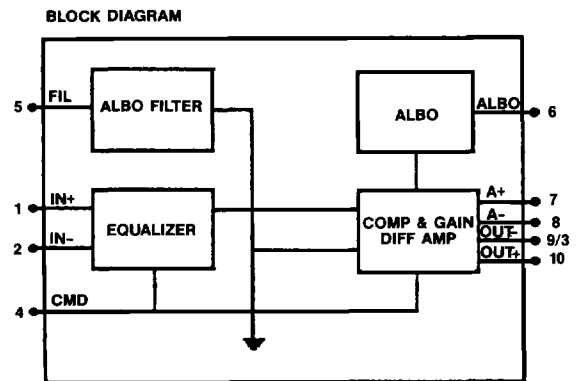

SIMPLIFIED FUNCTIONAL BLOCK DIAGRAM OF TM-044H

## DIMENSIONS

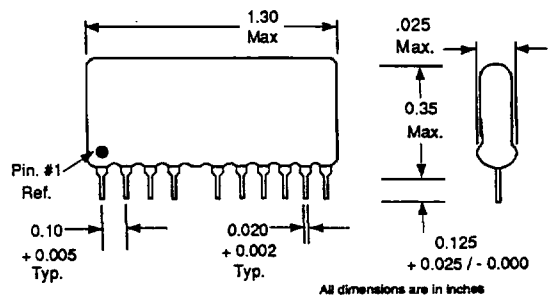

## SYSTEM DESCRIPTION

The equalizer module includes all the front end circuitry necessary to equalize the incoming bipolar signals, which are attenuated and distorted due to the transmission medium. It is the function of the equalizer when working with the preamplifier of the repeater to provide the necessary amount of gain and phase equalization, so that the attenuated incoming data can be faithfully extracted and regenerated. In addition, the network band limits the input signal in order to optimize the performance of the repeater for near-end crosstalk produced by other systems operating within the same cable bundle.

The ALBO Network is providing an Automatic-Gain-Control for the preamplifier in the feedback loop, such that all input signals applied to the preamplifier will appear to be transmitted from the same cable length, which is usually set at 6,000 ft. The TM-044H also includes our ALBO filter that determines the ALBO time constant for optimum performance.

Other circuits included in the module is a preamplifier gain adjustment network and a simple high pass filter that further reduces any noise on the signals before they are applied to the input of the repeater. The preamplifier gain is set at around 40dB and this enables the preamplifier to recover signals which have been attenuated more than 36dB.

## PIN DESCRIPTION

| Pins | Name | Description   |
|------|------|---|
| 1-2  |      | Network Input Pins. These two pins connect directly to the secondary side of the isolation transformer. A line termination resistor to minimize reflections and possibly a trimming resistor may be required to maximize performance. |
| 3    |      | This Output pin is connected directly to the negative pre-amplifier output. (XR-C277 pin 4).  |
| 4    |      | Ground. (XR-C277 pin 6).  |
| 5    |      | Automatic Line Build Out (ALBO) smoothing filter input pin. (XR-C277 pin 16).   |
| 6    |      | This input is part of the ALBO feedback network and connects directly to the ALBO output port. (XR-C277 pin 1).   |
| 7    |      | Preamplifier negative input pin. (XR-C277 pin 2).   |
| 8    |      | Preamplifier positive input pin. (XR-C277 pin 3).   |
| 9    |      | Same as pin 3. (XR-C277 pin 4).   |
| 10   |      | This pin connects to the pre-amplifier negative output pin and determines the preamplifier gain. (XR-C277 pin 5).   |

## DC ELECTRICAL CHARACTERISTICS

Test Conditions:  $V_{CC} = 5V \pm 10\%$ ,  $T_A = 25^\circ C$ , unless otherwise specified.

| SYMBOL | PARAMETER          | UNIT       | MIN | TYP   | MAX | CONDITIONS |
|--------|--------------------|------------|-----|-------|-----|------------|
| f-in   | Input Frequency    | MHz        |     | 2.048 |     |            |
| Zin    | Input Impedance    | k $\Omega$ | 3   |       |     |            |
| t-ALBO | ALBO Time Constant | ns         |     | 20    |     |            |
| f-ALBO | ALBO Pole          | kHz        |     | 60    |     |            |

# XR-TM044H

