

<b>HIGH PERFORMANCE V52C8126</b>	<b>70</b>	<b>80</b>	<b>10</b>
Max. $\overline{\text{RAS}}$ Access Time, ( $t_{\text{RAC}}$ )	70 ns	80 ns	100 ns
Max. $\overline{\text{CAS}}$ Access Time, ( $t_{\text{CAC}}$ )	20 ns	25 ns	25 ns
Max. Column Address Access Time, ( $t_{\text{AA}}$ )	35 ns	40 ns	50 ns
Min. Fast Page Mode Cycle Time, ( $t_{\text{PC}}$ )	45 ns	50 ns	55 ns
Min. Read/Write Cycle Time, ( $t_{\text{RC}}$ )	140 ns	150 ns	180 ns
Max. Serial Access Time, ( $t_{\text{SCA}}$ )	25 ns	25 ns	25 ns
Min. Serial Port Cycle Time, ( $t_{\text{SCC}}$ )	30 ns	30 ns	30 ns

### Features

- Organization
  - RAM Port: 131,072 words x 8 bits
  - SAM Port: 256 words x 8 bits
- RAM Port
  - Fast Page Mode, Read-Modify-Write, Write-Per-Bit
  - $\overline{\text{CAS}}$ -before- $\overline{\text{RAS}}$  Refresh, Hidden Refresh,  $\overline{\text{RAS}}$ -only Refresh
  - 512 Refresh Cycles/8 ms
- SAM Port
  - High Speed Serial Read/Write Capability
  - 256 Tap Locations
  - Fully Static Register
- RAM-SAM Bidirectional Transfer
  - Read/Write/Pseudo Write Transfer
  - Real Time Read Transfer
- Low Power Dissipation
  - RAM Port Operating Alone – 90 mA
  - SAM Port Operating Alone – 50 mA
- Low Standby Current – 7 mA
- Package
  - 40 pin 400 mil SOJ
  - 40 pin 475 mil ZIP

### Description

The V52C8126 VRAM is equipped with a 131,072-words by 8-bits dynamic random access memory (RAM) port and a 256-words by 8-bits static serial access memory (SAM) port. The V52C8126 supports three types of operations: random access to and from the RAM port, high speed serial access to and from the SAM port, and bidirectional transfer of data between any selected row in the RAM port and the SAM port. The RAM port and the SAM port can be accessed independently except when data is being transferred between them internally.

The V52C8126 is fabricated in CMOS silicon gate process as well as advanced circuit designs to provide low power dissipation and wide operating margins.

### Device Usage Chart

Operating Temperature Range	Package Outline		Access Time (ns)			Power	Temperature Mark
	K	Z	70	80	100	Std	
0°C–70°C	•	•	•	•	•	•	Blank





**DC and Operating Characteristics** $(V_{DD} = 5V \pm 10\%, T_A = 0-70^\circ C)$ 

Symbol	Parameter (RAM Port)	SAM Port	V52C8126-70		V52C8126-80		V52C8126-10		Unit	Notes
			Min.	Max.	Min.	Max.	Min.	Max.		
I <sub>DD1</sub>	Operating Current RAS, CAS Cycling, t <sub>RC</sub> = t <sub>RC</sub> Min.	Standby		90		80		70	mA	1,2
		Active		125		115		105	mA	1,2
I <sub>DD2</sub>	Standby Current RAS, CAS = V <sub>IH</sub>	Standby		7		7		7	mA	
		Active		50		45		40	mA	1,2
I <sub>DD3</sub>	RAS-Only Refresh Current RAS Cycling, CAS = V <sub>IH</sub> , t <sub>RC</sub> = t <sub>RC</sub> Min.	Standby		90		80		70	mA	1,2
		Active		125		115		105	mA	1,2
I <sub>DD4</sub>	Page Mode Current RAS = V <sub>IL</sub> , CAS Cycling, t <sub>PC</sub> = t <sub>PC</sub> Min.	Standby		75		70		65	mA	1,2
		Active		125		115		105	mA	1,2
I <sub>DD5</sub>	CAS-before-RAS Refresh Current RAS Cycling, CAS before RAS, t <sub>RC</sub> = t <sub>RC</sub> Min.	Standby		90		80		70	mA	1,2
		Active		125		115		105	mA	1,2
I <sub>DD6</sub>	Data Transfer Current RAS, CAS Cycling, t <sub>RC</sub> = t <sub>RC</sub> Min.	Standby		90		80		70	mA	1,2
		Active		125		115		105	mA	1,2
I <sub>I(L)</sub>	Input Leakage Current 0V ≤ V <sub>IN</sub> ≤ 5.5V, all other pins not under test = 0V		-10	10	-10	10	-10	10	μA	
I <sub>O(L)</sub>	Output Leakage Current 0V ≤ V <sub>OUT</sub> ≤ 5.5V, Output Disable		-10	10	-10	10	-10	10	μA	
V <sub>OH</sub>	Output "H" Level Voltage I <sub>OUT</sub> = -2mA		2.4		2.4		2.4		V	
V <sub>OL</sub>	Output "L" Level Voltage I <sub>OUT</sub> = 2mA			0.4		0.4		0.4	V	
V <sub>IH</sub>	Input High Voltage		2.4	V <sub>DD</sub> + 1	2.4	V <sub>DD</sub> + 1	2.4	V <sub>DD</sub> + 1	V	
V <sub>IL</sub>	Input Low Voltage		-1.0	0.8	-1.0	0.8	-1.0	0.8	V	

3

**AC Electrical Characteristics** Notes: 3, 4, 5

Symbol	Parameter	V52C8126-70		V52C8126-80		V52C8126-10		Unit	Notes
		Min.	Max.	Min.	Max.	Min.	Max.		
$t_{RC}$	Random Read or Write Cycle Time	140		150		180		ns	
$t_{RMW}$	Read-Modify-Write Cycle Time	195		195		235		ns	
$t_{PC}$	Fast Page Mode Cycle Time	45		50		55		ns	
$t_{PRMW}$	Fast Page Mode Read-Modify-Write Cycle Time	90		90		100		ns	
$t_{RAC}$	Access Time from $\overline{RAS}$		70		80		100	ns	6, 12
$t_{AA}$	Access Time from Column Address		35		40		50	ns	6, 12
$t_{CAC}$	Access Time from $\overline{CAS}$		20		25		25	ns	6, 13
$t_{CPA}$	Access Time from $\overline{CAS}$ Precharge		40		45		50	ns	6, 13
$t_{OFF}$	Output Buffer Turn-Off Delay	0	20	0	20	0	20	ns	8
$t_T$	Transition Time (Rise and Fall)	3	35	3	35	3	35	ns	5
$t_{RP}$	$\overline{RAS}$ Precharge Time	60		60		70		ns	
$t_{RAS}$	$\overline{RAS}$ Pulse Width	70	10K	80	10K	100	10K	ns	
$t_{RASP}$	$\overline{RAS}$ Pulse Width (Fast Page Mode only)	70	100K	80	100K	100	100K	ns	
$t_{RSH}$	$\overline{RAS}$ Hold Time	20		25		25		ns	
$t_{CSH}$	$\overline{CAS}$ Hold Time	70		80		100		ns	
$t_{CAS}$	$\overline{CAS}$ Pulse Width	20	10K	25	10K	25	10K	ns	
$t_{RCD}$	$\overline{RAS}$ to $\overline{CAS}$ Delay Time	20	50	20	55	20	75	ns	12
$t_{RAD}$	$\overline{RAS}$ to Column Address Delay Time	15	35	15	40	20	50	ns	12
$t_{RAL}$	Column Address to $\overline{RAS}$ Lead Time	35		40		55		ns	
$t_{CRP}$	$\overline{CAS}$ to $\overline{RAS}$ Precharge Time	10		10		10		ns	
$t_{CPN}$	$\overline{CAS}$ Precharge Time	10		10		10		ns	
$t_{CP}$	$\overline{CAS}$ Precharge Time (Fast Page Mode)	10		10		10		ns	
$t_{ASR}$	Row Address Setup Time	0		0		0		ns	
$t_{RAH}$	Row Address Hold Time	10		10		10		ns	
$t_{ASC}$	Column Address Setup Time	0		0		0		ns	
$t_{CAH}$	Column Address Hold Time	15		15		15		ns	
$t_{AR}$	Column Address Hold Time referenced to $\overline{RAS}$	55		55		70		ns	
$t_{RCS}$	Read Command Setup Time	0		0		0		ns	
$t_{RCH}$	Read Command Hold Time	0		0		0		ns	9
$t_{RRH}$	Read Command Hold Time referenced to $\overline{RAS}$	0		0		0		ns	9
$t_{WCH}$	Write Command Hold Time	15		15		15		ns	
$t_{WCR}$	Write Command Hold Time referenced to $\overline{RAS}$	55		55		70		ns	
$t_{WP}$	Write Command Pulse Width	15		15		15		ns	

## AC Electrical Characteristics (Cont'd)

Symbol	Parameter	V52C8126-70		V52C8126-80		V52C8126-10		Unit	Notes
		Min.	Max.	Min.	Max.	Min.	Max.		
$t_{RWL}$	Write Command to $\overline{RAS}$ Lead Time	20		20		25		ns	
$t_{CWL}$	Write Command to $\overline{CAS}$ Lead Time	20		20		25		ns	
$t_{DS}$	Data Setup Time	0		0		0		ns	10
$t_{DH}$	Data Hold Time	15		15		15		ns	10
$t_{DHR}$	Data Hold Time referenced to $\overline{RAS}$	55		55		70		ns	
$t_{WCS}$	Write Command Setup Time	0		0		0		ns	11
$t_{RWD}$	$\overline{RAS}$ to $\overline{WE}$ Delay Time	100		100		130		ns	11
$t_{AWD}$	Column Address to $\overline{WE}$ Delay Time	65		65		80		ns	11
$t_{CWD}$	$\overline{CAS}$ to $\overline{WE}$ Delay Time	45		45		55		ns	11
$t_{DZC}$	Data to $\overline{CAS}$ Delay Time	0		0		0		ns	
$t_{DZO}$	Data to $\overline{OE}$ Delay Time	0		0		0		ns	
$t_{OEA}$	Access Time from $\overline{OE}$		20		20		25	ns	6
$t_{O EZ}$	Output Buffer Turn-Off Delay from $\overline{OE}$	0	10	0	10	0	20	ns	8
$t_{OED}$	$\overline{OE}$ to Data Delay Time	10		10		20		ns	
$t_{OEH}$	$\overline{OE}$ Command Hold Time	10		10		20		ns	
$t_{ROH}$	$\overline{RAS}$ Hold Time referenced to $\overline{OE}$	15		15		15		ns	
$t_{CSR}$	$\overline{CAS}$ Setup Time for $\overline{CAS}$ -before- $\overline{RAS}$ Cycle	10		10		10		ns	
$t_{CHR}$	$\overline{CAS}$ Hold Time for $\overline{CAS}$ -before- $\overline{RAS}$ Cycle	10		10		10		ns	
$t_{RPC}$	$\overline{RAS}$ Precharge to $\overline{CAS}$ Active Time	0		0		0		ns	
$t_{REF}$	Refresh Period		8		8		8	ms	
$t_{WSR}$	$\overline{WB}$ Setup Time	0		0		0		ns	
$t_{RWH}$	$\overline{WB}$ Hold Time	15		15		15		ns	
$t_{MS}$	Write-Per-Bit Mask Data Setup Time	0		0		0		ns	
$t_{MH}$	Write-Per-Bit Mask Data Hold Time	15		15		15		ns	
$t_{THS}$	$\overline{DT}$ High Setup Time	0		0		0		ns	
$t_{THH}$	$\overline{DT}$ High Hold Time	15		15		15		ns	
$t_{TLS}$	$\overline{DT}$ Low Setup Time	0		0		0		ns	
$t_{TLH}$	$\overline{DT}$ Low Hold Time	15	10K	15	10K	15	10K	ns	
$t_{RTH}$	$\overline{DT}$ Low Hold Time referenced to $\overline{RAS}$ (Real Time Read Transfer)	60	10K	65	10K	80	10K	ns	
$t_{ATH}$	$\overline{DT}$ Low Hold Time referenced to Column Address (Real Time Read Transfer)	25		30		30		ns	
$t_{CTH}$	$\overline{DT}$ Low Hold Time referenced to $\overline{CAS}$ (Real Time Read Transfer)	20		25		25		ns	

**AC Electrical Characteristics (Cont'd)**

Symbol	Parameter	V52C8126-70		V52C8126-80		V52C8126-10		Unit	Notes
		Min.	Max.	Min.	Max.	Min.	Max.		
t <sub>ESR</sub>	SE Setup Time referenced to RAS	0		0		0		ns	
t <sub>REH</sub>	SE Hold Time referenced to RAS	15		15		15		ns	
t <sub>TRP</sub>	DT to RAS Precharge Time	60		60		70		ns	
t <sub>TP</sub>	DT Precharge Time	20		20		30		ns	
t <sub>RSD</sub>	RAS to First SC Delay Time (Read Transfer)	70		80		100		ns	
t <sub>ASD</sub>	Column Address to First SC Delay Time (Read Transfer)	45		45		50		ns	
t <sub>CSD</sub>	CAS to First SC Delay Time (Read Transfer)	20		25		25		ns	
t <sub>TSL</sub>	Last SC to DT Lead Time (Real Time Read Transfer)	5		5		5		ns	
t <sub>TSR</sub>	DT to First SC Delay Time (Read Transfer)	15		15		15		ns	
t <sub>SRS</sub>	Last SC to RAS Setup Time (Serial Input)	25		25		30		ns	
t <sub>SRD</sub>	RAS to First SC Delay Time (Serial Input)	20		20		25		ns	
t <sub>SDD</sub>	RAS to Serial Input Delay Time	40		40		50		ns	
t <sub>SDZ</sub>	Serial Output Buffer Turn-Off Delay from RAS (Pseudo Write Transfer)	10	40	10	40	10	50	ns	8
t <sub>SCC</sub>	SC Cycle Time	30		30		30		ns	
t <sub>SC</sub>	SC Pulse Width (SC High Time)	10		10		10		ns	
t <sub>SCP</sub>	SC Precharge Time (SC Low Time)	10		10		10		ns	
t <sub>SCA</sub>	Access Time from SC		25		25		25	ns	7
t <sub>SOH</sub>	Serial Output Hold Time from SC	5		5		5		ns	
t <sub>SDS</sub>	Serial Input Setup Time	0		0		0		ns	
t <sub>SDH</sub>	Serial Input Hold Time	15		15		15		ns	
t <sub>SEA</sub>	Access Time from SE		25		25		25	ns	7
t <sub>SE</sub>	SE Pulse Width	25		25		25		ns	
t <sub>SEP</sub>	SE Precharge Time	25		25		25		ns	
t <sub>SEZ</sub>	Serial Output Buffer Turn-Off Delay from SE	0	20	0	20	0	20	ns	8
t <sub>SEZ</sub>	Serial Input to SE Delay Time	0		0		0		ns	
t <sub>SZS</sub>	Serial Input to First SC Delay Time	0		0		0		ns	
t <sub>SWS</sub>	Serial Write Enable Setup Time	5		5		5		ns	
t <sub>SWH</sub>	Serial Write Enable Hold Time	15		15		15		ns	
t <sub>SWIS</sub>	Serial Write Disable Setup Time	5		5		5		ns	
t <sub>SWIH</sub>	Serial Write Disable Hold Time	15		15		15		ns	

**Notes**

1. These parameters depend on cycle rate.
2. These parameters depend on output loading. Specified values are obtained with the output open.
3. An initial pause of 200 $\mu$ s is required after power-up, followed by any 8  $\overline{\text{RAS}}$  cycles ( $\overline{\text{DT}}/\overline{\text{OE}}$  "high") and any 8 SC cycles before proper device operation is achieved. In case of using internal refresh counter, a minimum of 8  $\overline{\text{CAS}}$ -before- $\overline{\text{RAS}}$  initialization cycles instead of 8  $\overline{\text{RAS}}$  cycles are required.
4. AC measurements assume  $t_T = 5$  ns.
5.  $V_{IH}$  (min.) and  $V_{IL}$  (max.) are reference levels for measuring timing of input signals. Also, transition times are measured between  $V_{IH}$  and  $V_{IL}$ .
6. RAM port outputs are measured with a load equivalent to 1 TTL load and 100 pF.  $D_{OUT}$  reference levels:  $V_{OH}/V_{OL} = 2.0V/0.8V$ .
7. SAM port outputs are measured with a load equivalent to 1 TTL load and 30 pF.  $D_{OUT}$  reference levels:  $V_{OH}/V_{OL} = 2.0V/0.8V$ .
8.  $t_{OFF}$  (max.),  $t_{OEZ}$  (max.),  $t_{SDZ}$  (max.) and  $t_{SEZ}$  (max.) define the time at which the outputs achieve the open circuit condition and are not referenced to output voltage levels.
9. Either  $t_{RCH}$  or  $t_{RRH}$  must be satisfied for a read cycle.
10. These parameters are referenced to  $\overline{\text{CAS}}$  leading edge of early write cycles and to  $\overline{\text{WB}}/\overline{\text{WE}}$  leading edge in  $\overline{\text{OE}}$ -controlled write cycles and read-modify-write cycles.
11.  $t_{WCS}$ ,  $t_{RWD}$ ,  $t_{CWD}$  and  $t_{AWD}$  are not restrictive operating parameters. They are included in the data sheet as electrical characteristics only. If  $t_{WCS} \geq t_{WCS}$  (min.), the cycle is an early write cycle and the data out pin will remain open circuit (high impedance) throughout the entire cycle. If  $t_{RWD} \geq t_{RWD}$  (min.),  $t_{CWD} \geq t_{CWD}$  (min.) and  $t_{AWD} \geq t_{AWD}$  (min.), the cycle is a read-modify-write cycle and the data out will contain data read from the selected cell. If neither of the above sets of conditions is satisfied, the condition of the data out (at access time) is indeterminate.
12. Operation within the  $t_{RCD}$  (max.) limit ensures that  $t_{RAC}$  (max.) can be met.  $t_{RCD}$  (max.) is specified as a reference point only; if  $t_{RCD}$  is greater than the specified  $t_{RCD}$  (max.) limit, then access time is controlled by  $t_{CAC}$ .
13. Operation within the  $t_{RAD}$  (max.) limit ensures that  $t_{RAC}$  (max.) can be met.  $t_{RAD}$  (max.) is specified as a reference point only; if  $t_{RAD}$  is greater than the specified  $t_{RAD}$  (max.) limit, then access time is controlled by  $t_{AA}$ .

TIMING WAVEFORMS

Read Cycle

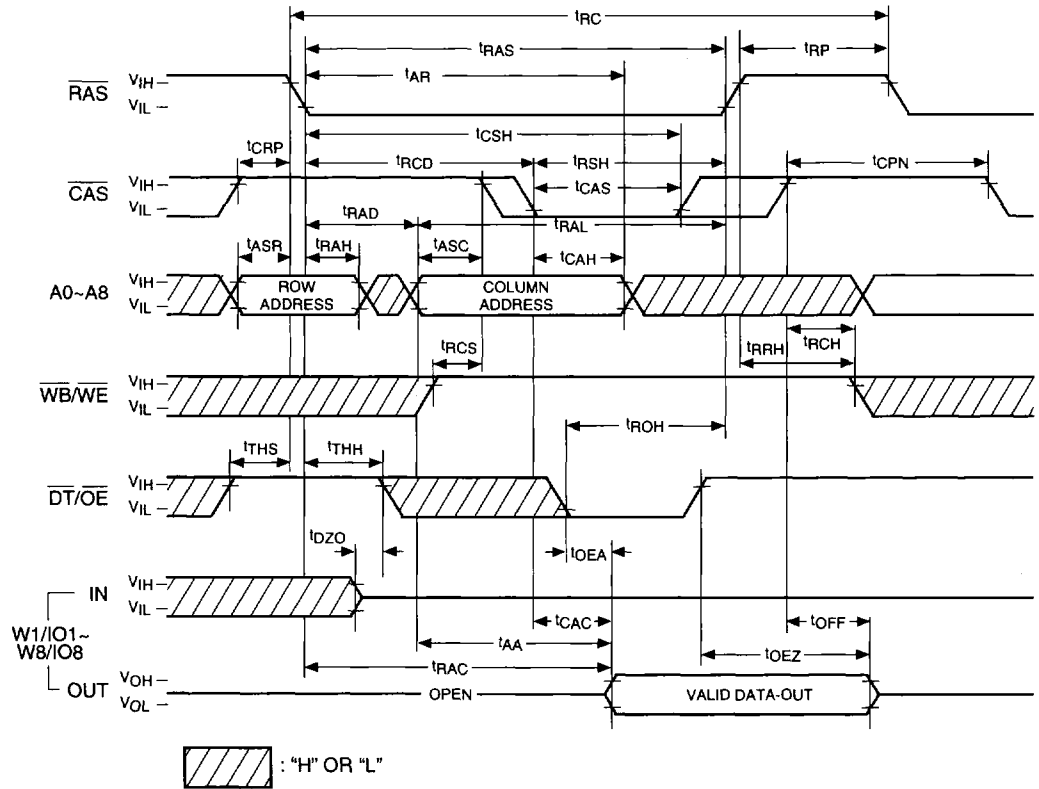

Write Cycle (Early Write)

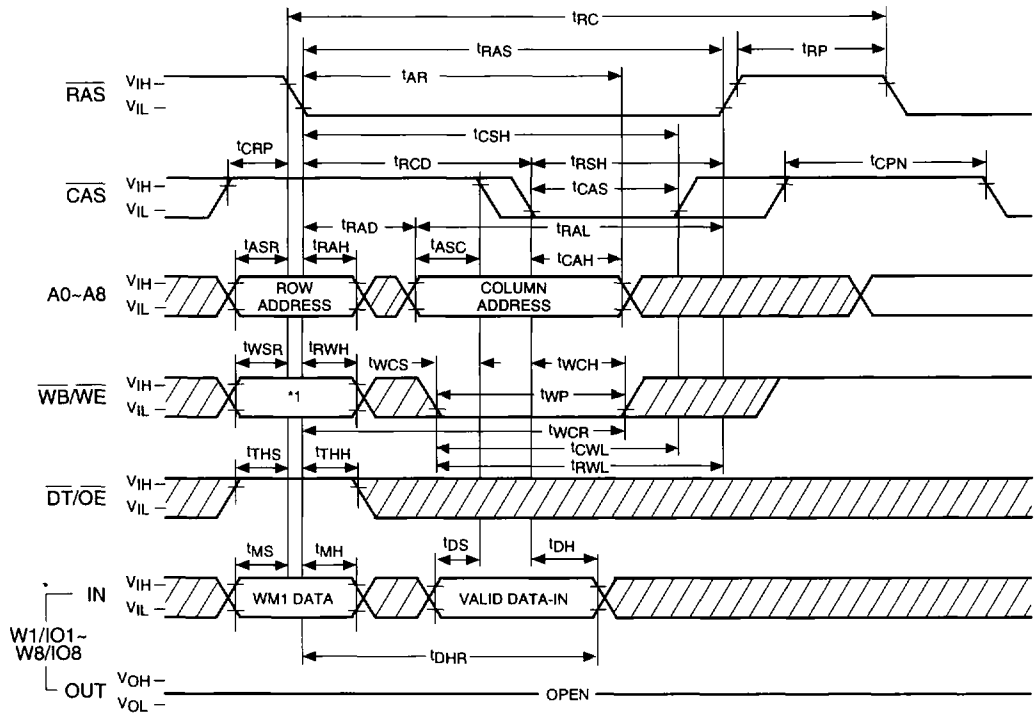

3

*1 $\overline{WB/WE}$	W1/IO1~W8/IO8	Cycle
0	WM1 data	Write per bit
1	Don't Care	Normal Write

WM1 data: 0: Write Disable  
1: Write Enable



Read-Modify-Write Cycle

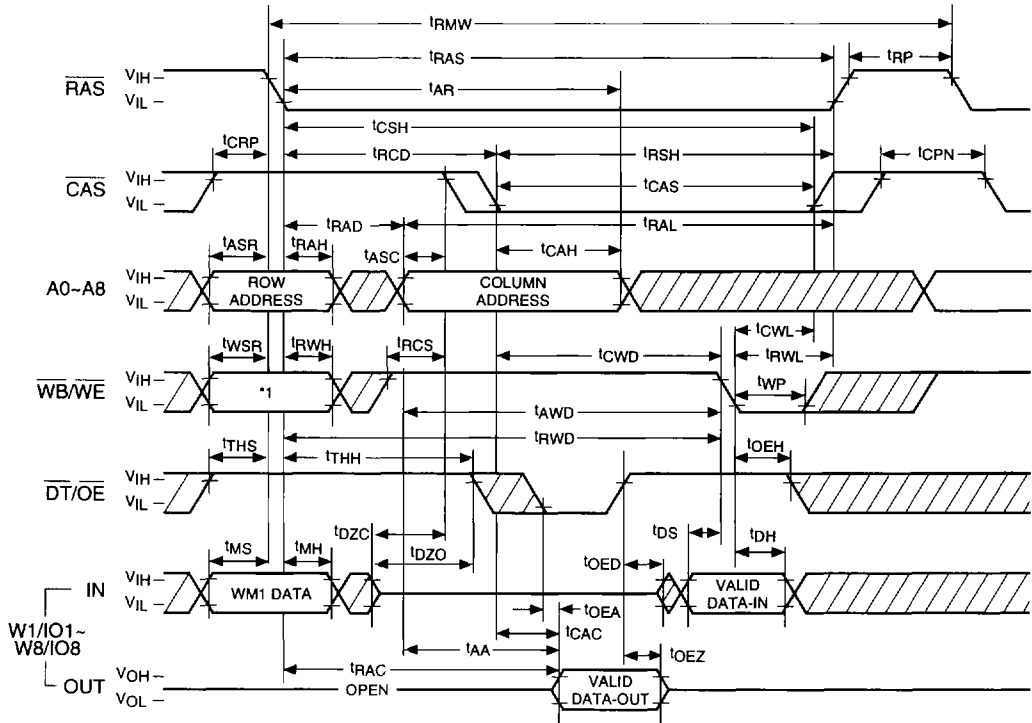

3

*1 $\overline{\text{WB/WE}}$	W1/IO1~W8/IO8	Cycle
0	WM1 data	Write per bit
1	Don't Care	Normal Write

: "H" OR "L"

WM1 data: 0: Write Disable  
1: Write Enable

**Fast Page Mode Read Cycle**

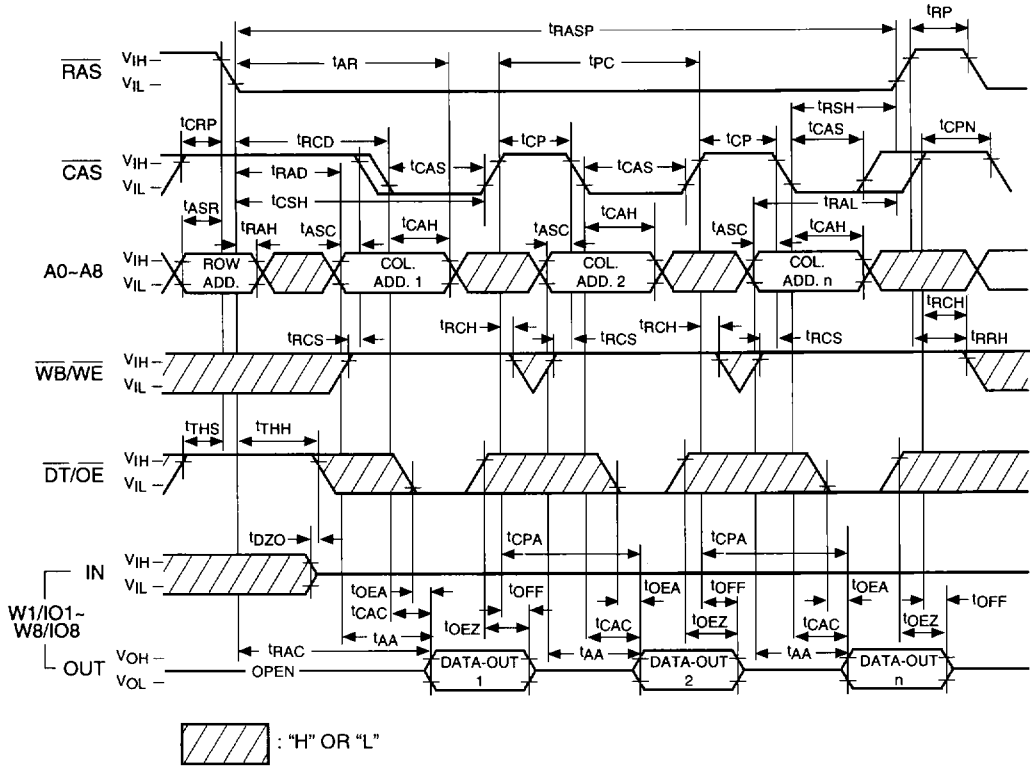

Fast Page Mode Write Cycle (Early Write)

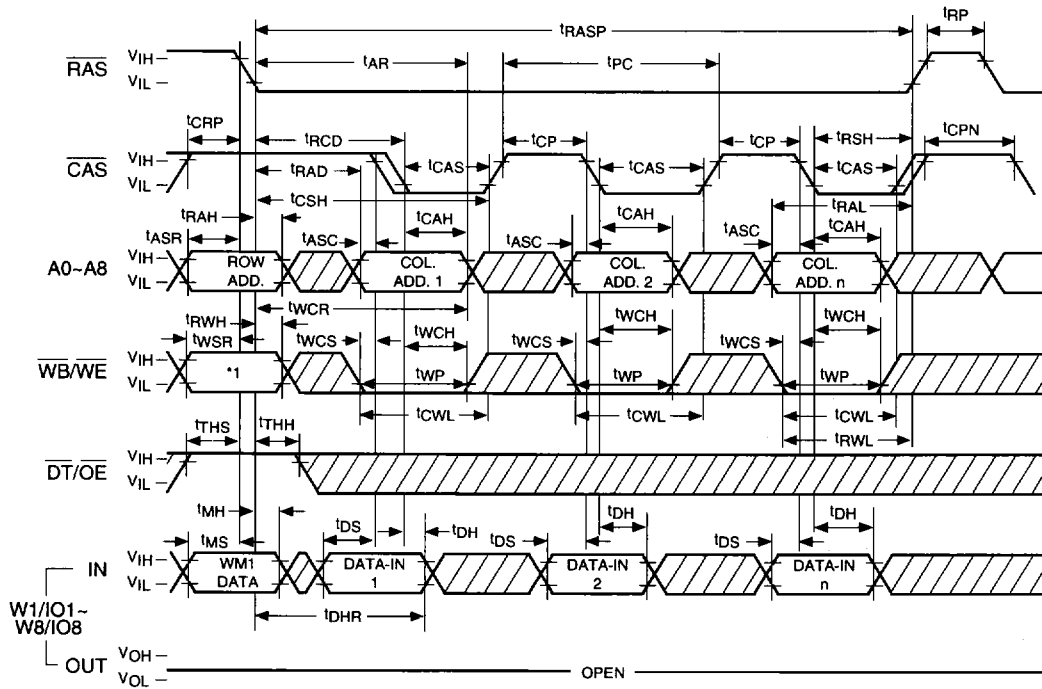

3

*1 WB/WE	W1/IO1~W8/IO8	Cycle
0	WM1 data	Write per bit
1	Don't Care	Normal Write

 : "H" OR "L"

WM1 data: 0: Write Disable  
1: Write Enable



**RAS Only Refresh Cycle**

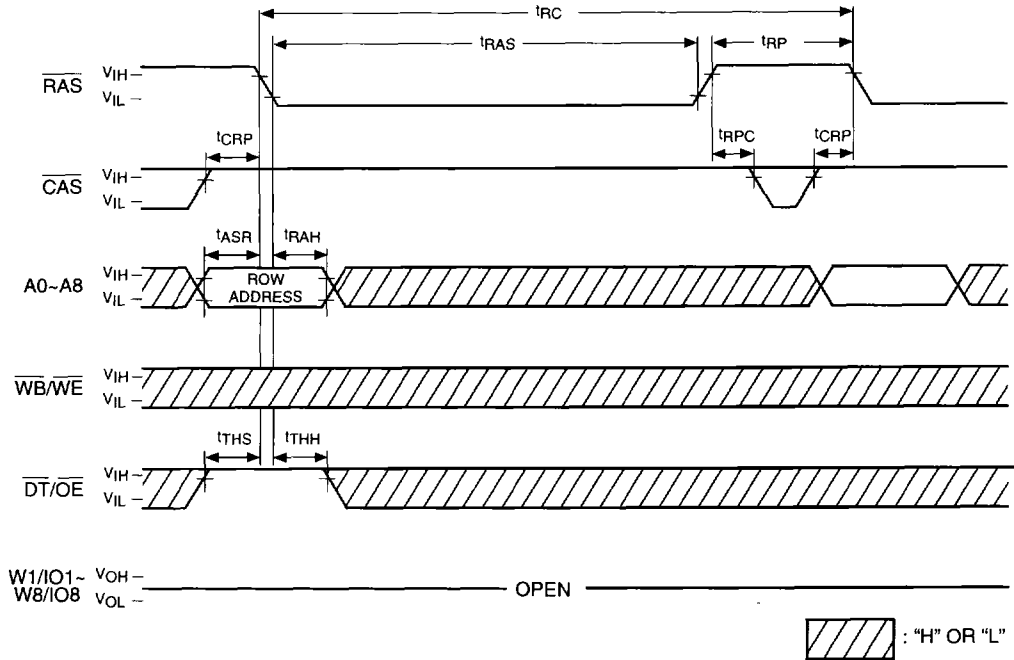

3

**CAS before RAS Refresh Cycle**

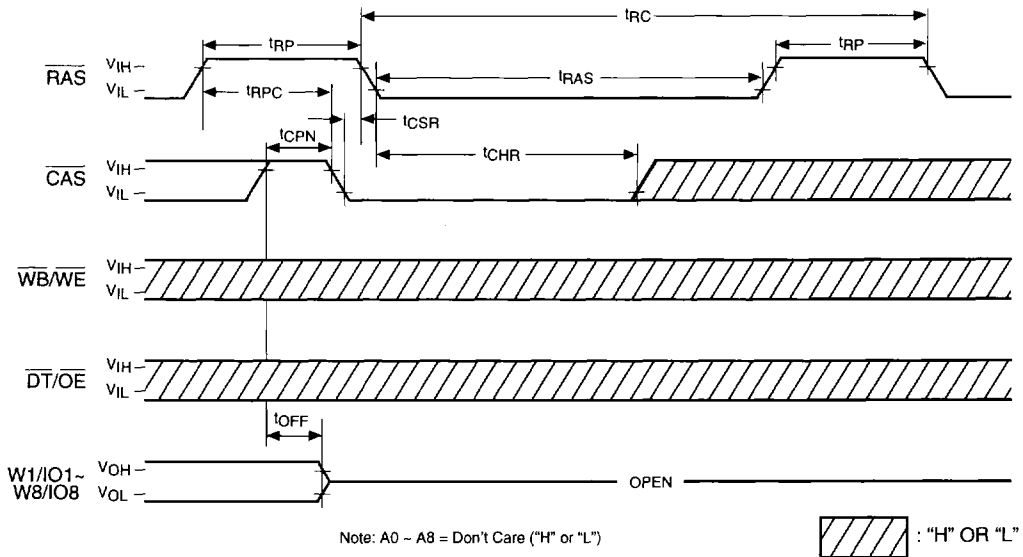



Read Transfer Cycle (Previous Transfer is Write Transfer Cycle)

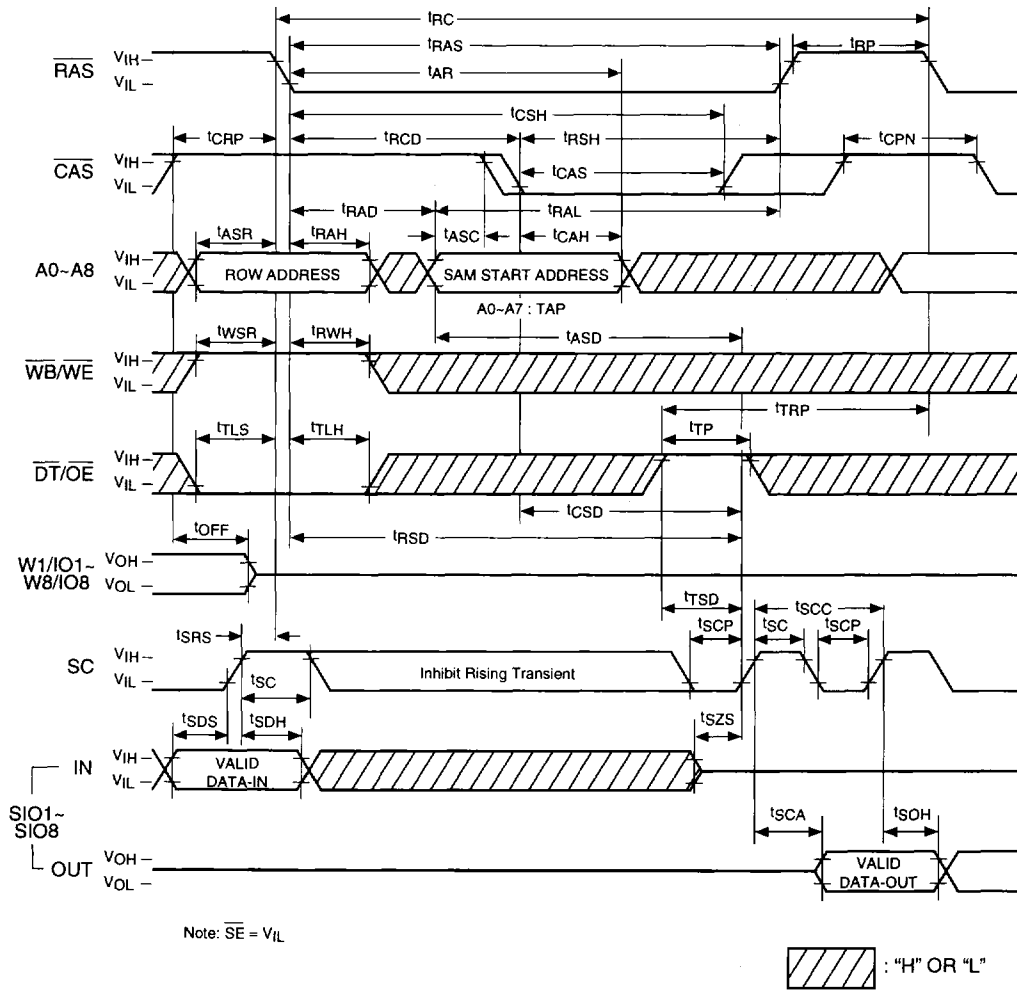

3

**Real Time Read Transfer Cycle**

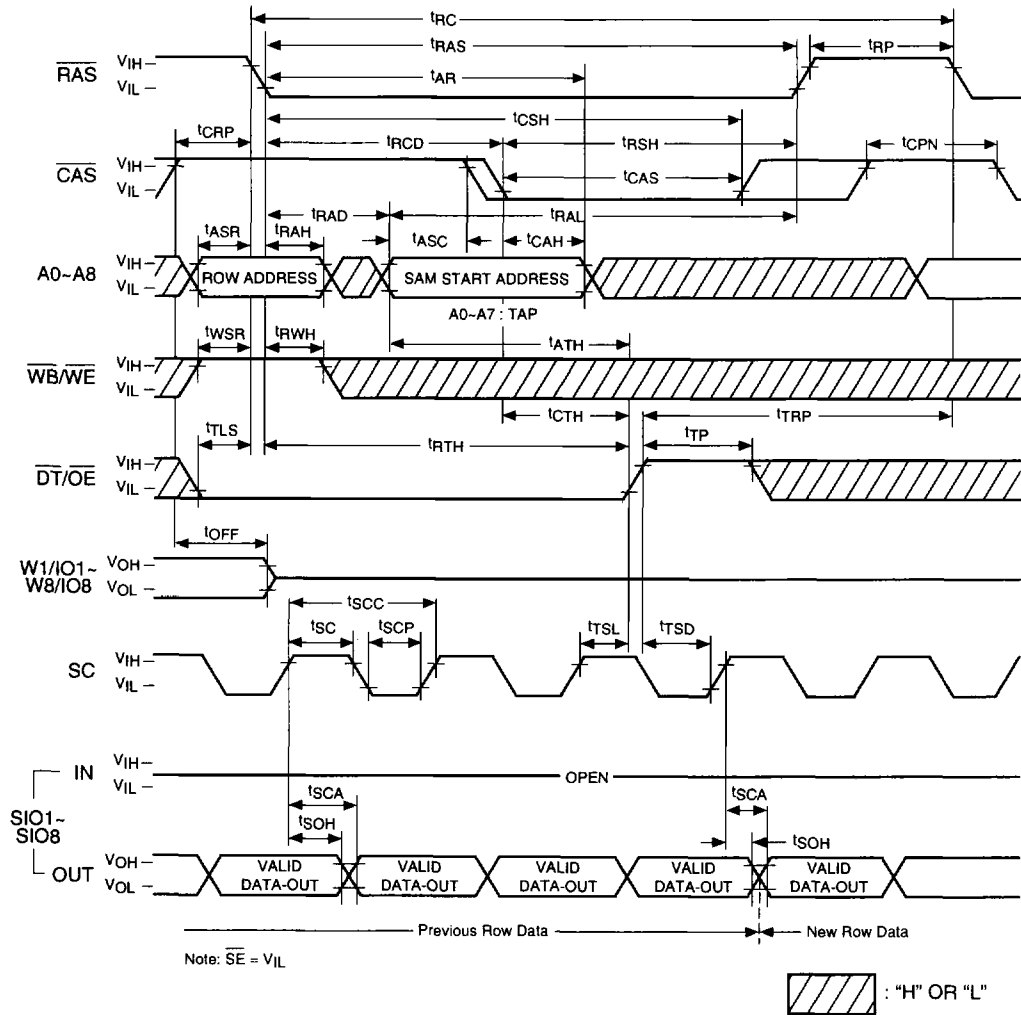

Pseudo Write Transfer Cycle

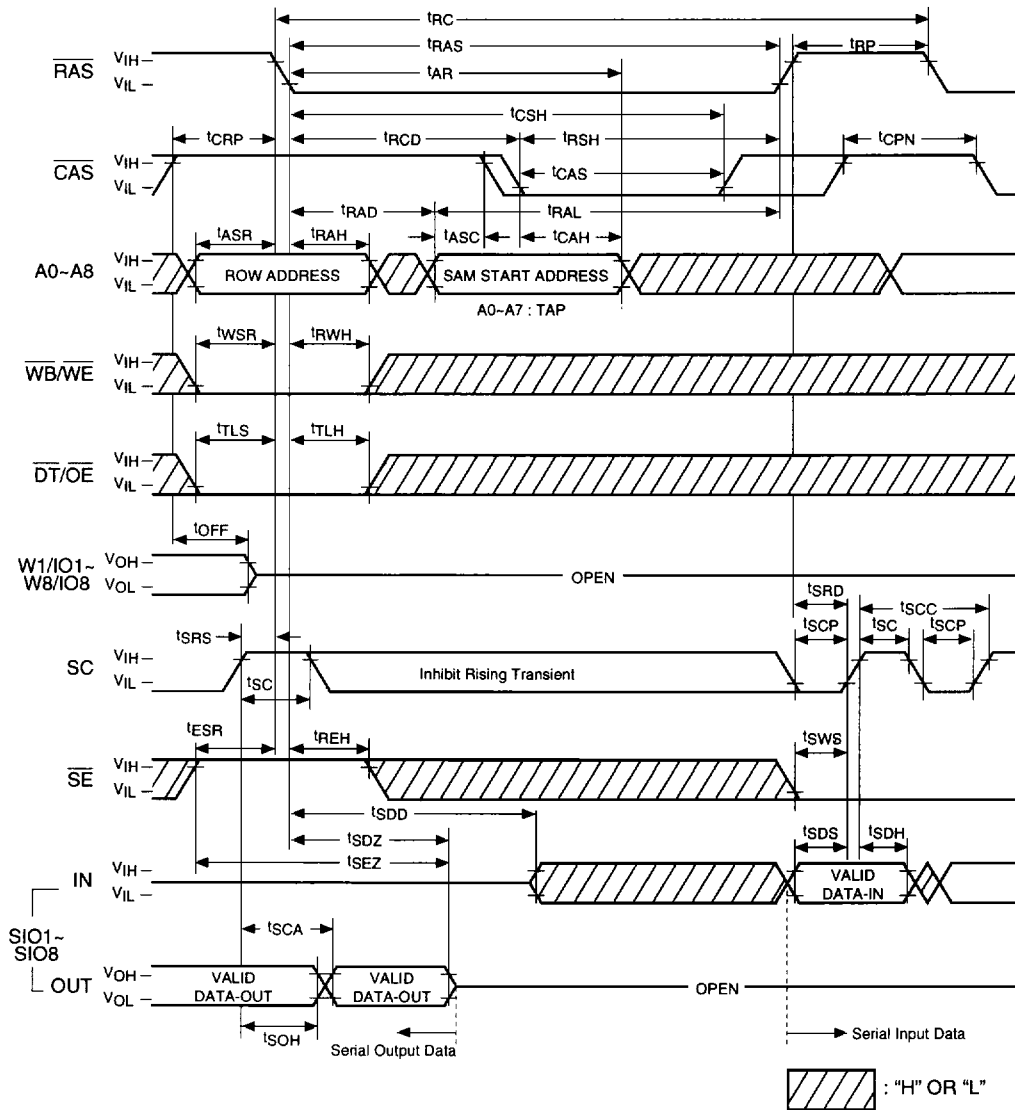

3

Write Transfer Cycle

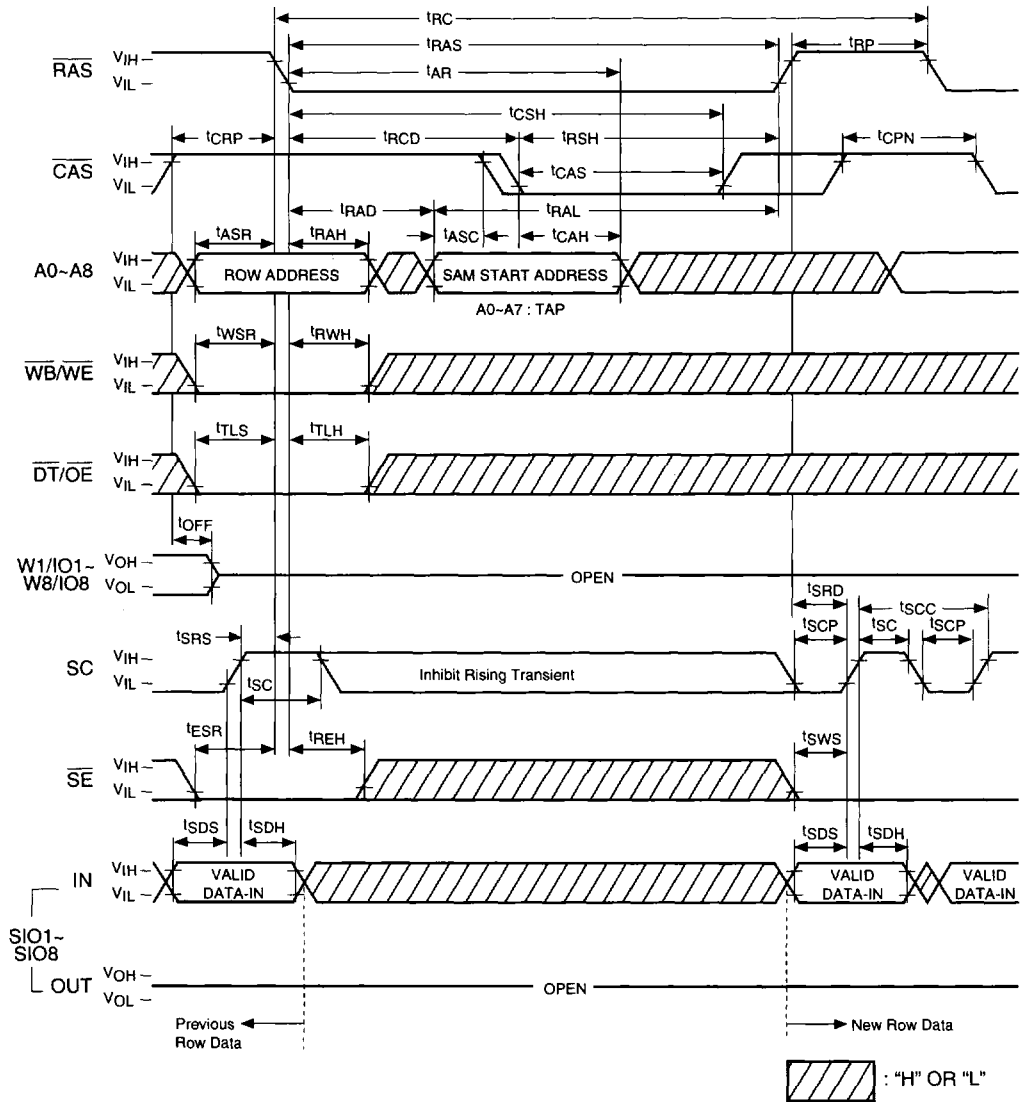

Serial Read Cycle ( $\overline{SE} = V_{IL}$ )

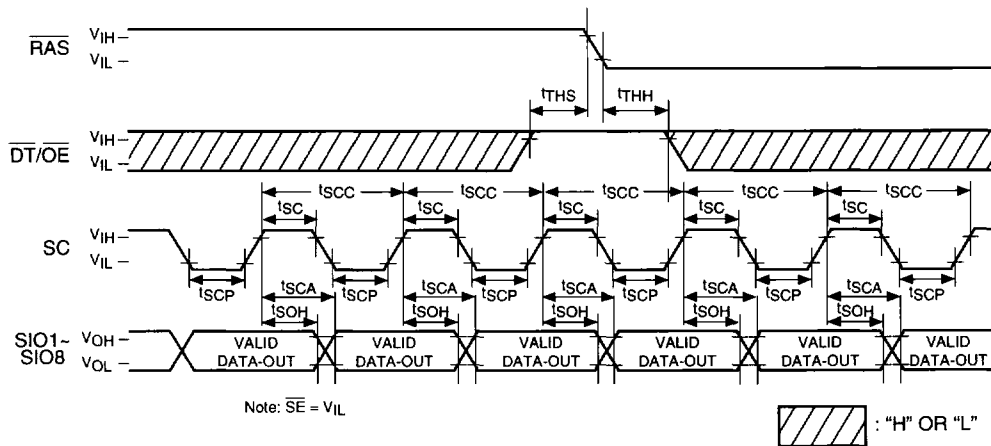

3

Serial Read Cycle ( $\overline{SE}$  Controlled Outputs)

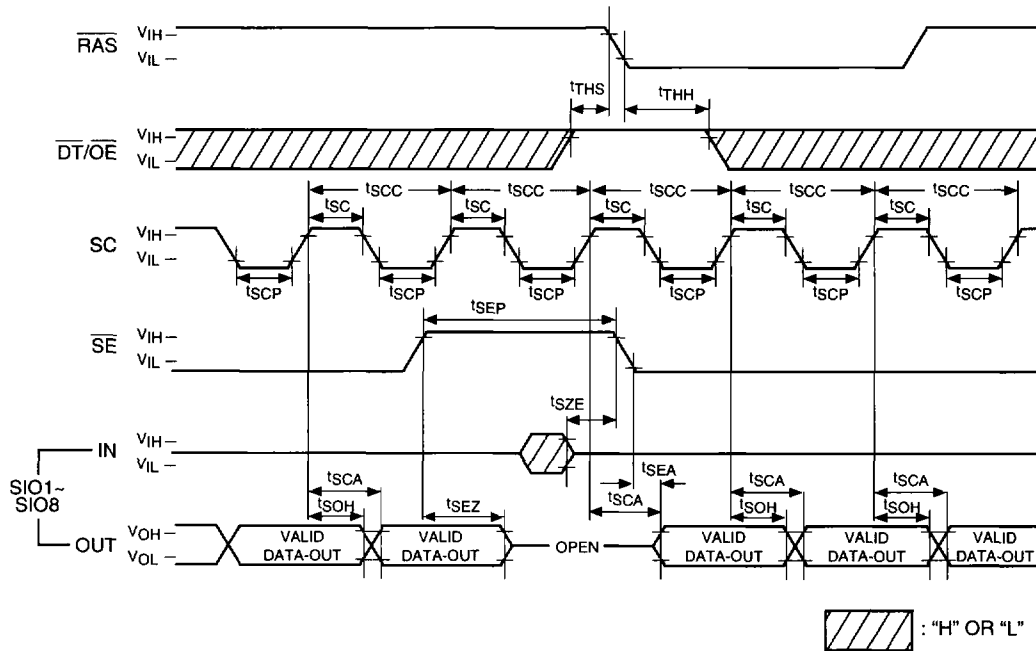

**Serial Write Cycle ( $\overline{SE} = V_{IL}$ )**

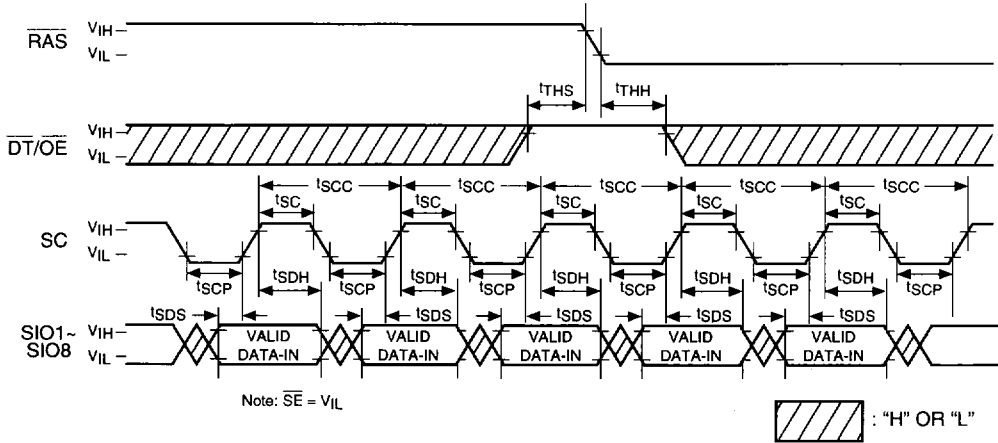

**Serial Write Cycle ( $\overline{SE}$  Controlled Inputs)**

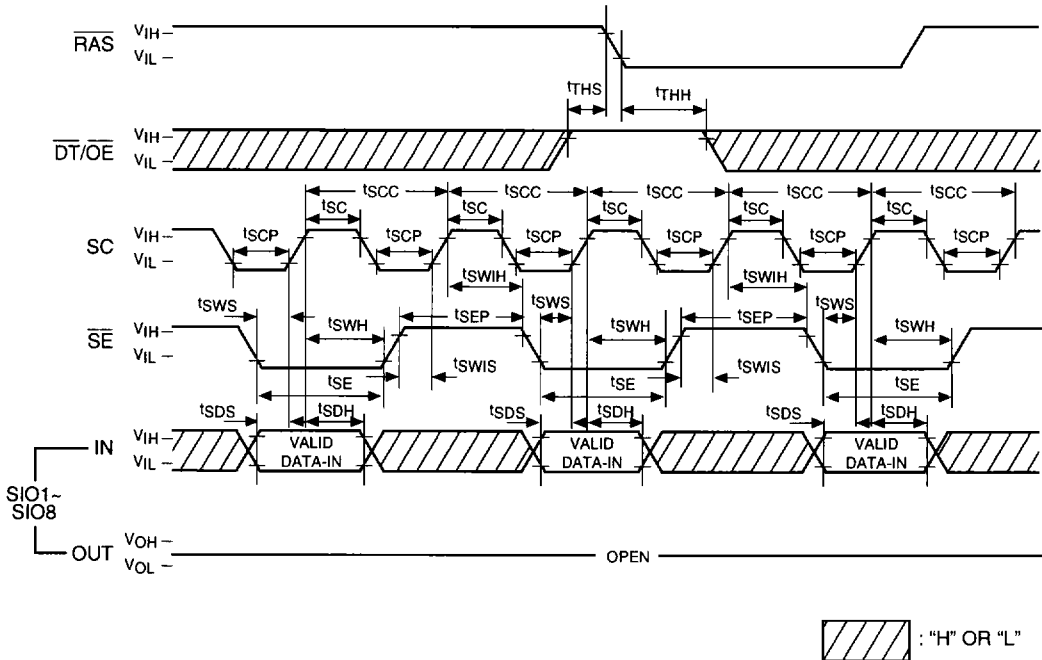

## Pin Functions

### Address Inputs: A0–A8

The 17 address bits required to decode 8 bits of the 1,048,576 cell locations within the dynamic RAM memory array of the V52C8126 are multiplexed onto 9 address input pins (A<sub>0</sub>–A<sub>8</sub>). Nine row address bits are latched on the falling edge of the row address strobe ( $\overline{\text{RAS}}$ ) and the following eight column address bits are latched on the falling edge of the column address strobe ( $\overline{\text{CAS}}$ ).

### Row Address Strobe: $\overline{\text{RAS}}$

A random access cycle or a data transfer cycle begins at the falling edge of  $\overline{\text{RAS}}$ .  $\overline{\text{RAS}}$  is the control input that latches the row address bits and the states of  $\overline{\text{CAS}}$ ,  $\overline{\text{DT/OE}}$ ,  $\overline{\text{WB/WE}}$  and  $\overline{\text{SE}}$  to invoke the various random access and data transfer operating modes shown in Table 2.  $\overline{\text{RAS}}$  has minimum and maximum pulse widths and a minimum precharge requirement which must be maintained for proper device operation and data integrity. The RAM port is placed in standby mode when the  $\overline{\text{RAS}}$  control is held "high".

### Column Address Strobe: $\overline{\text{CAS}}$

$\overline{\text{CAS}}$  is the control input that latches the column address bits.  $\overline{\text{CAS}}$  has minimum and maximum pulse widths and a minimum precharge requirement which must be maintained for proper device operation and data integrity.  $\overline{\text{CAS}}$  also acts as an output enable for the output buffers on the RAM port.

### Data Transfer/Output Enable: $\overline{\text{DT/OE}}$

The  $\overline{\text{DT/OE}}$  input is a multifunction pin. When  $\overline{\text{DT/OE}}$  is "high" at the falling edge of  $\overline{\text{RAS}}$ , RAM port operations are performed and  $\overline{\text{DT/OE}}$  is used as an output enable control. When the  $\overline{\text{DT/OE}}$  is "low" at the falling edge of  $\overline{\text{RAS}}$ , a data transfer operation is started between the RAM port and the SAM port.

### Write Per Bit/Write Enable: $\overline{\text{WB/WE}}$

The  $\overline{\text{WB/WE}}$  input is also a multifunction pin. When  $\overline{\text{WB/WE}}$  is "high" at the falling edge of  $\overline{\text{RAS}}$ , during RAM port operations, it is used to write data into the memory array in the same manner as a standard DRAM. When  $\overline{\text{WB/WE}}$  is "low" at the falling edge of  $\overline{\text{RAS}}$ , during RAM port operations, the write-per-bit function is enabled. The  $\overline{\text{WB/WE}}$  input also determines the direction of data transfer between the RAM array and the serial register (SAM).

When  $\overline{\text{WB/WE}}$  is "high" at the falling edge of  $\overline{\text{RAS}}$ , the data is transferred from RAM to SAM (read transfer). When  $\overline{\text{WB/WE}}$  is "low" at the falling edge of  $\overline{\text{RAS}}$ , the data is transferred from SAM to RAM (write transfer).

### Write Mask Data/Data Input and Output:

#### $W_1/\text{IO}_1$ – $W_8/\text{IO}_8$

When the write-per-bit function is enabled, the mask data on the  $W_i/\text{IO}_i$  pins is latched into the write mask register (WM1) at the falling edge of  $\overline{\text{RAS}}$ . Data is written into the DRAM on data lines where the write-mask data is a logic "1". Writing is inhibited on data lines where the write-mask data is a logic "0". The write-mask data is valid for only one cycle. Data is written into the RAM port during a write or read-modify-write cycle. The input data is latched at the falling edge of either  $\overline{\text{CAS}}$  or  $\overline{\text{WB/WE}}$ , whichever occurs late. During an early-write cycle, the outputs are in the high-impedance state. Data is read out of the RAM port during a read or read-modify-write cycle. The output data becomes valid on the  $W_i/\text{IO}_i$  pins after the specified access times from  $\overline{\text{RAS}}$ ,  $\overline{\text{CAS}}$ ,  $\overline{\text{DT/OE}}$  and column address are satisfied and will remain valid as long as  $\overline{\text{CAS}}$  and  $\overline{\text{DT/OE}}$  are kept "low". The outputs will return to the high-impedance state at the rising edge of either  $\overline{\text{CAS}}$  or  $\overline{\text{DT/OE}}$ , whichever occurs first.

### Serial Clock: SC

All operations of the SAM port are synchronized with the serial clock SC. Data is shifted in or out of the SAM registers at the rising edge of SC. In a serial read, the output data becomes valid on the SIO pins after the maximum specified serial access time  $t_{\text{SCA}}$  from the rising edge of SC. The serial clock SC also increments the 8-bits serial pointer which is used to select the SAM address. The pointer address is incremented in a wrap-around mode to select sequential locations after the starting location which is determined by the column address in the normal transfer cycle. When the pointer reaches the most significant address location (decimal 255), the next SC clock will place it at the least significant address location (decimal 0). The serial clock SC must be held at a constant  $V_{\text{IH}}$  or  $V_{\text{IL}}$  level during read/pseudo write/write transfer operations and should not be clocked while the SAM port is in the standby mode, to prevent the SAM pointer from being incremented.

3

**Serial Enable:  $\overline{SE}$**

The  $\overline{SE}$  input is used to enable serial access operation. In a serial read cycle,  $\overline{SE}$  is used as an output control. In a serial write cycle,  $\overline{SE}$  is used as a write enable control. When  $\overline{SE}$  is "high", serial access is disabled, however, the serial address pointer location is still incremented when SC is clocked even when  $\overline{SE}$  is "high".

**Serial Input/Output: SIO1-SIO8**

Serial input and output share common I/O pins. Serial input or output mode is determined by the most recent read, write or pseudo write transfer cycle. When a read transfer cycle is performed, the SAM port is in the output mode. When a write or pseudo write transfer cycle is performed, the SAM port is switched from output mode to input mode. During the subsequent write transfer cycle, the SAM remains in the input mode.

**Operation Mode**

The RAM port and data transfer operating of the V52C8126 are determined by the state of  $\overline{CAS}$ ,  $\overline{DT/OE}$ ,  $\overline{WB/WE}$ , and  $\overline{SE}$  at the falling edge of  $\overline{RAS}$ . The Table 1 and Table 2 show the operation truth table and the functional truth table for a listing of all available RAM port and transfer operations, respectively.

**Table 1. Operation Truth Table**

$\overline{RAS}$ Falling Edge $\downarrow$				Function
$\overline{CAS}$	$\overline{DT/OE}$	$\overline{WB/WE}$	$\overline{SE}$	
0	•	•	•	$\overline{CAS}$ -before- $\overline{RAS}$ Refresh
1	0	0	0	Write Transfer
1	0	0	1	Pseudo Write Transfer
1	0	1	•	Read Transfer
1	1	0	•	Read/Write per Bit
1	1	1	•	Read/Write

**Table 2. Functional Truth Table**

Function	$\overline{RAS}$ $\downarrow$				Address		W/O		Write Mask WM1
	$\overline{CAS}$	$\overline{DT/OE}$	$\overline{WB/WE}$	$\overline{SE}$	$\overline{RAS}$ $\downarrow$	$\overline{CAS}$ $\downarrow$	$\overline{RAS}$ $\downarrow$	$\overline{CAS}$ $\downarrow$ $\overline{WE}$ $\downarrow$	
$\overline{CAS}$ -before- $\overline{RAS}$ Refresh	0	•	•	•	•	-	•	-	-
Write Transfer	1	0	0	0	Row	TAP	•	•	-
Pseudo Write Transfer	1	0	0	1	Row	TAP	•	•	-
Read Transfer	1	0	1	•	Row	TAP	•	•	-
Write per Bit	1	1	0	•	Row	Column	WM1	DIN	Load use
Read/Write	1	1	1	•	Row	Column	•	DIN	-

Note : • = "0" or "1", TAP = SAM Start Address, - = not used.

**RAM Port Operation**

**Fast Page Mode Cycle**

Fast page mode allows data to be transferred into or out of multiple column locations of the same row by performing multiple  $\overline{\text{CAS}}$  cycles during a single active  $\overline{\text{RAS}}$  cycle. During a fast page cycle, the  $\overline{\text{RAS}}$  signal may be maintained active for a period up to 100  $\mu\text{s}$ . For the initial fast page mode access, the output data is valid after the specified access times from  $\overline{\text{RAS}}$ ,  $\overline{\text{CAS}}$ , column address and  $\overline{\text{DT}}/\overline{\text{OE}}$ . For all subsequent fast page mode read operations, the output data is valid after the specified access times from  $\overline{\text{CAS}}$ , column address and  $\overline{\text{DT}}/\overline{\text{OE}}$ . When the write-per-bit function is enabled, the mask data latched at the falling edge of  $\overline{\text{RAS}}$  is maintained throughout the fast page mode write or read-modify-write cycle.

**$\overline{\text{RAS}}$ -Only Refresh**

The data in the DRAM requires periodic refreshing to prevent data loss. Refreshing is accomplished by performing a memory cycle at each of the 512 rows in the DRAM array within the specified 8ms refresh period. Although any normal memory cycle will perform the refresh operation, this function is most easily accomplished with the " $\overline{\text{RAS}}$ -Only" cycle.

**$\overline{\text{CAS}}$ -before- $\overline{\text{RAS}}$  Refresh**

The V52C8126 also offers an internal-refresh function. When  $\overline{\text{CAS}}$  is held "low" for a specified period ( $t_{\text{CSR}}$ ) before  $\overline{\text{RAS}}$  goes "low", an internal refresh address counter and on-chip refresh control clock generators are enabled and an internal refresh operation takes place. When the refresh operation is completed, the internal refresh address counter is automatically incremented in preparation for the next  $\overline{\text{CAS}}$ -before- $\overline{\text{RAS}}$  cycle. For successive  $\overline{\text{CAS}}$ -before- $\overline{\text{RAS}}$  refresh cycles,  $\overline{\text{CAS}}$  can remain "low" while cycling  $\overline{\text{RAS}}$ .

**Hidden Refresh**

A hidden refresh is a  $\overline{\text{CAS}}$ -before- $\overline{\text{RAS}}$  refresh performed by holding  $\overline{\text{CAS}}$  "low" from a previous read cycle. This allows for the output data from the previous memory cycle to remain valid while performing a refresh. The internal refresh address counter provides the address and the refresh is accomplished by cycling  $\overline{\text{RAS}}$  after the specified  $\overline{\text{RAS}}$ -precharge period (refer to Figure 1.)

**Write-Per-Bit Function**

The write-per-bit function selectively controls the internal write-enable circuits of the RAM port. When  $\overline{\text{WB}}/\overline{\text{WE}}$  is held "low" at the falling edge of  $\overline{\text{RAS}}$ , during a random access operation, the write-mask is enabled. At the same time, the mask data on the  $\text{W}_i/\text{IO}_i$  pins is latched into the write-mask register (WM1). When a "0" is sensed on any of the  $\text{W}_i/\text{IO}_i$  pins, their corresponding write circuits are disabled and new data will not be written. When an "1" is sensed on any of the  $\text{W}_i/\text{IO}_i$  pins, their corresponding write circuits will remain enabled so that new data is written. The truth table of the write-per-bit function is shown in Table 3.

3

At the falling edge of $\overline{\text{RAS}}$				Function
$\overline{\text{CAS}}$	$\overline{\text{DT}}/\overline{\text{OE}}$	$\overline{\text{WB}}/\overline{\text{WE}}$	$\text{W}_i/\text{IO}_i$ ( $i = 1-8$ )	
H	H	H	•	Write Enable
H	H	L	1	Write Enable
H	H	L	0	Write Mask

**Table 3. Truth Table for Write-Per-Bit Function**

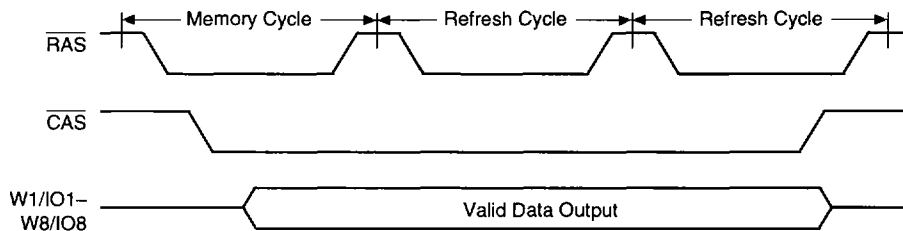

**Figure 1. Hidden Refresh Cycle**

An example of the write-per-bit function illustrating its application to displays is shown in Figures 2 and 3.

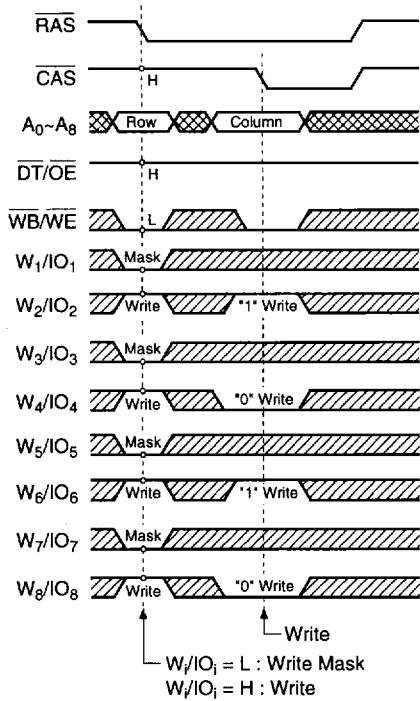

Figure 2. Write-per-bit timing cycle

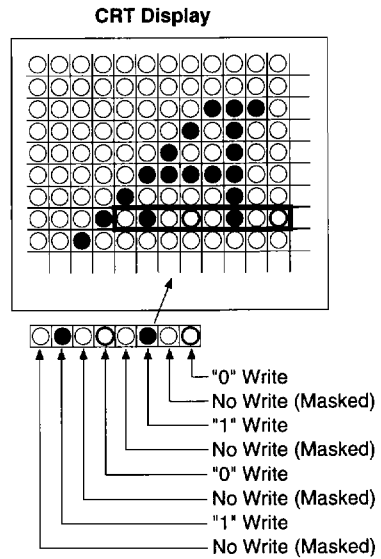

Figure 3. Corresponding bit-map

**SAM Port Operation**

The V52C8126 is provided with a 256 words by 8 bits serial access memory (SAM).

High speed serial read or write operations can be performed through the SAM port independent of the RAM port operations, except during read/write/pseudo-write transfer cycles. The preceding transfer operation determines the direction of data flow through the SAM port. If the preceding transfer operation is a read transfer, the SAM port is in the output mode. If the preceding transfer operation is a write or pseudo write transfer, the SAM port is in the input mode. The pseudo write transfer operation only switches the SAM port from output mode to

input mode; data is not transferred from SAM to RAM.

Serial data can be read out of the SAM port after a read transfer (RAM → SAM) has been performed. The data is shifted out of the SAM port starting at any of the 256 bits locations. The TAP location corresponds to the column address selected at the falling edge of  $\overline{\text{CAS}}$  during the read transfer cycle. The SAM registers are configured as circular data registers. The data is shifted out sequentially starting from the selected tap location to the most significant bit, and then wraps around to the least significant bit, as illustrated below.

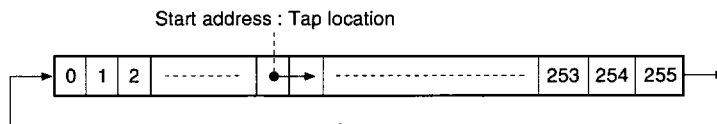

Subsequent real-time read transfer may be performed on-the-fly as many times as desired, within the refresh constraints of the DRAM array. Simultaneous serial read operation can be performed with some timing restrictions. A pseudo write transfer cycle is performed to change the SAM port from output mode to input mode, in order to write data into the serial registers through the SAM

port. A write transfer cycle must be used subsequently to load the SAM data into the RAM row selected by the row address at the falling edge of  $\overline{RAS}$ . The starting location in the SAM registers for the next serial write is selected by the column address at the falling edge of  $\overline{CAS}$ . The truth table for single register mode SAM operation is shown in Table 4.

SAM Port Operation	$\overline{DT}/\overline{OE}$ at the falling edge of $\overline{RAS}$	SC	$\overline{SE}$	Function	Preceded by a
Serial Output Mode	H		L	Enable Serial Read	Read Transfer
			H	Disable Serial Read	
Serial Input Mode	H		L	Enable Serial Write	Write Transfer
			H	Disable Serial Write	
Serial Input Mode	H		L	Enable Serial Write	Pseudo Write Transfer
			H	Disable Serial Write	

Table 4. Truth Table for SAM Port Operation

3

**Refresh**

The SAM data registers are static flip-flop, therefore a refresh is not required.

**Data Transfer Operation**

The V52C8126 features the internal bidirectional data transfer capability between RAM and the SAM, as shown in Figure 4. During a normal transfer, 256 words by 8 bits of data can be loaded from RAM to SAM (Read Transfer) or from SAM to RAM (Write Transfer).

As shown in Table 5, the V52C8126 supports three types of transfer operations: Read transfer, write transfer and pseudo write transfer. Data transfer operations between RAM and SAM are invoked by holding the  $\overline{DT}/\overline{OE}$  signal "low" at the falling edge of  $\overline{RAS}$ . The type of data transfer operation is determined by the state of  $\overline{CAS}$ ,  $\overline{WB}/\overline{WE}$  and  $\overline{SE}$  latched at the falling edge of  $\overline{RAS}$ . During data transfer operations, the SAM port is switched from input to output mode (Read Transfer) or output to input mode (Write Transfer/Pseudo Write Transfer). During a data transfer cycle, the row address  $A_0-A_8$  selects one of the 512 rows of the memory array to or from which data will be transferred, and the column address  $A_0-A_7$  selects one of the tap locations in the serial register. The selected tap location is the start position in the SAM port from which the first serial data will be read out during the subsequent serial read cycle or the start position in the SAM port into which the first serial data will be written during the subsequent serial write cycle.

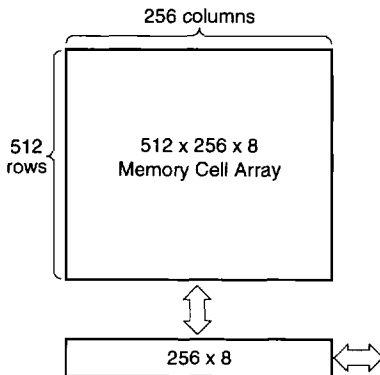

Figure 4. Data Transfer

At the falling edge of $\overline{RAS}$				Transfer Mode	Transfer Direction	Transfer Bit	SAM Port Mode
$\overline{CAS}$	$\overline{DT/OE}$	$\overline{WB/WE}$	SE				
H	L	H	•	Read Transfer	RAM → SAM	256 x 8	Input → Output
H	L	L	L	Write Transfer	SAM → RAM	256 x 8	Output → Input
H	L	L	H	Pseudo Write Transfer	—	—	Output → Input

Note: • = "H" or "L"

Table 5. Transfer Modes

**Read Transfer Cycle**

A read transfer cycle consists of loading a selected row of data from the RAM array into the SAM register. A read transfer is invoked by holding  $\overline{CAS}$  "high",  $\overline{DT/OE}$  "low" and  $\overline{WB/WE}$  "high" at the falling edge of  $\overline{RAS}$ . The row address selected at the falling edge of  $\overline{RAS}$  determines the RAM row to be transferred into the SAM. The transfer cycle is completed at the rising edge of  $\overline{DT/OE}$ . When the transfer is completed, the SAM port is set into the output mode. In a read/real time read transfer cycle, the transfer of a new row of data is completed at the rising edge of  $\overline{DT/OE}$  and this data becomes valid on the SIO lines after the specified access time

( $t_{SCA}$ ) from the rising edge of the subsequent serial clock (SC) cycle. The start address of the serial pointer of the SAM is determined by the column address selected at the falling edge of  $\overline{CAS}$ .

Figure 5 shows the operation block diagram for the read transfer operation.

In a read transfer cycle (which is preceded by a write transfer cycle), the SC clock must be held at a constant  $V_{IL}$  or  $V_{IH}$ , after the SC high time has been satisfied. A rising edge of the SC clock must not occur until after the specified delay ( $t_{TSD}$ ) from the rising edge of  $\overline{DT/OE}$ , as shown in Figure 6.

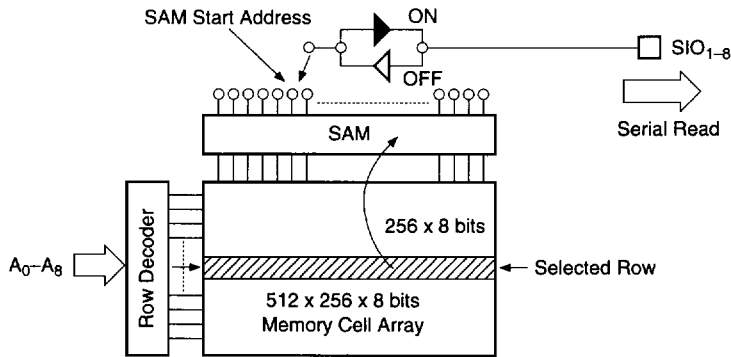

Figure 5. Block Diagram for Read Transfer Operation

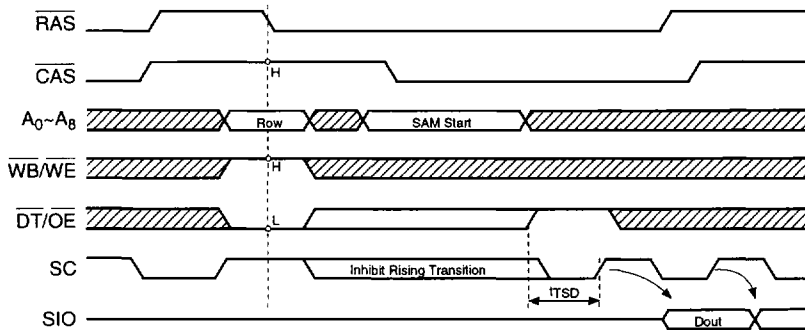

Figure 6. Read Transfer Timing

In a real time read transfer cycle (which is preceded by another read transfer cycle), the previous row data appears on the SIO lines until the  $\overline{DT/OE}$  signal goes "high" and the serial access time ( $t_{SCA}$ ) for the following serial clock is satisfied. This feature allows for the first bit of the new row of data to appear on the serial output as soon as the last bit of the previous row has been strobed without any timing loss. To make this continuous data flow possible, the rising edge of  $\overline{DT/OE}$  must be synchronized with  $\overline{RAS}$ ,  $\overline{CAS}$  and the subsequent rising edge of SC ( $t_{RTH}$ ,  $t_{CTH}$ , and  $t_{TSL}/t_{TSD}$  must be satisfied), as shown in Figure 7.

The timing restrictions  $t_{TSL}/t_{TSD}$  are 5ns min/15ns min.

**Write Transfer Cycle**

A write transfer cycle consists of loading the contents of the SAM register into a selected row of the RAM array. If the SAM data to be transferred must first be loaded through the SAM port, a pseudo write transfer operation must precede the write transfer cycles. However, if the SAM port data to be transferred into the RAM was previously loaded into the SAM via a read transfer, the SAM to RAM transfer can be executed simply by performing a write transfer directly. A write transfer is invoked by holding  $\overline{CAS}$  "high",  $\overline{DT/OE}$  "low",  $\overline{WB/WE}$  "low" and  $\overline{SE}$  "low" at the falling edge of  $\overline{RAS}$ . Figures 8 and 9 show the timing diagram and block diagram for write transfer operations, respectively.

3

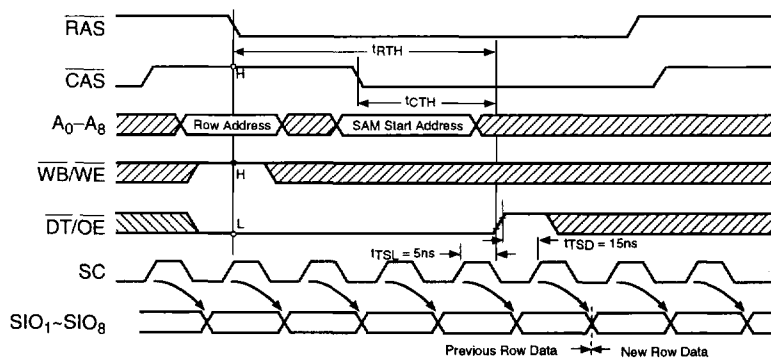

Figure 7. Real Time Read Transfer

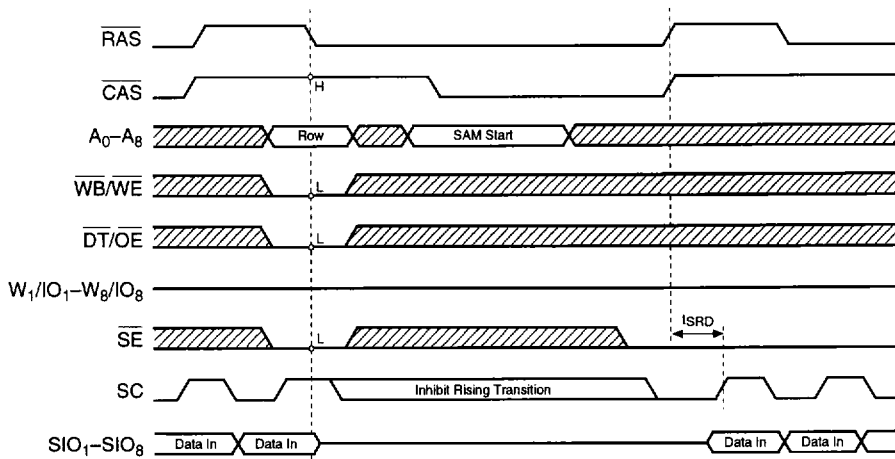

Figure 8. Write Transfer Timing

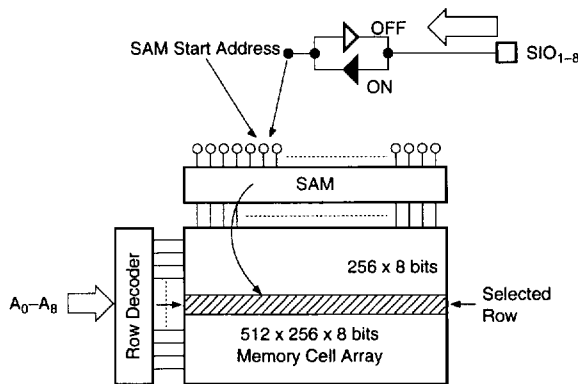

Figure 9. Block Diagram for Write Transfer Operation

The row address selected at the falling edge of  $\overline{RAS}$  determines the RAM row address into which the data will be transferred. The column address selected at the falling edge of  $\overline{CAS}$  determines the start address of the serial pointer of the SAM. After the write transfer is completed, the  $SIO$  lines are set in the input mode so that serial data synchronized with the  $SC$  clock can be loaded.

When consecutive write transfer operations are performed, new data must not be written into the serial register until the  $\overline{RAS}$  cycle of the preceding write transfer is completed. Consequently, the  $SC$  clock must be held at a constant  $V_{IL}$  or  $V_{IH}$  during the  $\overline{RAS}$  cycle. A rising edge of the  $SC$  clock is only allowed after the specified delay ( $t_{SRD}$ ) from the rising edge of  $\overline{RAS}$ , at which time a new row of data can be written in the serial register.

**Pseudo Write Transfer Cycle**

A pseudo write transfer cycle must be performed before loading data into the serial register after a read transfer operation has been executed. The only purpose of a pseudo write transfer is to change the SAM port mode from output mode to input mode (a data transfer from SAM to RAM does not occur). After the serial register is loaded with new data, a write transfer cycle must be performed to transfer the data from SAM to RAM. A pseudo write transfer is invoked by holding  $\overline{\text{CAS}}$  "high",  $\overline{\text{DT/OE}}$  "low",  $\overline{\text{WB/WE}}$  "low" and  $\overline{\text{SE}}$  "high" at the falling edge of  $\overline{\text{RAS}}$ . The timing conditions are the same as the one for the write transfer cycle except for the state of  $\overline{\text{SE}}$  at the falling edge of  $\overline{\text{RAS}}$ .

**Register Operation Sequence - Example**

Figure 10 illustrates an example of register operation sequence after device power-up and initialization. After power-up, a minimum of 8  $\overline{\text{RAS}}$  and 8 SC clock cycles must be performed to properly initialize the device. A read transfer is then performed and the column address latched at the falling edge of  $\overline{\text{CAS}}$  sets the SAM tap pointer location, which up to that point was in an undefined location. Subsequently, the pointer address is incremented by cycling the serial clock SC from the starting location to the last location in the register (address 255), and wraps around to the least significant address location. The SAM address is incremented as long as SC is clocked.

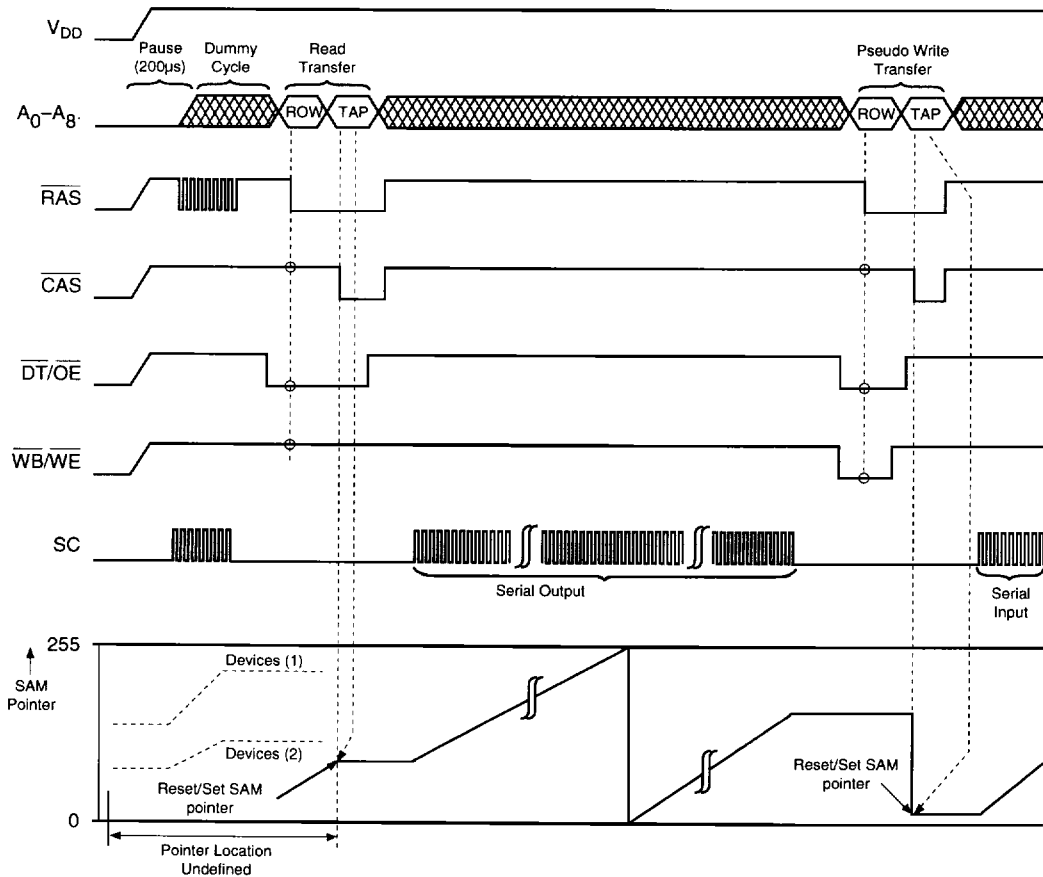
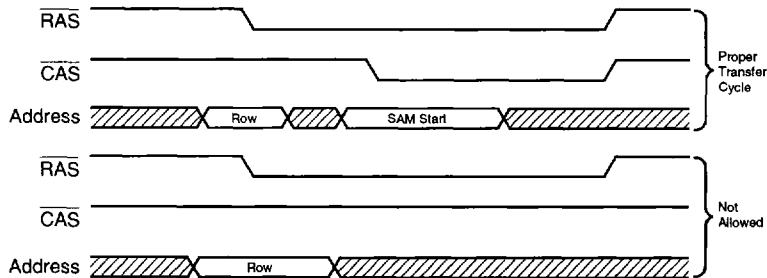

Figure 10. Example of SAM Register Operation Sequence

The next operation is a pseudo write transfer which switches the SAM port from output mode to input mode in preparation for write transfers. The column address latched at the falling edge of  $\overline{\text{CAS}}$  during the pseudo write transfer sets the serial register tap location. Serial data will be written into the SAM starting from this location.

**Transfer Operation Without  $\overline{\text{CAS}}$**

During all transfer cycles, the  $\overline{\text{CAS}}$  input clock must be cycled, so that the column addresses are latched at the falling edge of  $\overline{\text{CAS}}$ , to set the SAM tap location. If  $\overline{\text{CAS}}$  was maintained at a constant "high" level during a transfer cycle, the SAM pointer location would be undefined. Therefore, a transfer cycle with  $\overline{\text{CAS}}$  held "high" is not allowed (refer to the illustration below).



**Read Transfer Cycle After Read Transfer Cycle**

Another read transfer may be performed following the read transfer provided that a minimum delay of 30 ns from the rising edge of the first clock

SC is satisfied (refer to the illustration shown below).

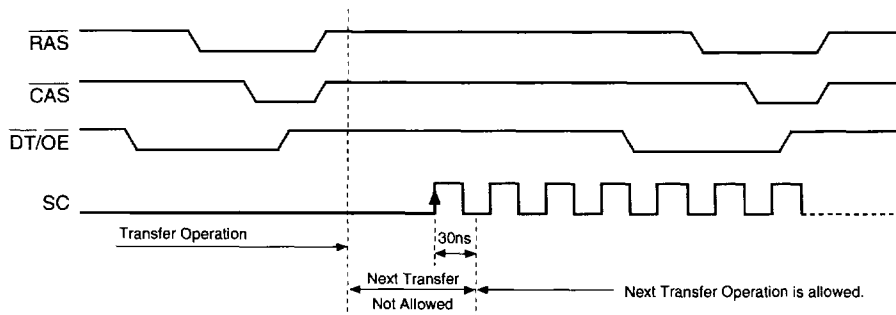

**Power-Up**

Power must be applied to the  $\overline{RAS}$  and  $\overline{DT/OE}$  input signals to pull them "high" before or at the same time as the  $V_{DD}$  supply is turned on. After power-up, a pause of 200  $\mu$ seconds minimum is required with  $\overline{RAS}$  and  $\overline{DT/OE}$  held "high". After the pause, a minimum of 8  $\overline{RAS}$  and 8 SC dummy cycles must be performed to stabilize the internal circuitry, before valid read, write or transfer operations can begin. During the initialization period, the  $\overline{DT/OE}$  signal must be held "high". If the internal refresh counter is used, a minimum 8  $\overline{CAS}$ -before- $\overline{RAS}$  initialization cycles are required instead of 8  $\overline{RAS}$  cycles.

**Initial State After Power-Up**

When power is achieved with  $\overline{RAS}$ ,  $\overline{CAS}$ ,  $\overline{DT/OE}$  and  $\overline{WB/WE}$  held "high", the internal state of the V52C8126 is automatically set as follows.

However, the initial state can not be guaranteed for various power-up conditions and input signal levels. Therefore, it is recommended that the initial state be set after the initialization of the device is performed (200  $\mu$ s pause followed by a minimum of 8  $\overline{RAS}$  cycles and 8 SC cycles) and before valid operations begin.

	State after power-up
SAM port	Input Mode
TAP pointer	Invalid
WM1 Register	Write Enable