

TYPES SN54H55, SN54L55, SN54LS55, SN74H55, SN74LS55 2-WIDE 4-INPUT AND-OR-INVERT GATES

REVISED DECEMBER 1983

- Package Options Include Both Plastic and Ceramic Chip Carriers in Addition to Plastic and Ceramic DIPs
- Dependable Texas Instruments Quality and Reliability

description

These devices contain 2-wide 4-input AND-OR-INVERT gates. The 'L55 and 'LS55 perform the Boolean function $Y = ABCD + EFGH$. The 'H55 is expandable and performs the Boolean function $Y = ABCD + EFGH + X$ with X = output of SN54H60/SN74H60 or SN54H62/SN74H62.

The SN54H55, SN54L55, and the SN54LS55 are characterized for operation over the full military temperature range of -55° to 125°C . The SN74H55 and SN74LS55 are characterized for operation from 0°C to 70°C .

logic diagrams

'H55, EXPANDABLE

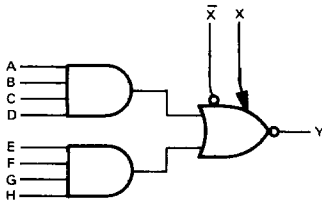

'L55, 'LS55

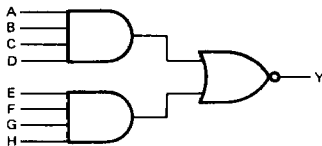

SN54H55 ... J PACKAGE
SN74H55 ... J OR N PACKAGE
(TOP VIEW)

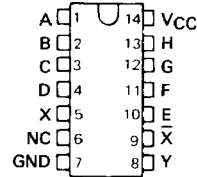

SN54H55 ... W PACKAGE
(TOP VIEW)

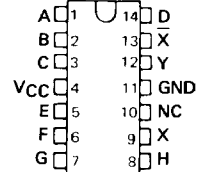

SN54L55 ... J PACKAGE
SN54LS55 ... J OR W PACKAGE
SN74LS55 ... D, J OR N PACKAGE
(TOP VIEW)

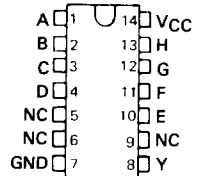

SN54LS55 ... FK PACKAGE
SN74LS55 ... FN PACKAGE
(TOP VIEW)

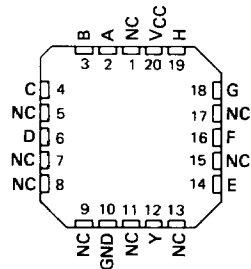

NC - No internal connection

3

TTL DEVICES

PRODUCTION DATA
This document contains information current as of publication date. Products conform to specifications per the terms of Texas Instruments standard warranty. Production processing does not necessarily include testing of all parameters.

TEXAS INSTRUMENTS
POST OFFICE BOX 225012 • DALLAS, TEXAS 75265

3-237

**TYPES SN54H55, SN54L55, SN54LS55,
SN74H55, SN74LS55
2-WIDE 4-INPUT AND-OR-INVERT GATES**

schematics

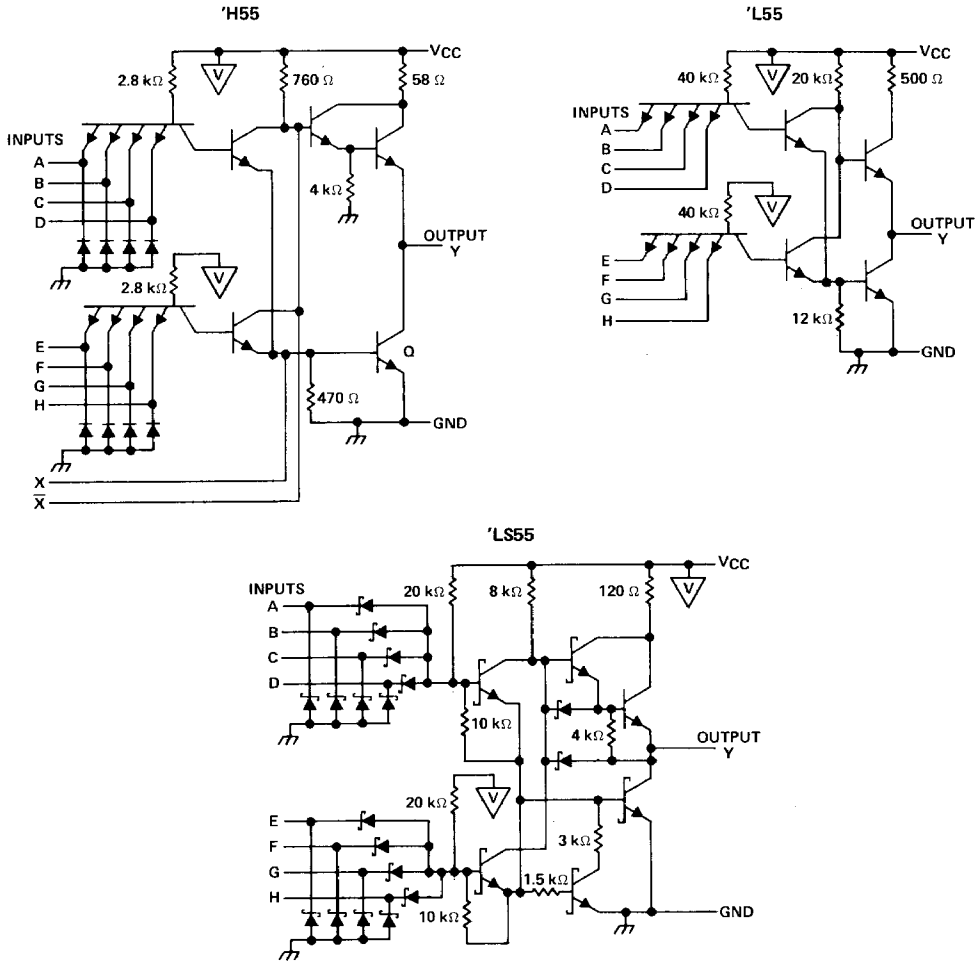

Resistor values shown are nominal.

absolute maximum ratings over operating free-air temperature range (unless otherwise noted)

Supply voltage, V _{CC} (see Note 1)	7 V
Input voltage: 'H55, 'L55	5.5 V
'LS55	7 V
Operating free-air temperature range: SN54'	-55°C to 125°C
SN74'	0°C to 70°C
Storage temperature range	-65°C to 150°C

NOTE 1: Voltage values are with respect to network ground terminal.

TYPES SN54H55, SN74H55
2-WIDE 4-INPUT AND-OR-INVERT GATES

recommended operating conditions

	SN54H55			SN74H55			UNIT
	MIN	NOM	MAX	MIN	NOM	MAX	
V _{CC} Supply voltage	4.5	5	5.5	4.75	5	5.25	V
V _{IH} High-level input voltage	2			2			V
V _{IL} Low-level input voltage			0.8			0.8	V
I _{OH} High-level output current			-0.5			-0.5	mA
I _{OL} Low-level output current			20			20	mA
T _A Operating free-air temperature	-55		125	0		70	°C

electrical characteristics over recommended operating free-air temperature range (unless otherwise noted)

PARAMETER	TEST CONDITIONS†	SN54H55		SN74H55		UNIT		
		MIN	TYP‡	MAX	MIN		TYP‡	MAX
V _{IK}	V _{CC} = MIN, I _I = -8 mA			-1.5		-1.5	V	
V _{OH}	V _{CC} = MIN, V _{IL} = 0.8 V, I _{OH} = -0.5 mA	2.4	3.4		2.4	3.4	V	
V _{OL}	V _{CC} = MIN, V _{IH} = 2 V, I _{OL} = 20 mA		0.2	0.4		0.2	0.4	V
I _I	V _{CC} = MAX, V _I = 5.5 V			1		1	mA	
I _{IH}	V _{CC} = MAX, V _{IH} = 2.4 V			50		50	μA	
I _{IL}	V _{CC} = MAX, V _{IL} = 0.4 V			-2		-2	mA	
I _{OS} §	V _{CC} = MAX	-40		-100	-40	-100	mA	
I _{CCH}	V _{CC} = MAX, V _I = 0 V		4.5	6.4		4.5	6.4	mA
I _{CCL}	V _{CC} = MAX, See Note 2		7.5	12		7.5	12	mA
I _X ▲	V _X = 1.4 V, I _X = 0, I _{OL} = 0			-5.85		-6.3	mA	
V _{BEI(Q)} ▲	I _X + I _X = 0.7 mA, R _X = 0, I _{OL} = 20 mA			1.1				
	I _X + I _X = 1.1 mA, R _X = 0, I _{OL} = 20 mA					1	V	
V _{OH} ▲	I _X = 0.32 mA, I _X = -0.32 mA, I _{OH} = -0.5 mA	2.4	3.4					
	I _X = 0.57 mA, I _X = -0.57 mA, I _{OH} = -0.5 mA				2.4	3.4	V	
V _{OL} ▲	I _X + I _X = 0.47 mA, R _X = 68 Ω, I _{OL} = 20 mA	0.2	0.4					
	I _X + I _X = 0.6 mA, R _X = 63 Ω, I _{OL} = 20 mA				0.2	0.4	V	

† For conditions shown as MIN or MAX, use the appropriate value specified under recommended operating conditions.

‡ All typical values are at V_{CC} = 5 V, T_A = 25°C.

§ Not more than one output should be shorted at a time.

▲ Using expander inputs, V_{CC} = MIN, T_A = MIN, except typical values.

NOTE 2: All inputs of one AND gate at 4.5 V, all others at GND.

switching characteristics, V_{CC} = 5 V, T_A = 25°C (see note 3)

PARAMETER	FROM (INPUT)	TO (OUTPUT)	TEST CONDITIONS	MIN	TYP	MAX	UNIT	
t _{PLH}	Any	Y	R _L = 280 Ω, C _L = 25 pF †		7	11	ns	
t _{PHL}					6.5	11	ns	
t _{PLH}			R _L = 280 Ω, C _L = 25 pF, C = 15 pF ‡			11.4		ns
t _{PHL}						7.7		ns

NOTE 3: See General Information Section for load circuits and voltage waveforms.

† Expander pins open.

‡ GND to X.

3

TTL DEVICES

TYPE SN54L55 2-WIDE 4-INPUT AND-OR-INVERT GATES

recommended operating conditions

	SN54L55			UNIT
	MIN	NOM	MAX	
V _{CC} Supply voltage	4.5	5	5.5	V
V _{IH} High-level input voltage	2			V
V _{IL} Low-level input voltage	0.7			V
I _{OH} High-level output current	-0.1			mA
I _{OL} Low-level output current	2			mA
T _A Operating free-air temperature	-55	125		°C

electrical characteristics over recommended operating free-air temperature range (unless otherwise noted)

PARAMETER	TEST CONDITIONS†			SN54L55			UNIT
	MIN	TYP‡	MAX	MIN	TYP‡	MAX	
V _{OH}	V _{CC} = MIN, V _{IL} = 0.7 V, I _{OH} = -0.1 mA	2.4	3.3				V
V _{OL}	V _{CC} = MIN, V _{IH} = 2 V, I _{OL} = 2 mA		0.15	0.33			V
I _I	V _{CC} = MAX, V _I = 5.5 V					0.1	mA
I _{IH}	V _{CC} = MAX, V _I = 2.4 V					10	μA
I _{IL}	V _{CC} = MAX, V _I = 0.3 V					-0.18	mA
I _{OS} §	V _{CC} = MAX			-3		-15	mA
I _{CCH}	V _{CC} = MAX, V _I = 0 V				0.22	0.4	mA
I _{CCL}	V _{CC} = MAX, See Note 2				0.38	0.65	mA

† For conditions shown as MIN or MAX, use the appropriate value specified under recommended operating conditions.

‡ All typical values are at V_{CC} = 5 V, T_A = 25° C.

§ Not more than one output should be shorted at a time.

NOTE 2: All inputs of one AND gate at 4.5 V, all others at GND.

switching characteristics, V_{CC} = 5 V, T_A = 25° C (see note 3)

PARAMETER	FROM (INPUT)	TO (OUTPUT)	TEST CONDITIONS	MIN	TYP	MAX	UNIT
t _{PLH}	Any	Y	R _L = 4 kΩ, C _L = 50 pF	50		90	ns
t _{PHL}				35		60	ns

NOTE 3: See General Information Section for load circuits and voltage waveforms.

3

TTL DEVICES

TYPES SN54LS55, SN74LS55 2-WIDE 4-INPUT AND-OR-INVERT GATES

recommended operating conditions

	SN54LS55			SN74LS55			UNIT
	MIN	NOM	MAX	MIN	NOM	MAX	
V _{CC} Supply voltage	4.5	5	5.5	4.75	5	5.25	V
V _{IH} High-level input voltage	2			2			V
V _{IL} Low-level input voltage	0.7			0.8			V
I _{OH} High-level output current	-0.4			-0.4			mA
I _{OL} Low-level output current	4			8			mA
T _A Operating free-air temperature	-55			125			°C

electrical characteristics over recommended operating free-air temperature range (unless otherwise noted)

PARAMETER	TEST CONDITIONS†	SN54LS55			SN74LS55			UNIT
		MIN	TYP‡	MAX	MIN	TYP‡	MAX	
V _{IK}	V _{CC} = MIN, I _I = -18 mA	-1.5			-1.5			V
V _{OH}	V _{CC} = MIN, V _{IL} = MAX, I _{OH} = -0.4 mA	2.5	3.4		2.7	3.4		V
V _{OL}	V _{CC} = MIN, V _{IH} = 2 V, I _{OL} = 4 mA	0.25		0.4	0.25		0.4	V
	V _{CC} = MIN, V _{IH} = 2 V, I _{OL} = 8 mA				0.35		0.5	
I _I	V _{CC} = MAX, V _I = 7 V	0.1			0.1			mA
I _{IH}	V _{CC} = MAX, V _I = 2.7 V	20			20			μA
I _{IL}	V _{CC} = MAX, V _I = 0.4 V	-0.4			-0.4			mA
I _{OS} §	V _{CC} = MAX	-20		-100	-20		-100	mA
I _{CC}	V _{CC} = MAX, V _I = 0 V	0.4		0.8	0.4		0.8	mA
I _{CCL}	V _{CC} = MAX, See Note 2	0.7		1.3	0.7		1.3	mA

† For conditions shown as MIN or MAX, use the appropriate value specified under recommended operating conditions.

‡ All typical values are at V_{CC} = 5 V, T_A = 25°C.

§ Not more than one output should be shorted at a time, and the duration of the short-circuit should not exceed one second.

NOTE 2: All outputs of one AND gate at 4.5 V, all others at GND.

switching characteristics, V_{CC} = 5 V, T_A = 25°C (see note 3)

PARAMETER	FROM (INPUT)	TO (OUTPUT)	TEST CONDITIONS	MIN	TYP	MAX	UNIT
t _{PLH}	Any	Y	R _L = 2 kΩ, C _L = 15 pF	12		20	ns
t _{PHL}				12.5		20	ns

NOTE 3: See General Information Section for load circuits and voltage waveforms.

3

TTL DEVICES