



Applicable sockets:
SO-1057-8912



Application Notes:
101
102
103E
007

• All welded construction

• Contact arrangement 3 PDT configuration in one inch cube

• Qualified to MIL-PRF-83536

PRINCIPLE TECHNICAL CHARACTERISTICS

• Contacts rated at	28 Vdc; 115 Vac, 400 Hz, 1Ø and 115/200 Vac, 400 Hz 3Ø
• Weight	0.188 lb max
• Dimensions	1.01in x 1.01in x 1.00in
• Hermetically sealed, corrosion resistant metal can. Detail specifications and ordering data appear on the following pages.	

CONTACT ELECTRICAL CHARACTERISTICS

Contact rating per pole and load type [1]	Load current in Amps			
	@28 Vdc	@115 Vac 400 Hz	@115/200 Vac, 400 Hz, 3Ø	@115/200 Vac, 60 Hz, 3Ø [9]
Resistive [2]	25	25	25	2.5
Inductive [3]	12	15	15	2.5
Motor	10	10	10	2
Lamp	5	5	5	1
Overload	40	80	80	N/A
Rupture	60	100	100	N/A
Circuit Breaker	-	-	-	
Compatible [10]				

AMERICAS.

Tel: +1 714-736-7599
<http://www.esterline.com/powersystems>

EUROPE.

Tel: +33 3 87 97 31 01
Fax: +33 3 87 97 96 86

ASIA

Tel: +852 2 191 3830
Fax: +852 2 389 5803

COIL CHARACTERISTICS (Vdc)

CODE	A	B	C	M	N [7]	R [7]	V [7]
Nominal operating voltage	28	12	6	48	28	12	6
Maximum operating voltage	29	14.5	7.3	50	29	14.5	7.3
Maximum pickup voltage							
- Cold coil at +125° C	18	9	4.5	36	18	9	4.5
- During high temp test at +125° C	19.8	9.9	5	38	19.8	9.9	5
- During continuous current test at +125° C	22.5	11.25	5.7	42	22.5	11.25	5.7
Maximum drop-out voltage	7	4.5	2.5	14	7	4.5	2.5
Coil resistance $\Omega \pm 10\%$ at +25° C except types "C" and "V" +20%, -10%	290	70	18	890	290	70	18

GENERAL CHARACTERISTICS

Temperature range	-70°C to +125°C
Minimum operating cycles (life) at rated load	50,000 [3]
Minimum operating cycles (life) at 25% rated load	200,000
Dielectric strength at sea level	
- All circuits to ground and circuit to circuit	1250 Vrms
- Coil to ground	1000 Vrms
Dielectric strength at altitude 80,000 ft	500 Vrms [4]
Insulation resistance	
- Initial (500 Vdc)	100 M Ω min
- After environmental tests (500 Vdc)	50 M Ω min
Sinusoidal vibration (A and D mounting)	0.12 d.a. / 10 to 70 Hz 30G / 70 to 3000 Hz
Sinusoidal vibration (J mounting)	0.12 d.a. / 10 to 57 Hz 20G / 57 to 3000 Hz
Random vibration	
- Applicable specification	MIL-STD-202
- Method	214
- Test condition - A and D mounting	1G (0.4G ² /Hz, 50 to 2000 Hz)
- Test condition – G and J mounting	1E (0.2G ² /Hz, 50 to 2000 Hz)
- Duration	15 minutes each plane
Shock (A, D and W mounting)	200G / 6 \pm 1 ms
Shock (J mounting)	100G / 6 \pm 1 ms
Maximum contact opening time under vibration and shock	10 μ s
Operate time at nominal voltage @25°C	15 ms max
Release time at nominal voltage @25°C	15 ms max
Contact make bounce at nominal voltage @25°C	1 ms max
Contact release break bounce at nominal voltage @25°C	0.1 ms max [8]
Weight maximum	0.188 lb

Unless otherwise noted, the specified temperature range applies to all relay characteristics.

Dimensions in inches
Tolerances, unless otherwise specified, ± 0.03 in

MOUNTING STYLES

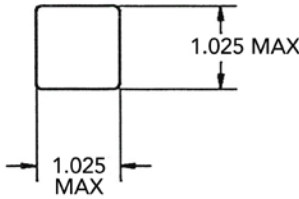
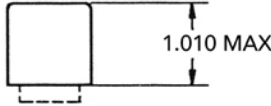

MOUNTING STYLE A

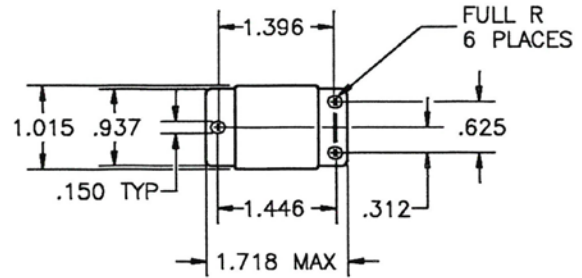
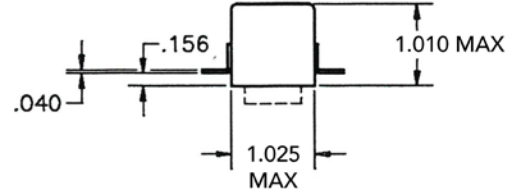

MOUNTING STYLE D

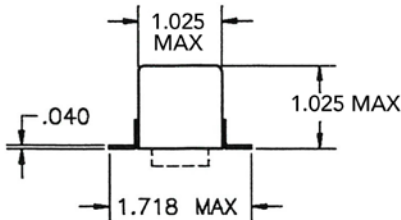
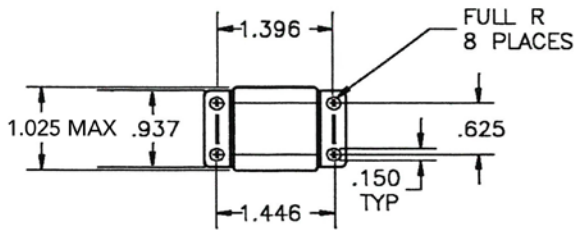

MOUNTING STYLE J

NOTE:
FOR USE WITH
TRACK MOUNT SYSTEM

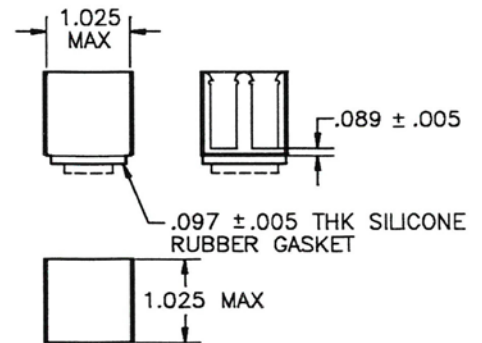

MOUNTING STYLE W

TERMINAL TYPES

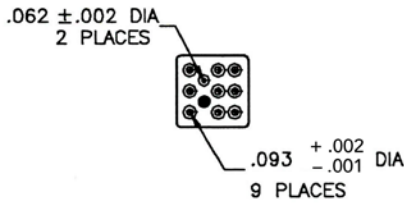
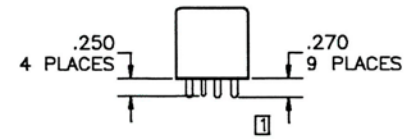

CONTACT ROBISON ELECTRONICS, SAN LUIS OBISPO
CA FOR INSULATOR PART NUMBER.

TERMINAL TYPE 1

FINISH:
CASE: TIN/LEAD (all M83536 qualified relays)
BLUE PAINT (upon request)

TERMINALS: TIN/LEAD PLATE

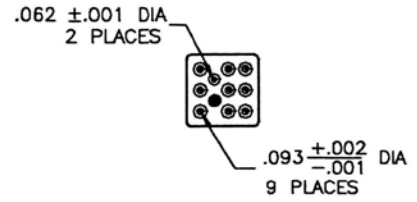
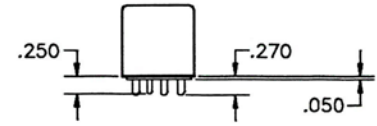

TERMINAL TYPE 4

FINISH:
CASE: TIN/LEAD (all M83536 qualified relays)
BLUE PAINT (upon request)

TERMINALS: GOLD PLATED

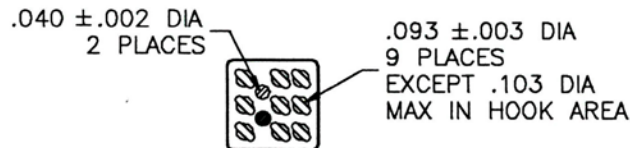
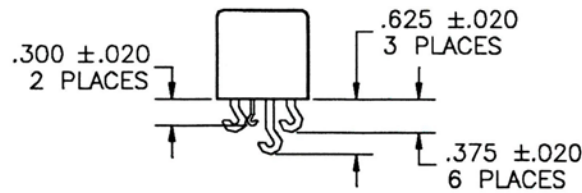

TERMINAL TYPE 2

FINISH:
CASE: TIN/LEAD (all M83536 qualified relays)
BLUE PAINT (upon request)

TERMINALS: TIN/LEAD PLATE

DIAGRAMS

SCHEMATIC DIAGRAM

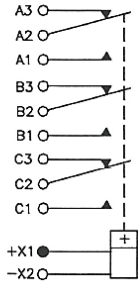

STANDARD TERMINAL LAYOUT

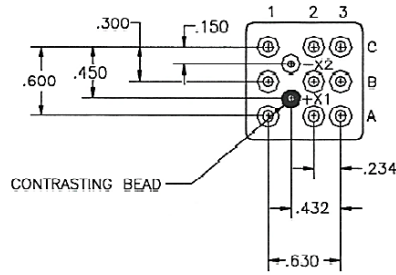

WIRING DIAGRAMS

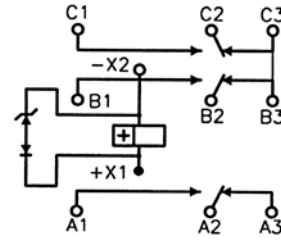

With EMF Suppression [7]

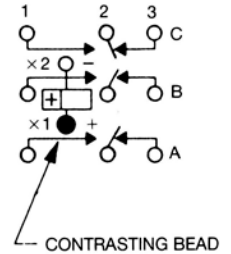

TOL: .XX ±.03; .XXX ±.010

NUMBERING SYSTEM

KC - D 1 A - XXX

Basic series designation

1. Mounting styles (A, D, J, W)
2. Terminal types (1, 2, 4,)
3. Coil voltage, see coil characteristics (A, B, C, M, N, R, V)
4. XXX Designators

Example : KC-A1A-XXX

- KC-D1A (Commercial)
- KC-D1A-300 L,M (MIL)
- KC-D1A-123 (Customer Part)

NOTES

1. Standard Intermediate current test applicable
2. For full rated load, max. temp. and altitude use no. 12 wire or larger.
Solder hook relays to be mounted to limit mounting bracket temp. to 160° C.
3. DC inductive load 10,000 cycles, AC inductive load 20,000 cycles.
4. 500 Vrms with silicone gasket compressed, 350 Vrms all other conditions.
5. Applicable military specification: MIL-PRF-83536.
6. Special models available: Dry circuit, high reliability testing, etc.
7. "N, R & V" coils have back EMF suppression to - 42 volts maximum.
8. Applies to "N, R & V" coils only
9. 60 Hz load life, 10,000 cycles.
10. Time current relay characteristics per MIL-PRF-83536
11. Relay will not operate, but will not be damaged by application of reverse polarity to coil.

For any inquiries, please contact your local Esterline Power Systems representative
<http://www.esterline.com/powersystems/Contact/TheAmericas.aspx>