

BIPOLAR ANALOG INTEGRATED CIRCUITS

μ PC8194K, μ PC8195K

RX/TX-IF SiMMIC FOR W-CDMA

DESCRIPTION

The μ PC8194K and μ PC8195K are silicon monolithic integrated circuit designed as receiver (RX) and transmitter (TX) IF section for W-CDMA. The μ PC8194K is an RX-IF IC including IF-AGC amplifier and demodulator. The μ PC8195K is a TX-IF IC including IF-AGC amplifier and quadrature modulator. These two ICs are suitable for kit-use for W-CDMA IF section.

The ICs are developed using our new ultra high speed silicon bipolar process.

FEATURES

- RX-IF: 190 MHz, TX-IF: 380 MHz
- Low power consumption
- Built-in power saving function
- Small size: 20-pin plastic QFN package (3.2 × 4.2 × 0.8 mm)

APPLICAION

- W-CDMA

ORDERING INFORMATION

Part Number	Package	Supplying Form
μ PC8194K-E1	20-pin plastic QFN (3.2 × 4.2 × 0.8 mm)	• Embossed tape 12 mm wide
μ PC8195K-E1		• Pin 1 indicates pull-out direction of tape • Qty 2.5 kpcs/reel

Remark To order evaluation samples, contact your nearby sales office.

Part number for sample order: μ PC8194K, μ PC8195K

Caution electro-static sensitive devices.

The information in this document is subject to change without notice. Before using this document, please confirm that this is the latest version.
Not all devices/types available in every country. Please check with local NEC Compound Semiconductor Devices representative for availability and additional information.

APPLICATION EXAMPLE

Variation of IF plan μ PC8190K, μ PC8191K: RX-IF = 380 MHz, TX-IF = 570 MHz
 μ PC8194K, μ PC8195K: RX-IF = 190 MHz, TX-IF = 380 MHz

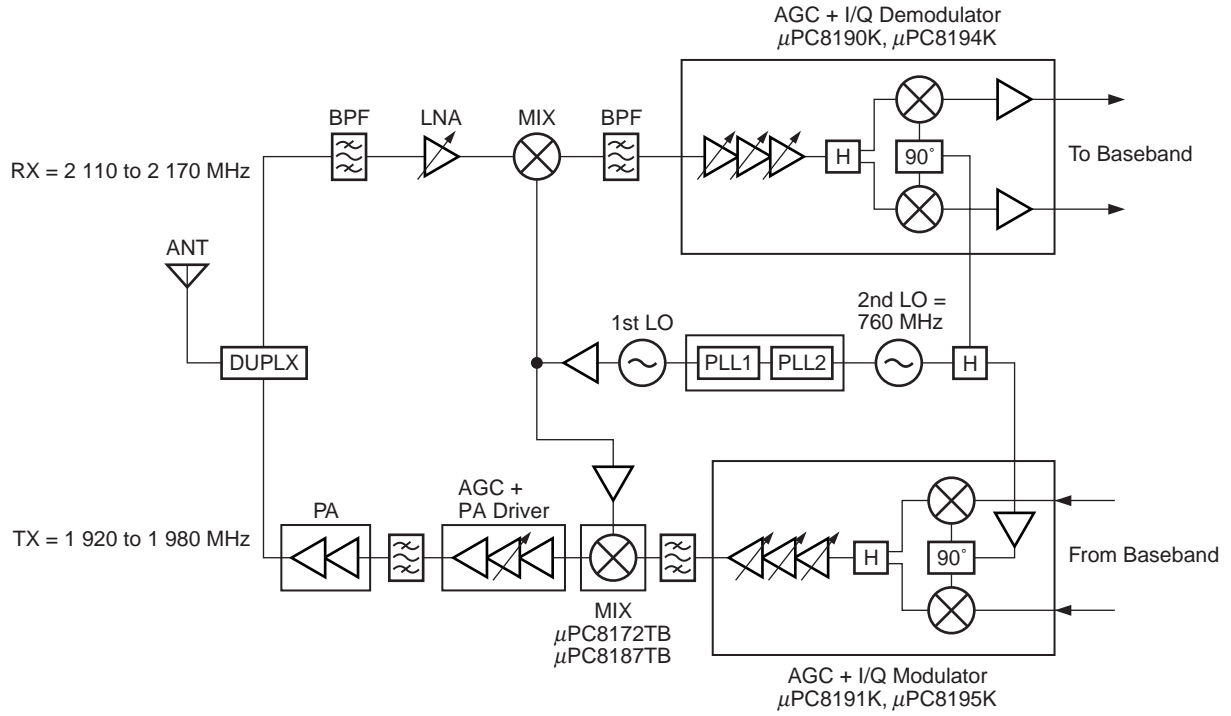

INTERNAL BLOCK DIAGRAM AND PIN CONFIGURATION – μ PC8194K (RX) –

(Top View)

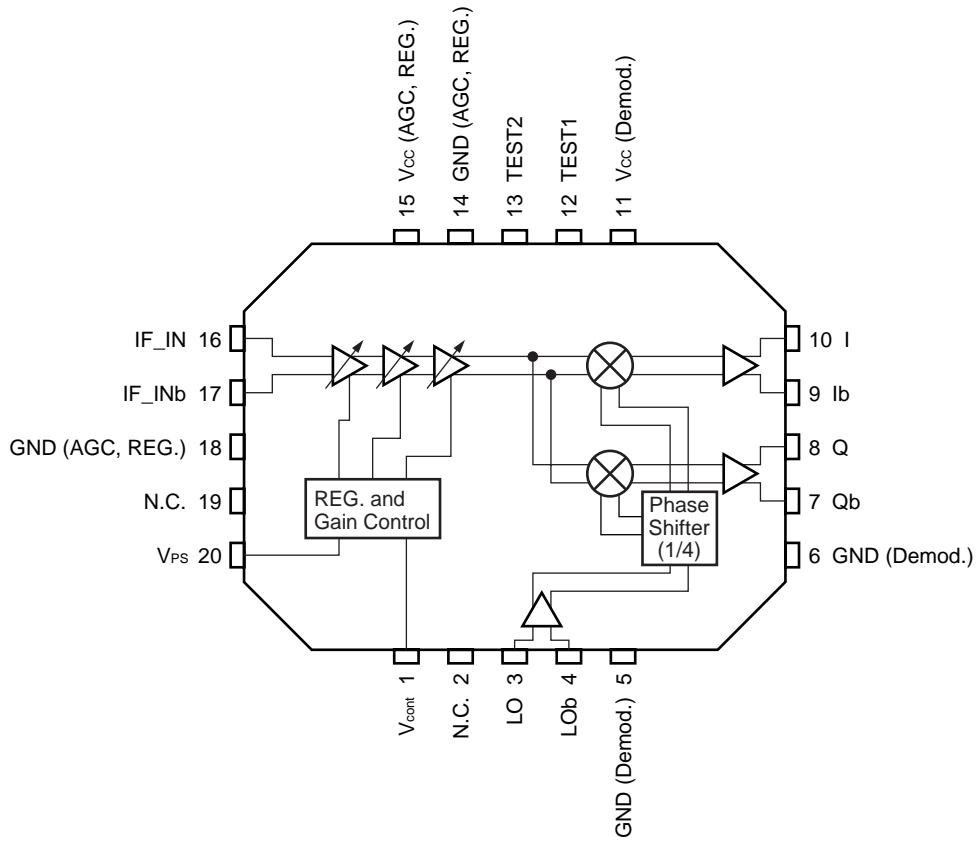

DIFFERENCE OF INTERNAL BLOCK DIAGRAM

- μ PC8190K: Divide-by-2 F/F phase shifter
- μ PC8194K: Divide-by-4 F/F phase shifter

PIN EXPLANATIONS – μPC8194K (RX) –

Pin No.	Pin Name	Applied Voltage (V)	Pin Voltage (TYP.) (V) <small>Note</small>	Functions and Applications	Internal Equivalent Circuits
1	V _{cont}	0 to V _{cc}	–	Gain control pin of AGC amplifier. Variable gains are available in accordance with applied voltage.	
2 19	N.C.	–	–	Non connection. This pin is not connected to internal circuit. This pin should be opened or grounded.	—
3	LO	–	1.96	Local signal input pin of I/Q demodulator. Input frequency is 760 MHz.	
4	LOb	–	1.96	Bypass pin of local signal input for I/Q demodulator. In the case of single local input, this pin must be decoupled with capacitor ex. 100 to 1 000 pF.	
5 6	GND (Demod.)	0	–	Ground pin of I/Q demodulator. This pin should be grounded with minimum inductance. Form the ground pattern as widely as possible to minimize ground impedance.	—
7	Qb	–	1.40	I/Q/Ib/Qb signal output pins. Each pin is an emitter follower.	
8	Q	–	1.40	Each of Ib and Qb is differential output of I and Q.	
9	Ib	–	1.40	Recommendable load impedance is 10 to 20 kΩ.	
10	I	–	1.40		

Note Pin voltage is measured at V_{cc} = 3.0 V

– μPC8194K (RX) –

Pin No.	Pin Name	Applied Voltage (V)	Pin Voltage (TYP.) (V) ^{Note}	Functions and Applications	Internal Equivalent Circuits
11	V _{CC} (Demod.)	2.7 to 3.3	–	Supply voltage pin of I/Q demodulator (phase shifter + I/Q Mixer).	—
12	TEST 1	0	–	TEST pin. In actual use, this pin should be grounded.	—
13	TEST 2	0	–		
14 18	GND (AGC, REG.)	0	–	Ground pin of AGC amplifier and internal regulator. This pin should be grounded with minimum inductance. Form the ground pattern as widely as possible to minimize ground impedance.	—
15	V _{CC} (AGC, REG.)	2.7 to 3.3	–	Supply voltage pin of AGC amplifier and internal regulator.	—
16	IF_IN	–	2.75	IF signal input pin. This pin is input of AGC amplifier. Balance input between 16, 17 pin. Input frequency is 190 MHz.	
17	IF_INb	–	2.75	IF signal input pin. In the case of single input, this pin must be decoupled with capacitor.	
20	V _{PS}	H: 2.2 to V _{CC} L: 0 to 0.5	–	Power saving pin. This pin modulator can control Active/Sleep state with bias as follows.	

V _{PS} (V)	State
0 to 0.5	Sleep Mode
2.2 to 3	Active Mode

Note Pin voltage is measured at V_{CC} = 3.0 V

ABSOLUTE MAXIMUM RATINGS – μ PC8194K (RX) –

Parameter	Symbol	Ratings	Unit
Supply Voltage	V _{CC}	4.0	V
Applied Voltage	V _{PS} , V _{cont}	-0.3 to V _{CC} + 0.3	V
Operating Ambient Temperature	T _A	-40 to +85	°C
Storage Temperature	T _{stg}	-55 to +150	°C
Power Dissipation	P _D	309	mW

RECOMMENDED OPERATING RANGE – μ PC8194K (RX) –

Parameter	Symbol	MIN.	TYP.	MAX.	Unit
Supply Voltage	V _{CC}	2.7	3.0	3.3	V
Operating Ambient Temperature	T _A	-25	25	85	°C
IF Frequency	f _{IF}	-	190	-	MHz
Local Frequency	f _{LO}	-	760	-	MHz
Local Input Level	P _{LO}	-18	-15	-12	dBm
I/Q Output Frequency	f _{I/Q}	-	-	10	MHz

ELECTRICAL CHARACTERISTICS – μ PC8194K (RX) – (Unless otherwise specified, V_{CC} = 3.0 V, T_A = +25°C, f_{IF} = 192.5 MHz, f_{LO} = 760 MHz, P_{LO} = -15 dBm, f_{I/Q} = 2.5 MHz)

Parameter	Symbol	Test Conditions	MIN.	TYP.	MAX.	Unit
Circuit Current	I _{CC}	No input signal	-	9.3	12.6	mA
		At power-saving mode	-	-	1	μA
Voltage Gain	V _{G1}	V _{cont} = 2.5 V	70	77	-	dB
	V _{G2}	V _{cont} = 0.5 V	-	-	-20	dB
Input 3rd Order Intercept Point	IIP ₃₁	Gain = +65 dB (R _S = 600 Ω balanced), P _{IFin} = -76 dBm	-60	-55	-	dBm
	IIP ₃₂	Gain = -10 dB (R _S = 600 Ω balanced), P _{IFin} = -10 dBm	0	3	-	dBm
Local Leakage	LOL	Leakage to I/Q port when local = 190 MHz and output = 30 mV _{P-P} balanced	-	-	-20	dBc
I/Q Bandwidth	f _{I/Q(BW)}	3 dB down	10	-	-	MHz
I/Q Maximum Output Swing	V _{O (sat)}	Balanced output	1	-	-	V _{P-P}
I/Q Gain Balance	AE	f _{I/Q} = 2.5 MHz	-	-	Δ0.5	dB
I/Q Phase Error	PE	f _{I/Q} = 2.5 MHz	-	-	±3	deg.
Gain Accuracy	G _{acc}	V _{cont} = 1 to 2 V	-	Δ4.6	Δ6	dB/V
Rise Time from Power-saving Mode	t _{PS}		-	-	20	μs
Rising Voltage from Power-saving Mode	V _{PS on}		2.2	-	-	V
Falling Voltage from Power-saving Mode	V _{PS off}		-	-	0.5	V
Gain Flatness	Flat	f _{IF} ± 2.5 MHz	-	-	Δ0.5	dB

STANDARD CHARACTERISTICS FOR REFERENCE – μ PC8194K (RX) – (Unless otherwise specified, $V_{CC} = 3.0\text{ V}$, $T_A = +25^\circ\text{C}$, $f_{IF} = 192.5\text{ MHz}$, $f_{LO} = 760\text{ MHz}$, $P_{LO} = -15\text{ dBm}$, $f_{IQ} = 2.5\text{ MHz}$)

Parameter	Symbol	Test Conditions	MIN.	TYP.	MAX.	Unit
Noise Figure	NF	Gain = +65 dB	–	9.5	–	dB
Error Vector Magnitude (Vector Error)	EVM	IF = 190 MHz, 3.84 Msps QPSK modulation, gain is adujsted	–	3	–	%rms
Gain 1 dB Compression Input Power	$P_{in(1\text{ dB})}$	Gain = +50 dB	–	-50	–	dBm

MEASUREMENT CIRCUIT – μ PC8194K (RX) –

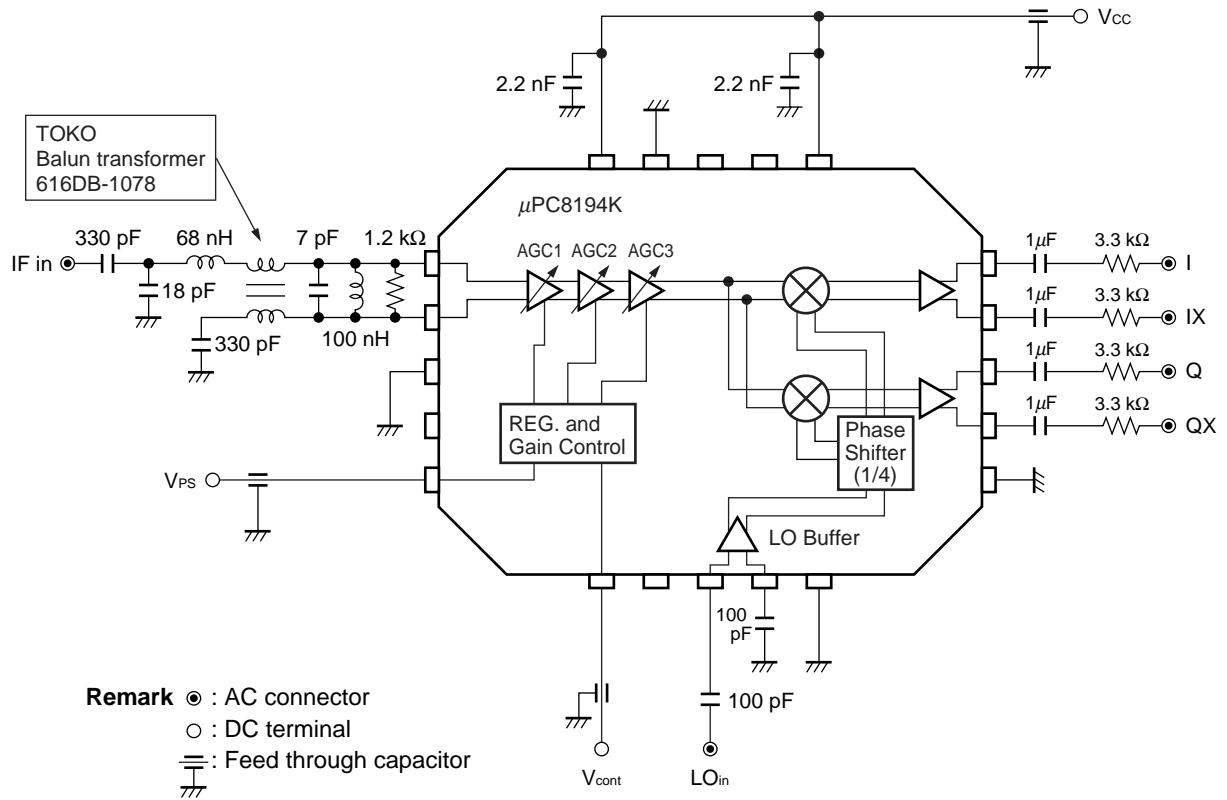

TYPICAL CHARACTERISTICS – μ PC8194K (RX) – ($V_{CC} = 3.0$ V, $V_{PS} = 2.5$ V, $f_{IF} = 192.5$ MHz, $f_{LO} = 760$ MHz, $P_{LO} = -15$ dBm, $f_{I/Q} = 2.5$ MHz, $V_{I/Q} = 400$ mV_{P-P} balance)

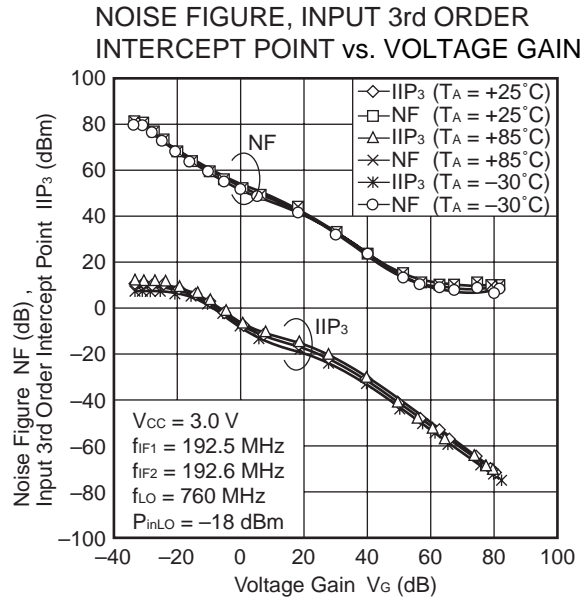
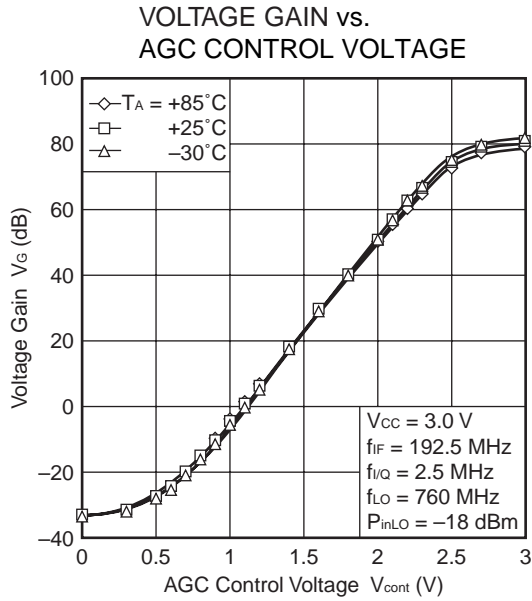

PIN EXPLANATIONS – μ PC8195K (TX) –

Pin No.	Pin Name	Applied Voltage (V)	Pin Voltage (TYP.) (V) <small>Note</small>	Functions and Applications	Internal Equivalent Circuits						
1	Qb	$V_{CC}/2$	–	Q signal input pin. Apply bias voltage externally. Maximum balance input voltage is 1 000 mV _{P-P} (balance).							
2	Q	$V_{CC}/2$	–								
3	GND (Shifter)	0	–	Ground pin of I/Q modulator. This pin should be grounded with minimum inductance. Form the ground pattern as widely as possible to minimize ground impedance.	—						
4	N.C.	0	–	Non connection.	—						
5				This pin is not connected to internal circuit. This pin should be opened or grounded.	—						
6	LOb	0	2.02	Bypass pin of local signal input for I/Q modulator. In the case of single local input, this pin must be decoupled with capacitor ex. 1 000 pF.	—						
7	LO	0	2.02	Local signal input of I/Q modulator. The DC cut capacitor ex. 1 000 pF must be attached to this pin.	—						
8	V_{CC} (Shifter)	2.7 to 3.3	–	Supply voltage pin of I/Q modulator.	—						
9	V_{PS}	0 to 3.0	–	Power saving pin of I/Q modulator + AGC amplifier. This pin modulator can control Active/Sleep state with bias as follows. <table border="1" style="margin: 10px auto;"> <thead> <tr> <th>V_{PS} (V)</th> <th>State</th> </tr> </thead> <tbody> <tr> <td>0 to 0.5</td> <td>Sleep Mode</td> </tr> <tr> <td>2.2 to 3</td> <td>Active Mode</td> </tr> </tbody> </table>	V_{PS} (V)	State	0 to 0.5	Sleep Mode	2.2 to 3	Active Mode	
V_{PS} (V)	State										
0 to 0.5	Sleep Mode										
2.2 to 3	Active Mode										

Note Pin voltage is measured at $V_{CC} = 3.0$ V

– μPC8195K (TX) –

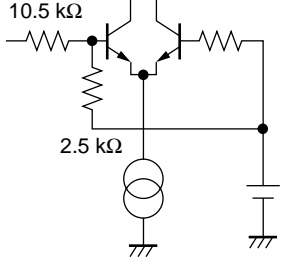
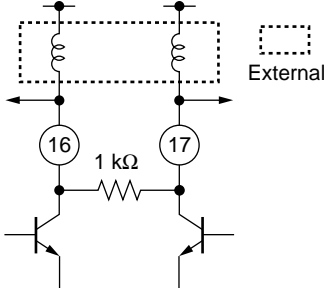
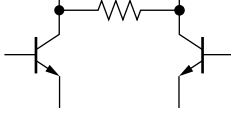
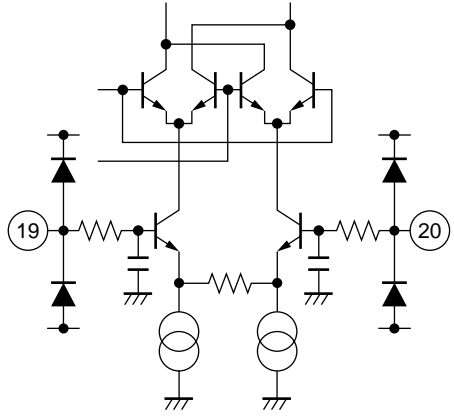
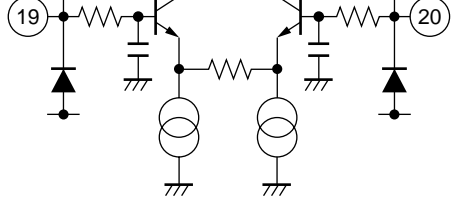
Pin No.	Pin Name	Applied Voltage (V)	Pin Voltage (TYP.) (V) ^{Note}	Functions and Applications	Internal Equivalent Circuits
10	V _{cont}	0 to 3.0	–	Gain control pin of AGC amplifier. Variable gains are available in accordance with applied voltage between 0 to 3.0 V.	
11	V _{CC} (REG.)	2.7 to 3.3	–	Supply voltage pin of internal regulator.	—
12	GND (REG.)	0	–	Ground pin internal regulator. This pin should be grounded with minimum inductance. Form the ground pattern as widely as possible to minimize ground impedance.	—
13 14 18	GND (AGC, MIX)	0	–	Ground pin of AGC amplifier + I/Q Mixer. This pin should be grounded with minimum inductance. Form the ground pattern as widely as possible to minimize ground impedance.	—
15	V _{CC} (AGC, MIX)	2.7 to 3.3	–	Supply voltage pin of AGC amplifier + I/Q Mixer.	—
16	IFout	2.7 to 3.3	–	IF output pin. The inductor must be attached between V _{CC} and output pin due to open collector. Output frequency is 380 MHz which is 1/2 of local signal frequency 760 MHz.	
17	IFoutb	2.7 to 3.3	–	Balance output of IFout pin. The inductor must be attached between V _{CC} and output pin due to open collector.	
19	I	V _{CC} /2	–	I signal input pin. Apply bias voltage externally. Maximum balance input voltage is 1 000 mV _{P-P} (balance).	
20	I _b	V _{CC} /2	–		

Note Pin voltage is measured at V_{CC} = 3.0 V

ABSOLUTE MAXIMUM RATINGS – μ PC8195K (TX) –

Parameter	Symbol	Ratings	Unit
Supply Voltage	V _{CC}	4.0	V
Applied Voltage	V _{PS} , V _{cont}	-0.3 to V _{CC} + 0.3	V
Operating Ambient Temperature	T _A	-40 to +85	°C
Storage Temperature	T _{stg}	-55 to +150	°C
Power Dissipation	P _D	309	mW

RECOMMENDED OPERATING RANGE – μ PC8195K (TX) –

Parameter	Symbol	Test Conditions	MIN.	TYP.	MAX.	Unit
Supply Voltage	V _{CC}		2.7	3.0	3.3	V
Operating Ambient Temperature	T _A		-25	25	85	°C
IF Frequency	f _{IF}		-	380	-	MHz
Local Frequency	f _{LO}		-	760	-	MHz
Local Input Level	P _{LO}		-18	-15	-12	dBm
IF Output Impedance	Z _{IF}	Balance output internal resistance	-	1	-	k Ω
I/Q Maximum Input Voltage	V _{I/Q}	Balance input	-	0.4	1	V _{P-P}

ELECTRICAL CHARACTERISTICS – μ PC8195K (TX) –

(Unless otherwise specified, V_{CC} = 3.0 V, T_A = +25°C, f_{IF} = 380.01 MHz, f_{LO} = 760 MHz, P_{LO} = -15 dBm, f_{I/Q} = 10 kHz, 400 mV_{P-P} balanced sine-wave)

Parameter	Symbol	Test Conditions	MIN.	TYP.	MAX.	Unit
Circuit Current	I _{CC}	No input signal	-	25.5	30.0	mA
		At power-saving mode	-	-	1	μ A
Output Power	P _{out1}	V _{cont} = 2.3 V, I/Q = 400 mV _{P-P} balanced	-17	-13	-	dBm
	P _{out2}	V _{cont} = 0.3 V, I/Q = 400 mV _{P-P} balanced	-	-88	-83	dBm
Local Leakage	LOL		-	-	-30	dBc
Image Rejection	ImR		-	-	-30	dBc
Rise Time from Power-saving Mode	t _{ps}		-	-	10	μ s
Rising Voltage from Power-saving Mode	V _{PS on}		2.2	-	-	V
Falling Voltage from Power-saving Mode	V _{PS off}		-	-	0.5	V

STANDARD CHARACTERISTICS FOR REFERENCE – μ PC8195K (TX) –

(Unless otherwise specified, $V_{CC} = 3.0\text{ V}$, $T_A = +25^\circ\text{C}$, $f_{IF} = 380.01\text{ MHz}$, $f_{LO} = 760\text{ MHz}$, $P_{LO} = -15\text{ dBm}$, $f_{IQ} = 10\text{ kHz}$, 400 mV_{P-P} balanced sine-wave)

Parameter	Symbol	Test Conditions	MIN.	TYP.	MAX.	Unit
Output Noise Level 1	NFL1	$P_{out} = -25\text{ dBm}$, $f_{IF} \pm 20\text{ MHz}$	–	-147	–	dBm/Hz
Output Noise Level 2	NFL2	$P_{out} = -65\text{ dBm}$, $f_{IF} \pm 20\text{ MHz}$	–	-160	–	dBm/Hz
Error Vector Magnitude (Vector Error)	EVM		–	3	–	%rms
Adjacent Channel Power	ACPR	$f_{IF} \pm 5\text{ MHz}$	–	-55	–	dBc

TYPICAL CHARACTERISTICS – μ PC8195K (TX) – ($V_{CC} = 3.0$ V, $V_{PS} = 2.5$ V, $f_{IF} = 380.01$ MHz, $f_{LO} = 760$ MHz, $P_{LO} = -15$ dBm, $f_{IQ} = 10$ MHz, $V_{IQ} = 400$ mV_{P-P} balance)

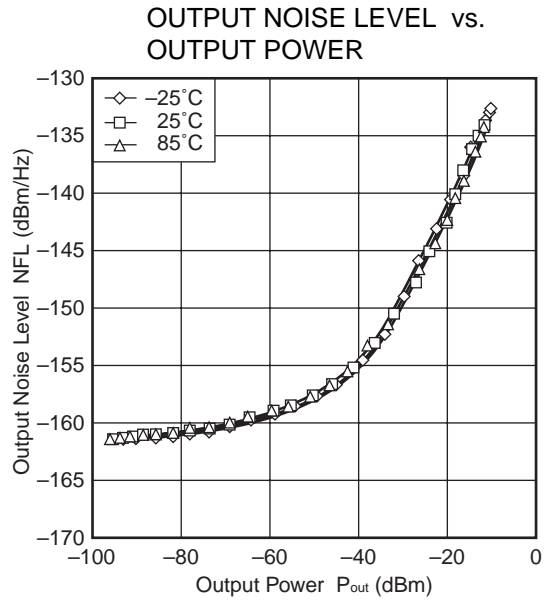
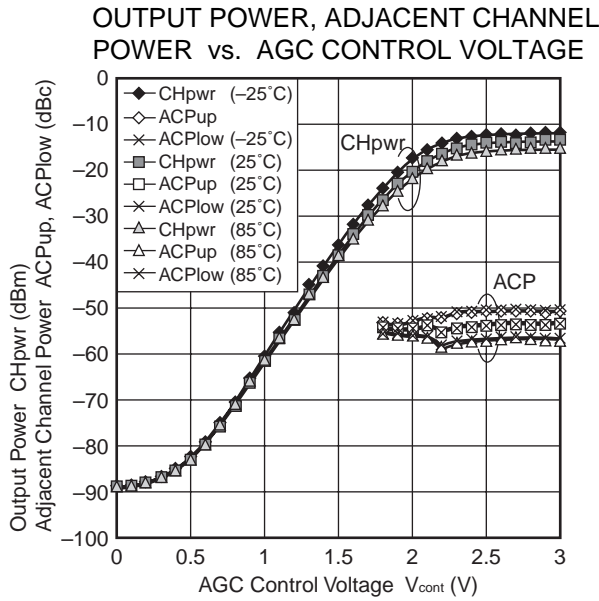

PACKAGE DIMENSIONS

20-PIN PLASTIC QFN (PIN-PITCH: 0.4 mm, UNIT: mm)

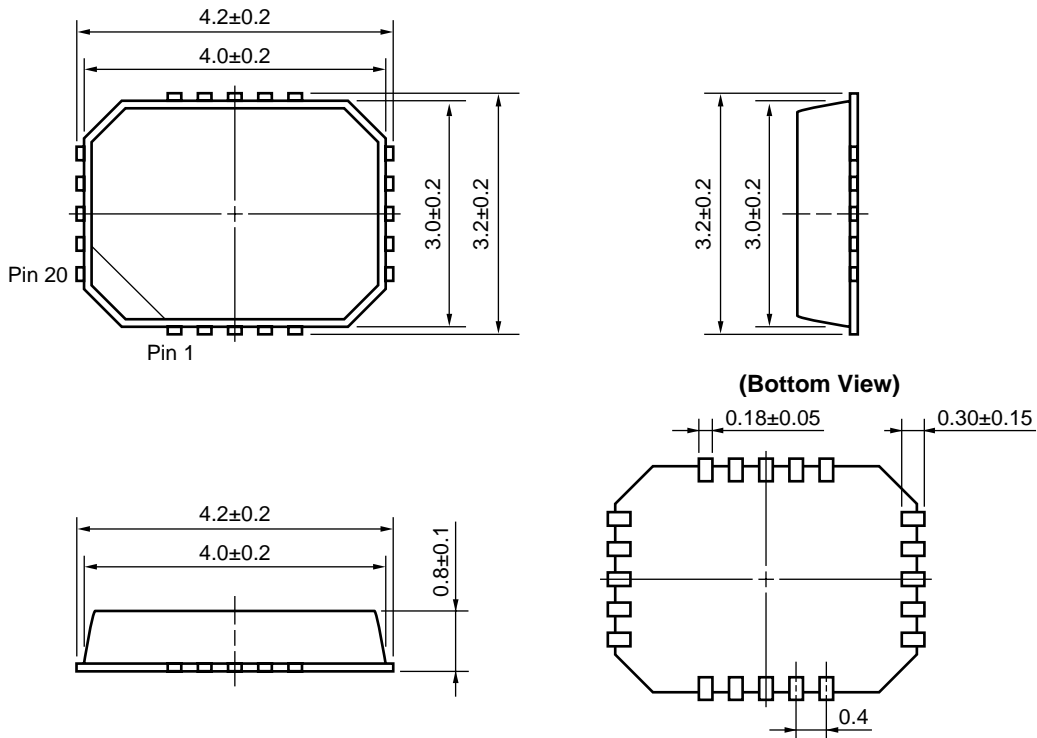

NOTE ON CORRECT USE

- (1) Observe precautions for handling because this IC is an electrostatic sensitive device.
- (2) Form a ground pattern as widely as possible to minimize its impedance (to prevent undesires oscillation).
- (3) Keep the track length of the ground pins as short as possible.
- (4) Connect a bypass capacitor to the Vcc pin.

RECOMMENDED SOLDERING CONDITIONS

This product should be soldered and mounted under the following recommended conditions. For soldering methods and conditions other than those recommended below, contact your nearby sales office.

Soldering Method	Soldering Conditions	Condition Symbol
Infrared Reflow	Peak temperature (package surface temperature) : 260°C or below Time at peak temperature : 10 seconds or less Time at temperature of 220°C or higher : 60 seconds or less Preheating time at 120 to 180°C : 120±30 seconds Maximum number of reflow processes : 3 times Maximum chlorine content of rosin flux (% mass) : 0.2%(Wt.) or below	IR260
VPS	Peak temperature (package surface temperature) : 215°C or below Time at temperature of 200°C or higher : 25 to 40 seconds Preheating time at 120 to 150°C : 30 to 60 seconds Maximum number of reflow processes : 3 times Maximum chlorine content of rosin flux (% mass) : 0.2%(Wt.) or below	VP215
Wave Soldering	Peak temperature (molten solder temperature) : 260°C or below Time at peak temperature : 10 seconds or less Preheating temperature (package surface temperature) : 120°C or below Maximum number of flow processes : 1 time Maximum chlorine content of rosin flux (% mass) : 0.2%(Wt.) or below	WS260
Partial Heating	Peak temperature (pin temperature) : 350°C or below Soldering time (per side of device) : 3 seconds or less Maximum chlorine content of rosin flux (% mass) : 0.2%(Wt.) or below	HS350

Caution Do not use different soldering methods together (except for partial heating).

- **The information in this document is current as of November, 2001. The information is subject to change without notice. For actual design-in, refer to the latest publications of NEC's data sheets or data books, etc., for the most up-to-date specifications of NEC semiconductor products. Not all products and/or types are available in every country. Please check with an NEC sales representative for availability and additional information.**
 - No part of this document may be copied or reproduced in any form or by any means without prior written consent of NEC. NEC assumes no responsibility for any errors that may appear in this document.
 - NEC does not assume any liability for infringement of patents, copyrights or other intellectual property rights of third parties by or arising from the use of NEC semiconductor products listed in this document or any other liability arising from the use of such products. No license, express, implied or otherwise, is granted under any patents, copyrights or other intellectual property rights of NEC or others.
 - Descriptions of circuits, software and other related information in this document are provided for illustrative purposes in semiconductor product operation and application examples. The incorporation of these circuits, software and information in the design of customer's equipment shall be done under the full responsibility of customer. NEC assumes no responsibility for any losses incurred by customers or third parties arising from the use of these circuits, software and information.
 - While NEC endeavours to enhance the quality, reliability and safety of NEC semiconductor products, customers agree and acknowledge that the possibility of defects thereof cannot be eliminated entirely. To minimize risks of damage to property or injury (including death) to persons arising from defects in NEC semiconductor products, customers must incorporate sufficient safety measures in their design, such as redundancy, fire-containment, and anti-failure features.
 - NEC semiconductor products are classified into the following three quality grades:
 "Standard", "Special" and "Specific". The "Specific" quality grade applies only to semiconductor products developed based on a customer-designated "quality assurance program" for a specific application. The recommended applications of a semiconductor product depend on its quality grade, as indicated below. Customers must check the quality grade of each semiconductor product before using it in a particular application.
 "Standard": Computers, office equipment, communications equipment, test and measurement equipment, audio and visual equipment, home electronic appliances, machine tools, personal electronic equipment and industrial robots
 "Special": Transportation equipment (automobiles, trains, ships, etc.), traffic control systems, anti-disaster systems, anti-crime systems, safety equipment and medical equipment (not specifically designed for life support)
 "Specific": Aircraft, aerospace equipment, submersible repeaters, nuclear reactor control systems, life support systems and medical equipment for life support, etc.
- The quality grade of NEC semiconductor products is "Standard" unless otherwise expressly specified in NEC's data sheets or data books, etc. If customers wish to use NEC semiconductor products in applications not intended by NEC, they must contact an NEC sales representative in advance to determine NEC's willingness to support a given application.
- (Note)
- (1) "NEC" as used in this statement means NEC Corporation, NEC Compound Semiconductor Devices, Ltd. and also includes its majority-owned subsidiaries.
 - (2) "NEC semiconductor products" means any semiconductor product developed or manufactured by or for NEC (as defined above).

M8E 00.4-0110

► **Business issue**

NEC Compound Semiconductor Devices, Ltd.

5th Sales Group, Sales Division TEL: +81-3-3798-6372 FAX: +81-3-3798-6783 E-mail: salesinfo@csd-nec.com

NEC Compound Semiconductor Devices Hong Kong Limited

Hong Kong Head Office TEL: +852-3107-7303 FAX: +852-3107-7309

Taipei Branch Office TEL: +886-2-8712-0478 FAX: +886-2-2545-3859

Korea Branch Office TEL: +82-2-528-0301 FAX: +82-2-528-0302

NEC Electron Devices European Operations <http://www.nec.de/>

TEL: +49-211-6503-101 FAX: +49-211-6503-487

California Eastern Laboratories, Inc. <http://www.cel.com/>

TEL: +1-408-988-3500 FAX: +1-408-988-0279

► **Technical issue**

NEC Compound Semiconductor Devices, Ltd. <http://www.csd-nec.com/>

Sales Engineering Group, Sales Division

E-mail: techinfo@csd-nec.com FAX: +81-44-435-1918