



SANYO Semiconductors

DATA SHEET

LV8081GQ — Bi-CMOS LSI Two channels Constant-current H-bridge Driver

Overview

The LV8081GQ is a two-channel constant-current driver that supports low-voltage operation. It is optimal for constant-current drive of stepping motors (AF and zoom) in portable equipment such as camera cell phones.

Features

- Two channels constant-current H-bridge driver
- Built-in position detection comparator, SW for the photo reflector (independent control)
- Supports both 2 phase excitation drive and 1-2 phase excitation drive.
- Implemented in a low-power MOS IC process.
- Ultraminiature easy to solder UCT16 package (2.6 × 2.6 × 0.6mm)
- Built-in thermal shutdown circuit and Low voltage shutdown circuit.
- 1.8V input interface with battery supply.
- OUT1-3 short , OUT2-4 short and REG1-2 is short-circuited, and it is possible to correspond as 1ch driver.

Specifications

Absolute Maximum Ratings at Ta = -30 to 85°C (It becomes a design certification excluding 25°C.)

Parameter	Symbol	Conditions	Ratings	Unit
Maximum supply voltage	V _{CC} , V _M max		6.5	V
Output voltage	V _{OUT} max	OUT1, OUT2, OUT3, OUT4	6.5	V
Input voltage	V _{IN} max	CONT, IN	-0.3 to +6.5	V
Ground pin source current	IGND	Per channel	400	mA
Allowable power dissipation	P _d max	Mounted on a circuit board.*	700	mW
Operating temperature	T _{opr}		-30 to +85	°C
Storage temperature	T _{stg}		-40 to +150	°C

* Specified circuit board : 40×50×0.8mm³ : 4-layer (2S2P) glass epoxy printed circuit board

■ Any and all SANYO Semiconductor Co.,Ltd. products described or contained herein are, with regard to "standard application", intended for the use as general electronics equipment (home appliances, AV equipment, communication device, office equipment, industrial equipment etc.). The products mentioned herein shall not be intended for use for any "special application" (medical equipment whose purpose is to sustain life, aerospace instrument, nuclear control device, burning appliances, transportation machine, traffic signal system, safety equipment etc.) that shall require extremely high level of reliability and can directly threaten human lives in case of failure or malfunction of the product or may cause harm to human bodies, nor shall they grant any guarantee thereof. If you should intend to use our products for applications outside the standard applications of our customer who is considering such use and/or outside the scope of our intended standard applications, please consult with us prior to the intended use. If there is no consultation or inquiry before the intended use, our customer shall be solely responsible for the use.

■ Specifications of any and all SANYO Semiconductor Co.,Ltd. products described or contained herein stipulate the performance, characteristics, and functions of the described products in the independent state, and are not guarantees of the performance, characteristics, and functions of the described products as mounted in the customer's products or equipment. To verify symptoms and states that cannot be evaluated in an independent device, the customer should always evaluate and test devices mounted in the customer's products or equipment.

LV8081GQ

Allowable Operating Ratings at $T_a = -30$ to 85°C (It becomes a design certification excluding 25°C .)

Parameter	Symbol	Conditions	Ratings	Unit
Supply voltage	V_{CC}		2.5 to 6.0	V
Range of fixed current setting	I_O	100mA or more is the design certification.	70 to 250	mA
High-level input voltage	V_{IH}	CONT, IN	1.25 to V_{CC}	V
Low-level input voltage	V_{IL}		-0.3 to 0.5	V

Electrical Characteristics at $V_{CC} = 3.0\text{V}$, $T_a = -30$ to 85°C (It becomes a design certification excluding 25°C .)

Parameter	Symbol	Conditions	Ratings			Unit
			min	typ	max	
Current drain	I_{CCO}	IN = 0V		0.1	1	μA
	I_{CCO1}	IN = 3V		0.7	1	mA
	I_{CCO2}	$V_{CC} = 6.5\text{V}$, IN = 6.5V		0.85	1.1	mA
Output on resistance	Ron1	$V_{CC} = 3.0\text{V}$ (High and low side total) EN = 3.0V, $I_{OUT} = 100\text{mA}$		2.0	3.0	Ω
	Ron2	$V_{CC} = 5.0\text{V}$ (High and low side total) EN = 5.0V, $I_{OUT} = 100\text{mA}$		1.50	2.0	Ω
Constant-current output	I_{OUT1}	Between RFG and ground : 1Ω	94	100	106	mA
	I_{OUT2}	Between RFG and ground : 0.5Ω (Design specification)	188	200	212	mA
Output turn-on time	Trise	With RFG1 and RFG2 shorted to ground		1.3	3	μs
Output turn-off time	Tfall	With RFG1 and RFG2 shorted to ground		0.25	0.7	μs
Position detection voltage (high level)	V_H			1.0	1.06	V
Position detection voltage (low level)	V_L		0.74	0.8		V
Detection voltage hysteresis	HYS		0.165	0.18	0.195	V
Comparator input current value	I_{COMPIN}	$V_{COMPIN} = 0\text{V}$		0.15	0.3	μA
Comparator output saturation voltage	V_{Ocomp}	$I_O = 0.5\text{mA}$		0.12	0.21	V
PI/PR pin resistance	RonPIPR	$I_O = 10\text{mA}$		17	32	Ω
PI/PR pin current	$I_{PI/PR}$				20	mA
Input current	I_{IN1}	$V_{IN} = 3\text{V}$		50	85	μA
	I_{IN2}	$V_{IN} = 6.5\text{V}$		120	155	μA

Note : The design specification items are design guarantees and are not measured.

Package Dimensions

unit : mm (typ)

3341

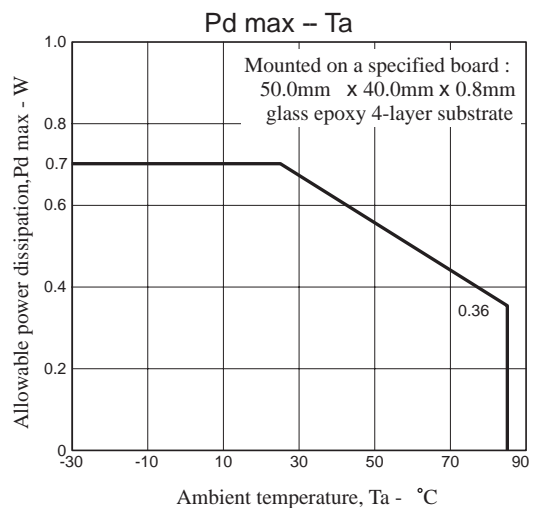
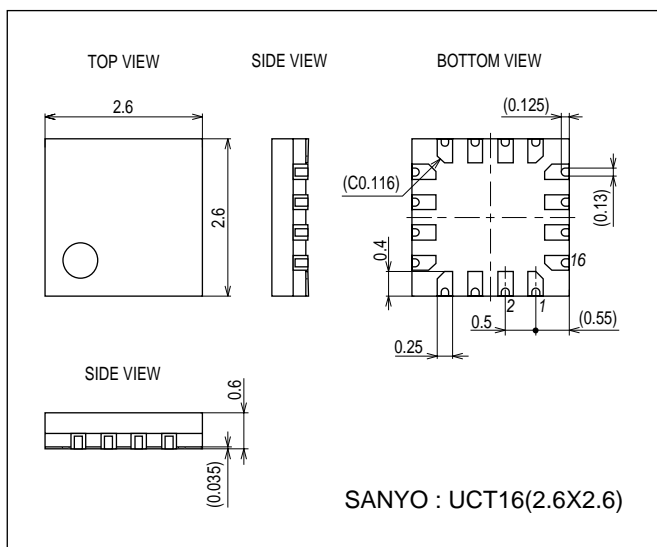

LV8081GQ

Pin Assignment (UCT16)

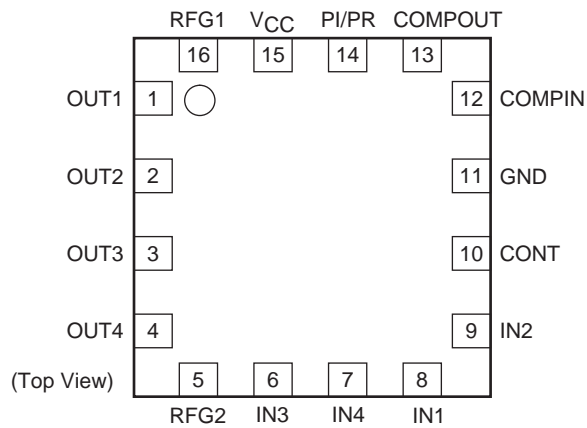

Block Diagram

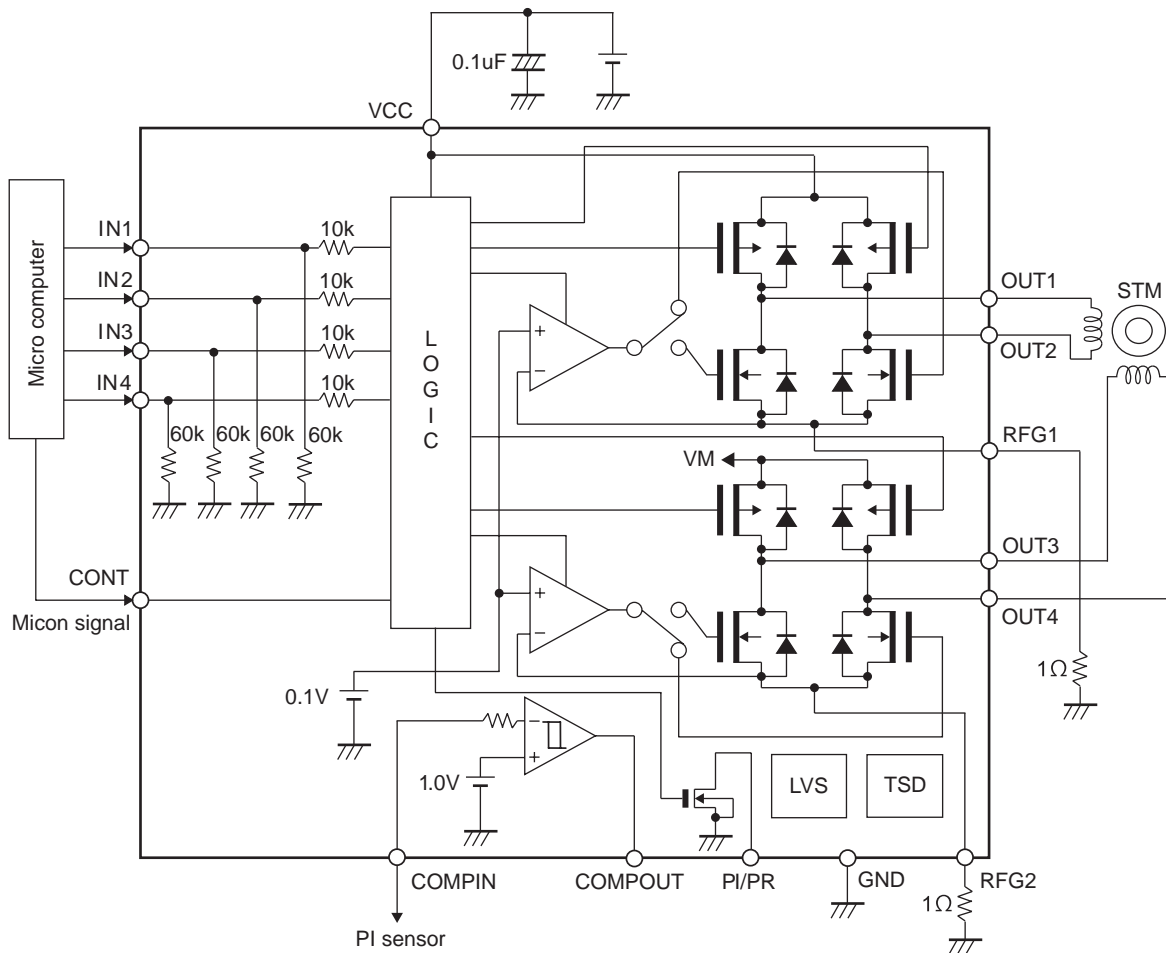

Constant-current calculation : $I_{OUT} = 0.1 \div R_F$ Example : When an I_{OUT} of 100mA is required, R_F must be 1Ω .

Usage Notes

The constant current is set by the resistor R_F connected between RFG and ground according to the formula shown above.

In the electrostatic destruction diode, the terminal PIPR, and the terminal COMP, other terminals are the upper and lower diode specifications only in a lower diode.

LV8081GQ

Truth Table

Input					Output				COMP & PIPR	Mode
IN1	IN2	IN3	IN4	CONT	OUT1	OUT2	OUT3	OUT4		
Low	Low	Low	Low	Low	Off	Off	Off	Off	OFF	Standby mode
Low	High	-	-	High	Low	High	Off	Off	ON	Channel 1, reverse
High	Low				High	Low				Channel 1, forward
High	High				Low	Low				Channel 1, brake mode
-	-	Low	High	High	Off	Off	Low	High	ON	Channel 2, reverse
		High	Low				High	Low		Channel 2, forward
		High	High				Low	Low		Channel 2, brake mode

Note : The "-" input unstable state. When off, a high-impedance state.

- The ENA goes to the standby state with a low-level input, and to the operating state with a high-level input.
- The control input switches the forward/reverse mode.
- The comparator and PIPR can independently control the terminal CONT. It is irrelevant to the state of IN4 from IN1.

Pin Description

Pin No.	Pin Name	Description	Equivalent Circuit
1 2 3 4	OUT1 OUT2 OUT3 OUT4	1-4 : Output pins H-bridge type output pins Pins 1 and 2 are paired and pins 3 and 4 are paired.	
5 16	RFG2 RFG1	5, 16 : Current sensing resistor connection pins Connect the current sensing resistor between these pins and ground to detect the output currents for constant current control. Pin 16 corresponds to the output from pins 1 and 2 and pin 5 to the output from pins 1 and 2.	
11	GND	Ground	

Continued on next page.

LV8081GQ

Continued from preceding page.

Pin No.	Pin Name	Description	Equivalent Circuit
12	COMPIN	Photo reflector position sensing comparator input	
13	COMPOUT	Photo reflector position sensing comparator output This pin serves as an open-collector output of the NPN transistor.	
14	PI/PR	A switch, with NMOS open-drain output, used to turn on/off the power supply of the position sensor unit. When using this switch, connect the position sensor unit between this pin and the V _{CC} pin. On/off control of this switch is accomplished by CONT pin. Setting the CONT pin high turns on the switch.	
15	V _{CC}	Power supply pin	

Timing Chart

(1) Stepper motor timing chart
Timing chart for 2-phase drive

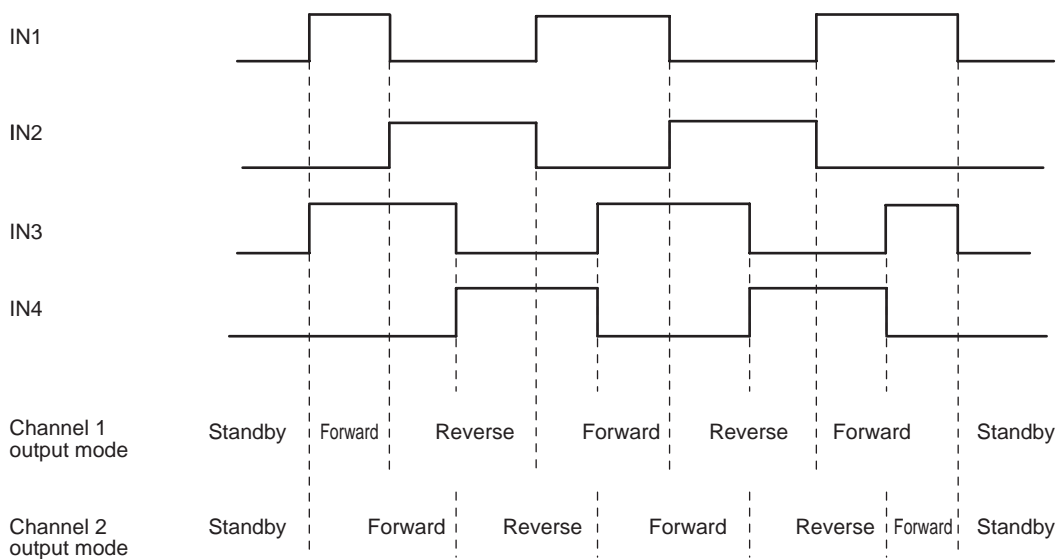

LV8081GQ

(2) Timing chart for 1-2 phase drive (Slow decay mode)

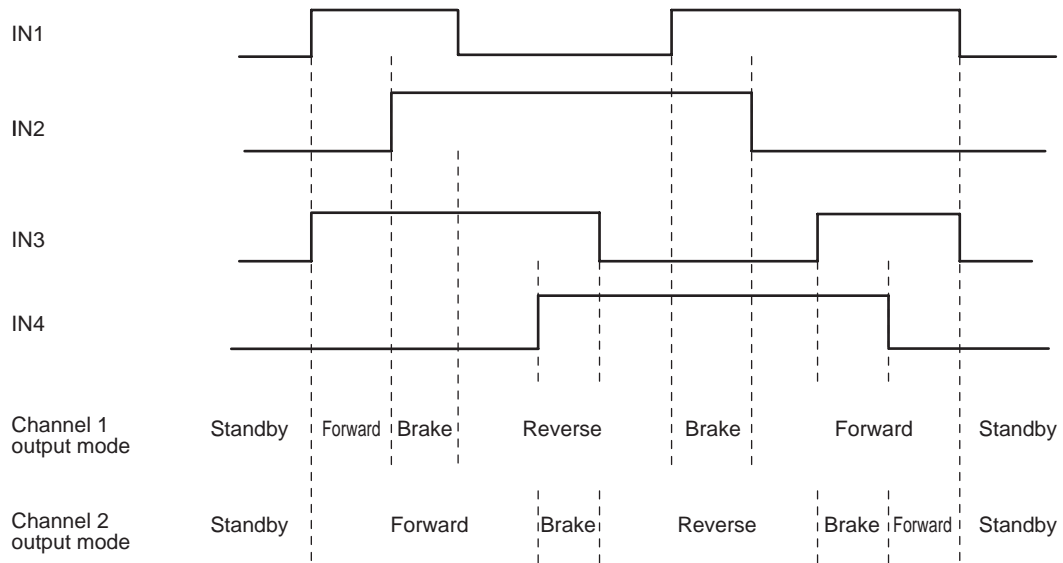

Photosensor Position Detection Application Circuit Example

(a) Application circuit

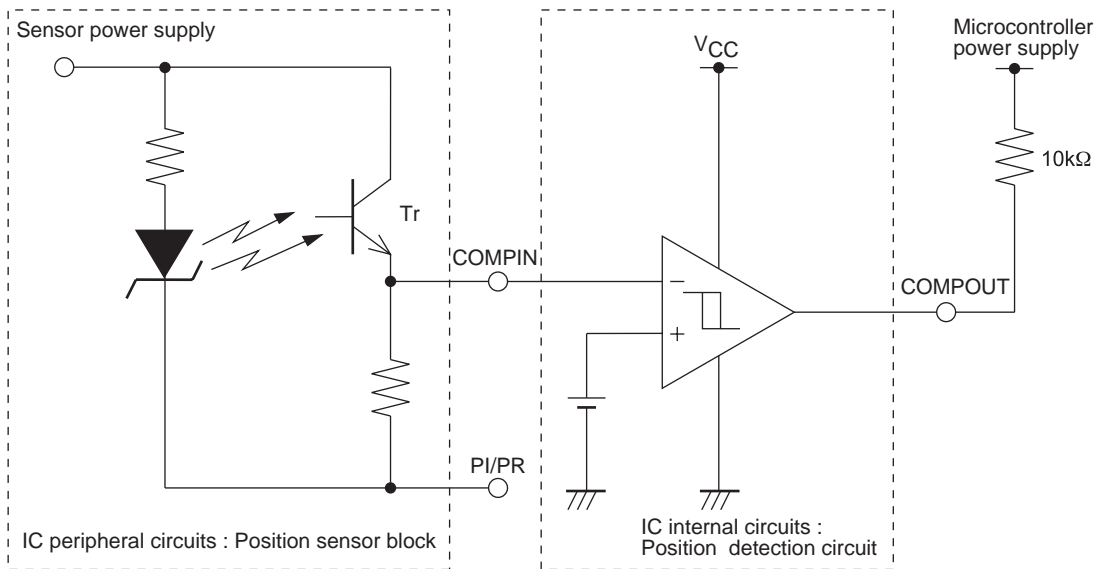

(b) Timing chart

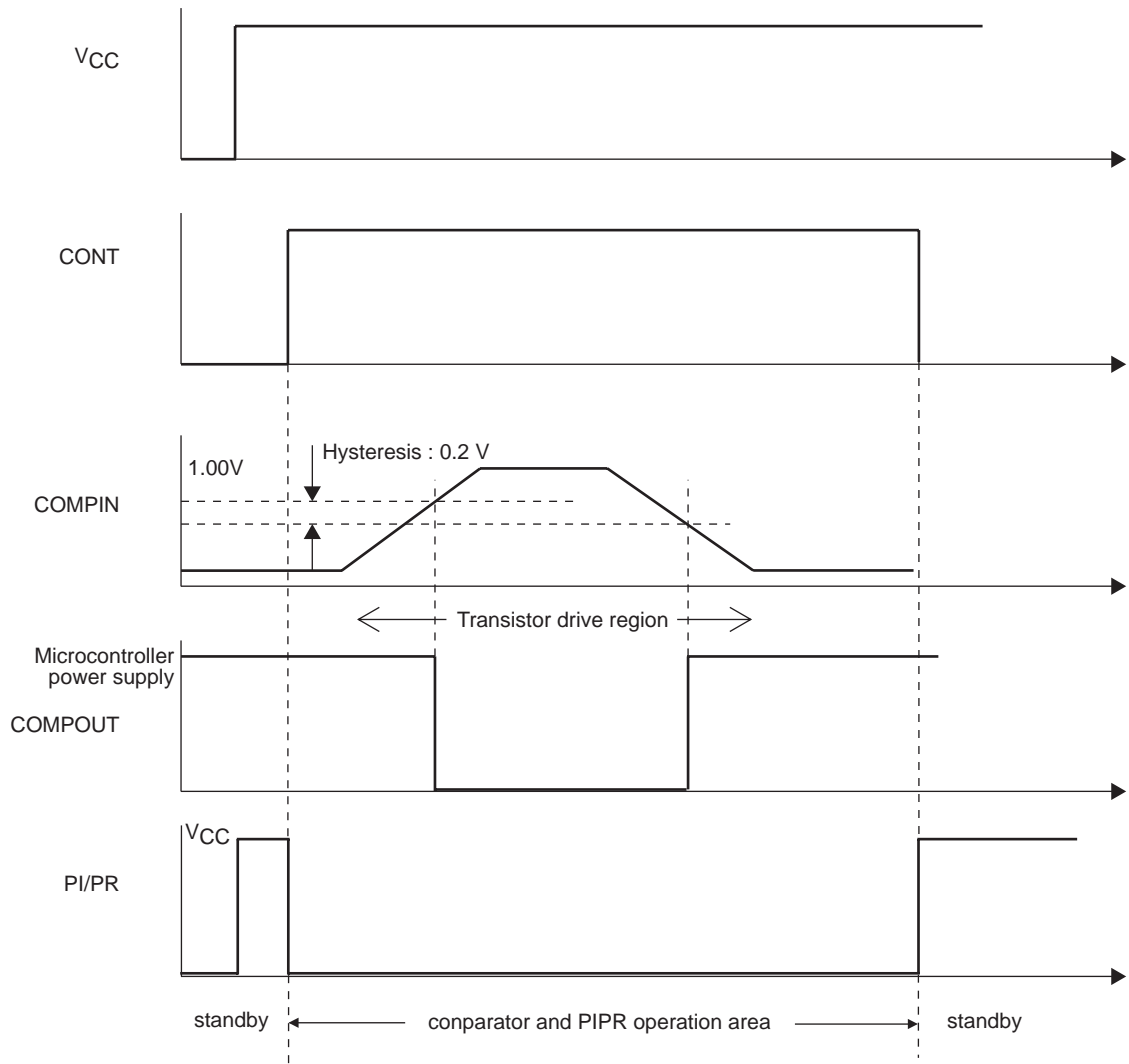

LV8081GQ

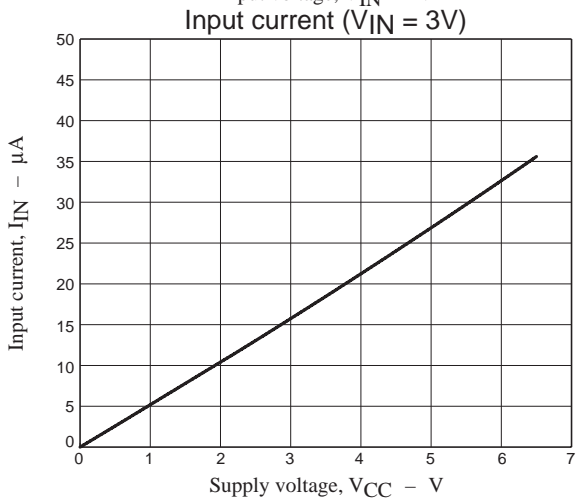
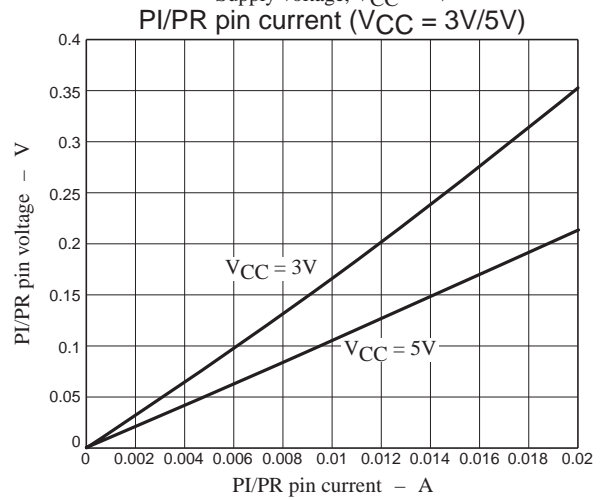
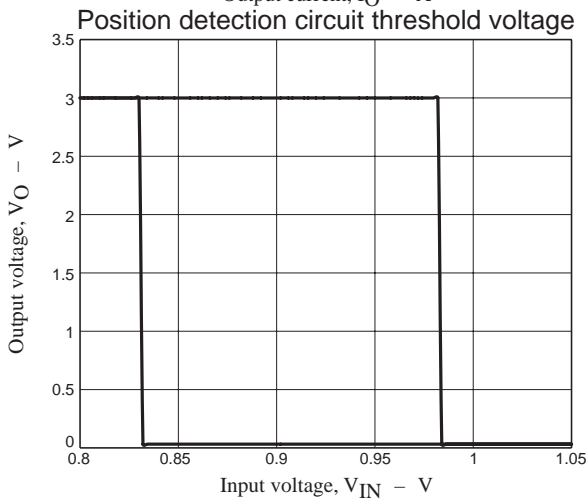
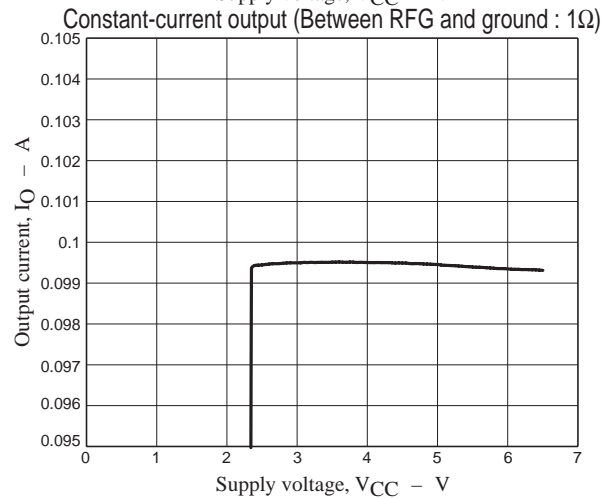
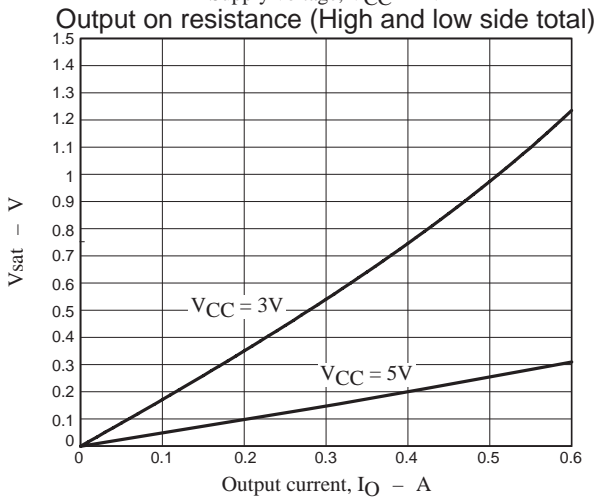
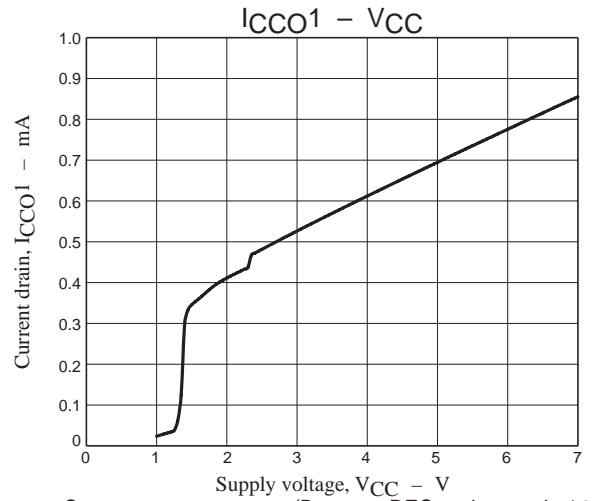
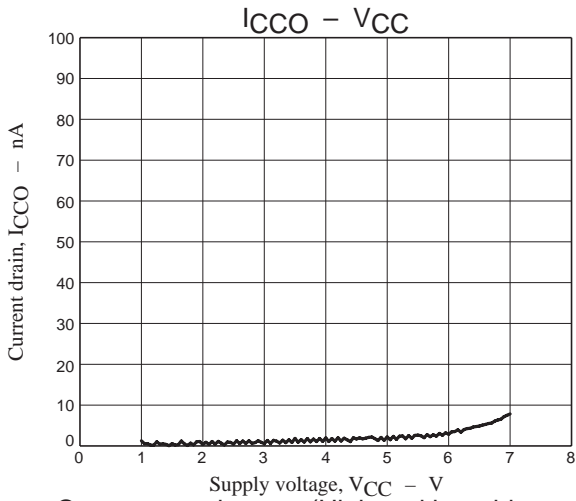

- SANYO Semiconductor Co.,Ltd. assumes no responsibility for equipment failures that result from using products at values that exceed, even momentarily, rated values (such as maximum ratings, operating condition ranges, or other parameters) listed in products specifications of any and all SANYO Semiconductor Co.,Ltd. products described or contained herein.
- SANYO Semiconductor Co.,Ltd. strives to supply high-quality high-reliability products, however, any and all semiconductor products fail or malfunction with some probability. It is possible that these probabilistic failures or malfunction could give rise to accidents or events that could endanger human lives, trouble that could give rise to smoke or fire, or accidents that could cause damage to other property. When designing equipment, adopt safety measures so that these kinds of accidents or events cannot occur. Such measures include but are not limited to protective circuits and error prevention circuits for safe design, redundant design, and structural design.
- In the event that any or all SANYO Semiconductor Co.,Ltd. products described or contained herein are controlled under any of applicable local export control laws and regulations, such products may require the export license from the authorities concerned in accordance with the above law.
- No part of this publication may be reproduced or transmitted in any form or by any means, electronic or mechanical, including photocopying and recording, or any information storage or retrieval system, or otherwise, without the prior written consent of SANYO Semiconductor Co.,Ltd.
- Any and all information described or contained herein are subject to change without notice due to product/technology improvement, etc. When designing equipment, refer to the "Delivery Specification" for the SANYO Semiconductor Co.,Ltd. product that you intend to use.
- Information (including circuit diagrams and circuit parameters) herein is for example only; it is not guaranteed for volume production.
- Upon using the technical information or products described herein, neither warranty nor license shall be granted with regard to intellectual property rights or any other rights of SANYO Semiconductor Co.,Ltd. or any third party. SANYO Semiconductor Co.,Ltd. shall not be liable for any claim or suits with regard to a third party's intellectual property rights which has resulted from the use of the technical information and products mentioned above.

This catalog provides information as of August, 2009. Specifications and information herein are subject to change without notice.