

FAST Products

FEATURES

- Code conversions
- Multi-channel D/A converter
- Decimal-to-BCD converter
- Cascading for priority encoding of "N" bits
- Input enable capability
- Priority encoding-automatic selection of highest priority input line
- Output enable-active Low when all inputs are High
- Group signal output-active when any input is Low

DESCRIPTION

The 74F148 8-input priority encoder accepts data from eight active-Low inputs and provides a binary representation on the three active-Low outputs. A priority is assigned to each input so that when two or more inputs are simultaneously active, the input with the highest priority is represented on the output, with input line I_7 having the highest priority. A High on the Enable Input (\overline{EI}) will force all outputs to the inactive (High) state and allow new data to settle without producing erroneous information at the outputs. A Group Signal (\overline{GS}) output and an Enable Output (\overline{EO}) are provided with the three data outputs. The \overline{GS} is active-Low when any

8-Input Priority Encoder

Product Specification

| TYPE | TYPICAL PROPAGATION DELAY | TYPICAL SUPPLY CURRENT (TOTAL) |
|--------|---------------------------|--------------------------------|
| 74F148 | 6.0ns | 23mA |

ORDERING INFORMATION

| PACKAGES | COMMERCIAL RANGE $V_{CC} = 5V \pm 10\%$; $T_A = 0^\circ C$ to $+70^\circ C$ |
|--------------------|---|
| 16-Pin Plastic DIP | N74F148N |
| 16-Pin Plastic SO | N74F148D |

INPUT AND OUTPUT LOADING AND FAN-OUT TABLE

| PINS | DESCRIPTION | 74F(U.L.) HIGH/LOW | LOAD VALUE HIGH/LOW |
|-----------------------------------|----------------------------------|--------------------|---------------------|
| $\overline{I}_1 - \overline{I}_7$ | Priority inputs (active Low) | 1.0/2.0 | 20 μ A/1.2mA |
| \overline{I}_0 | Priority input (active Low) | 1.0/1.0 | 20 μ A/0.6mA |
| \overline{EI} | Enable input (active Low) | 1.0/2.0 | 20 μ A/1.2mA |
| \overline{EO} | Enable output (active Low) | 50/33 | 1.0mA/20mA |
| \overline{GS} | Group select output (active Low) | 50/33 | 1.0mA/20mA |
| $\overline{A}_0 - \overline{A}_2$ | Address outputs (active Low) | 50/33 | 1.0mA/20mA |

NOTE:

One (1.0) FAST Unit Load is defined as: 20 μ A in the High state and 0.6mA in the Low state.

input is Low; this indicates when any input is active. The \overline{EO} is active-Low when all inputs are High. Using the Enable Output along with the Enable Input allows priority

encoding of N input signals. Both \overline{EO} and \overline{GS} are active-High when the Enable Input is High.

PIN CONFIGURATION

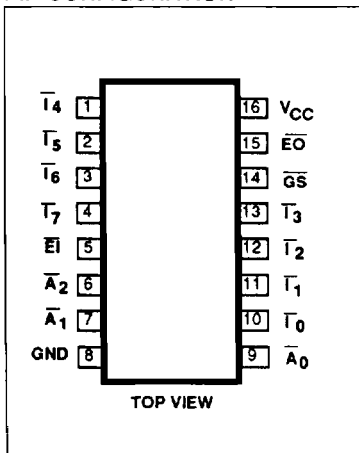

April 11, 1989

LOGIC SYMBOL

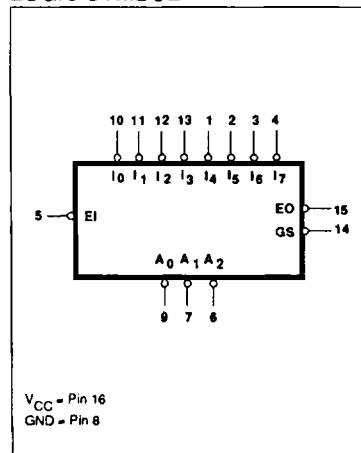

6-122

LOGIC SYMBOL (IEEE/IEC)

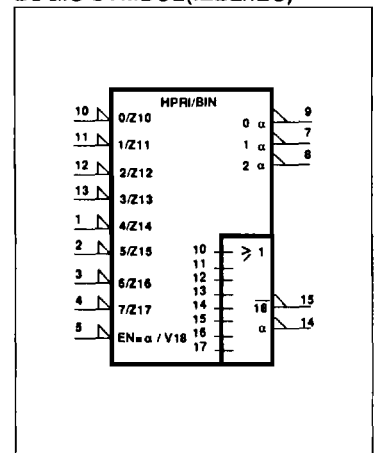

853-0345-96313

Encoder

FAST 74F148

LOGIC DIAGRAM

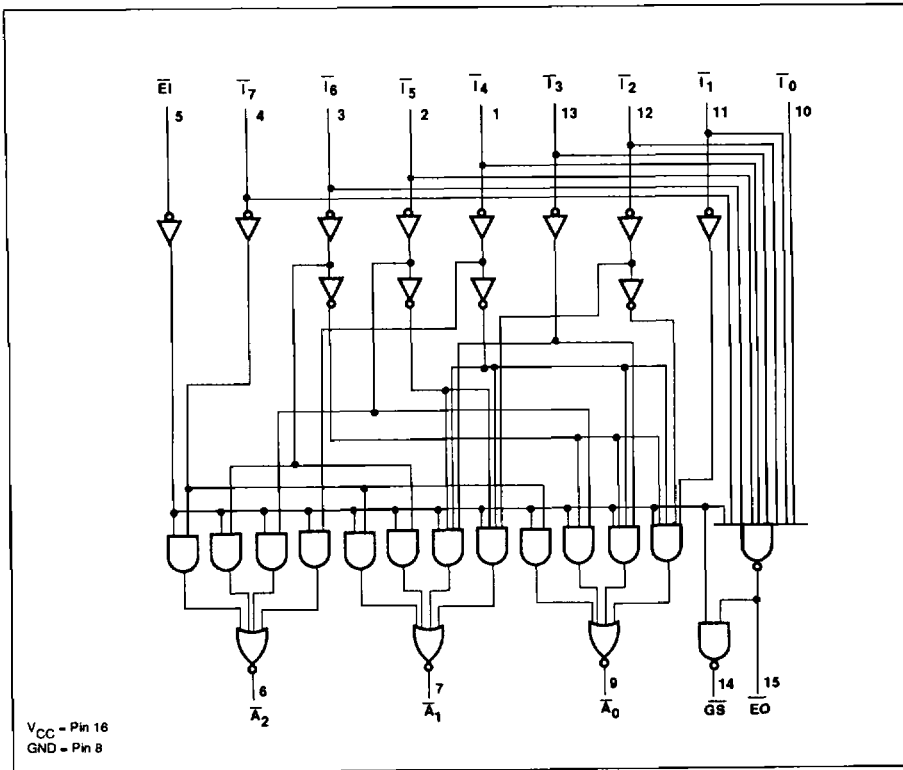

FUNCTION TABLE

| INPUTS | | | | | | | | OUTPUTS | | | | | |
|-------------|-------------|-------------|-------------|-------------|-------------|-------------|-------------|-------------|-------------|-------------|-------------|-------------|-------------|
| \bar{E}_i | \bar{I}_0 | \bar{I}_1 | \bar{I}_2 | \bar{I}_3 | \bar{I}_4 | \bar{I}_5 | \bar{I}_6 | \bar{I}_7 | \bar{G}_S | \bar{A}_0 | \bar{A}_1 | \bar{A}_2 | \bar{E}_O |
| H | X | X | X | X | X | X | X | X | H | H | H | H | H |
| L | H | H | H | H | H | H | H | H | H | H | H | H | L |
| L | X | X | X | X | X | X | X | L | L | L | L | L | H |
| L | X | X | X | X | X | L | H | H | L | H | L | L | H |
| L | X | X | X | X | L | H | H | H | L | H | H | L | H |
| L | X | X | X | L | H | H | H | H | L | L | L | H | H |
| L | X | X | L | H | H | H | H | H | L | H | L | H | H |
| L | X | L | H | H | H | H | H | H | L | L | H | H | H |
| L | L | H | H | H | H | H | H | H | L | H | H | H | H |

H = High voltage level
 L = Low voltage level
 X = Don't care

Encoder

FAST 74F148

APPLICATION

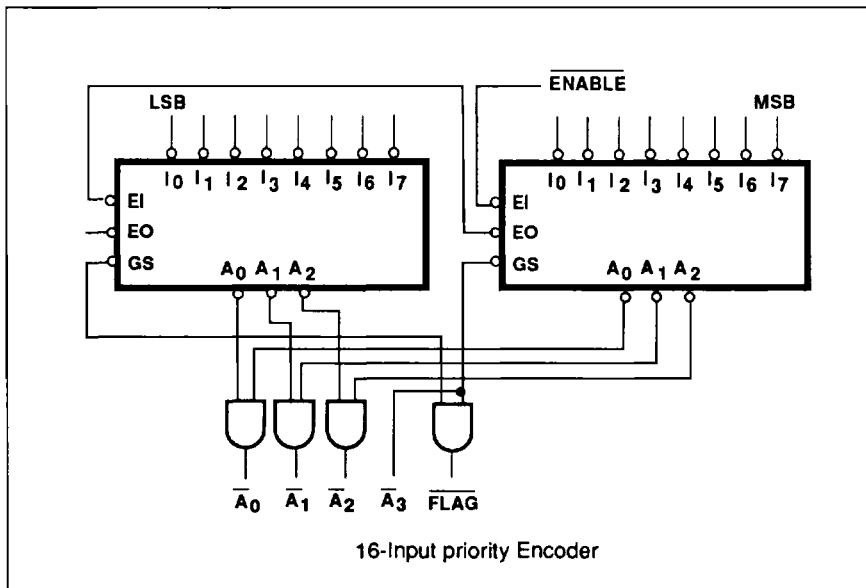

ABSOLUTE MAXIMUM RATINGS (Operation beyond the limits set forth in this table may impair the useful life of the device. Unless otherwise noted these limits are over the operating free-air temperature range.)

| SYMBOL | PARAMETER | RATING | UNIT |
|-----------|--|-------------------|------|
| V_{CC} | Supply voltage | -0.5 to +7.0 | V |
| V_{IN} | Input voltage | -0.5 to +7.0 | V |
| I_{IN} | Input current | -30 to +5 | mA |
| V_{OUT} | Voltage applied to output in High output state | -0.5 to $+V_{CC}$ | V |
| I_{OUT} | Current applied to output in Low output state | 40 | mA |
| T_A | Operating free-air temperature range | 0 to +70 | °C |
| T_{STG} | Storage temperature | -65 to +150 | °C |

RECOMMENDED OPERATING CONDITIONS

| SYMBOL | PARAMETER | LIMITS | | | UNIT |
|----------|--------------------------------------|--------|-----|-----|------|
| | | Min | Nom | Max | |
| V_{CC} | Supply voltage | 4.5 | 5.0 | 5.5 | V |
| V_{IH} | High-level input voltage | 2.0 | | | V |
| V_{IL} | Low-level input voltage | | | 0.8 | V |
| I_K | Input clamp current | | | -18 | mA |
| I_{OH} | High-level output current | | | -1 | mA |
| I_{OL} | Low-level output current | | | 20 | mA |
| T_A | Operating free-air temperature range | 0 | | 70 | °C |

Encoder

FAST 74F148

DC ELECTRICAL CHARACTERISTICS (Over recommended operating free-air temperature range unless otherwise noted.)

| SYMBOL | PARAMETER | TEST CONDITIONS ¹ | LIMITS | | | UNIT | |
|----------|---|--|------------------|------------------|------|---------|------|
| | | | Min | Typ ² | Max | | |
| V_{OH} | High-level output voltage | $V_{CC} = \text{MIN}, V_{IL} = \text{MAX}$ $V_{IH} = \text{MIN}, I_{OH} = \text{MAX}$ | $\pm 10\%V_{CC}$ | 2.5 | | V | |
| | | | $\pm 5\%V_{CC}$ | 2.7 | 3.4 | V | |
| V_{OL} | Low-level output voltage | $V_{CC} = \text{MIN}, V_{IL} = \text{MAX}$ $V_{IH} = \text{MIN}, I_{OL} = \text{MAX}$ | $\pm 10\%V_{CC}$ | | 0.30 | 0.50 | V |
| | | | $\pm 5\%V_{CC}$ | | 0.30 | 0.50 | V |
| V_{IK} | Input clamp voltage | $V_{CC} = \text{MIN}, I_I = I_{IK}$ | | -0.73 | -1.2 | V | |
| I_I | Input current at maximum input voltage | $V_{CC} = \text{MAX}, V_I = 7.0V$ | | | 100 | μA | |
| I_{IH} | High-level input current | $V_{CC} = \text{MAX}, V_I = 2.7V$ | | | 20 | μA | |
| I_{IL} | Low-level input current | $V_{CC} = \text{MAX}, V_I = 0.5V$ | I_0 | | | -0.6 | mA |
| | | | $I_1 - I_7, EI$ | | | | -1.2 |
| I_{OS} | Short-circuit output current ³ | $V_{CC} = \text{MAX}$ | | -60 | | -150 | mA |
| I_{CC} | Supply current (total) ⁴ | $V_{CC} = \text{MAX}$ | | 23 | 35 | mA | |

NOTES:

- For conditions shown as MIN or MAX, use the appropriate value specified under recommended operating conditions for the applicable type.
- All typical values are at $V_{CC} = 5V, T_A = 25^\circ C$.
- Not more than one output should be shorted at a time. For testing I_{OS} , the use of high-speed test apparatus and/or sample-and-hold techniques are preferable in order to minimize internal heating and more accurately reflect operational values. Otherwise, prolonged shorting of a High output may raise the chip temperature well above normal and thereby cause invalid readings in other parameter tests. In any sequence of parameter tests, I_{OS} tests should be performed last.
- To measure I_{CC} , outputs must be open, V_{IN} on all inputs=4.5V.

AC ELECTRICAL CHARACTERISTICS

| SYMBOL | PARAMETER | TEST CONDITION | LIMITS | | | | | UNIT |
|------------------------|---|----------------|---|------------|-------------|--|--------------|------|
| | | | $T_A = +25^\circ C$ $V_{CC} = 5V$ $C_L = 50pF$ $R_L = 500\Omega$ | | | $T_A = 0^\circ C \text{ to } +70^\circ C$ $V_{CC} = 5V \pm 10\%$ $C_L = 50pF$ $R_L = 500\Omega$ | | |
| | | | Min | Typ | Max | Min | Max | |
| t_{PLH} t_{PHL} | Propagation delay I_n to \bar{A}_n | Waveform 2 | 3.5 4.0 | 6.0 6.0 | 9.0 10.5 | 3.5 4.0 | 10.0 12.0 | ns |
| t_{PLH} t_{PHL} | Propagation delay I_n to $E\bar{O}$ | Waveform 1 | 2.0 2.5 | 3.5 4.5 | 6.5 7.5 | 2.0 2.5 | 7.5 8.5 | ns |
| t_{PLH} t_{PHL} | Propagation delay I_n to $\bar{G}S$ | Waveform 2 | 2.0 2.0 | 4.0 6.0 | 9.0 8.0 | 2.0 2.0 | 10.0 9.0 | ns |
| t_{PLH} t_{PHL} | Propagation delay EI to \bar{A}_n | Waveform 2 | 3.5 3.0 | 6.0 5.5 | 8.5 8.0 | 3.5 3.0 | 9.5 9.0 | ns |
| t_{PLH} t_{PHL} | Propagation delay EI to $\bar{G}S$ | Waveform 2 | 2.5 3.0 | 4.5 5.5 | 7.0 7.5 | 2.5 3.0 | 8.0 8.5 | ns |
| t_{PLH} t_{PHL} | Propagation delay EI to $E\bar{O}$ | Waveform 2 | 3.0 4.5 | 5.0 7.0 | 7.0 10.5 | 3.0 4.5 | 8.0 12.0 | ns |

Encoder

FAST 74F148

AC WAVEFORMS

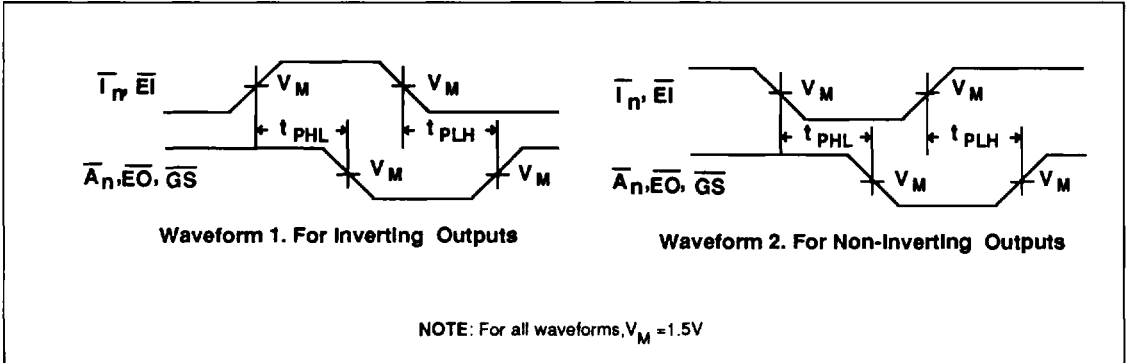

TEST CIRCUIT AND WAVEFORMS

