

23.5–26.5 GHz Surface Mount Medium Power Amplifier



AA026P2-A4

Patent Pending

Features

- Surface Mount Package
- 16 dB Gain
- 22 dBm $P_{1\text{ dB}}$ Output Power
- Single Voltage Operation
- 100% DC and RF Testing

Description

The AA026P2-A4 is a broadband millimeterwave medium power amplifier in a rugged surface mount package that is compatible with high-volume solder installation. The amplifier is designed for use in millimeterwave communication and sensor systems as an output stage or driver in the transmit chain or LO chain when high gain and high linearity is required. The robust ceramic surface mount package provides excellent electrical performance and a high degree of environmental protection for long-term reliability. All amplifiers are screened at the operating frequencies prior to shipment for guaranteed performance. Amplifier is targeted for high-volume millimeterwave applications such as point-to-point and point-to-multipoint wireless communications systems.

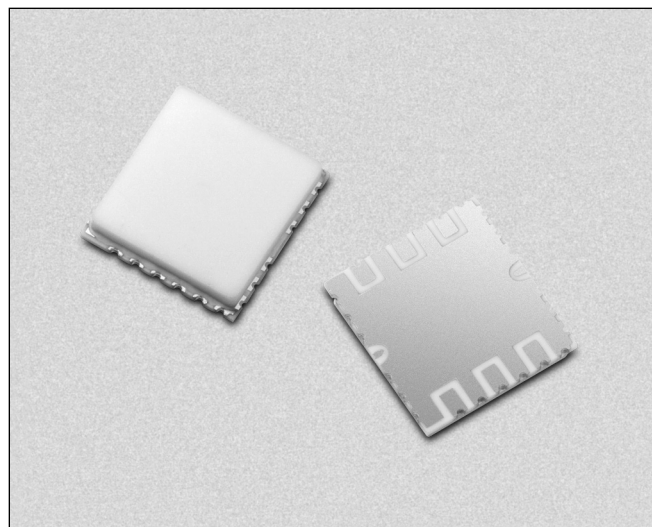

Pin Out

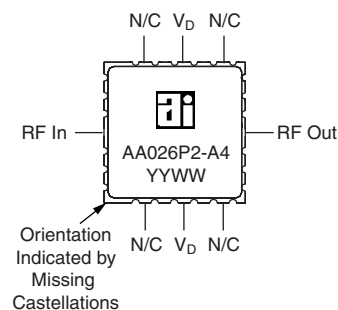

Electrical Specifications at 25°C ($V_D = 6\text{ V}$)

Parameter	Symbol	Min.	Typ.	Max.	Unit
Bandwidth	BW	23.5		26.5	GHz
Small Signal Gain ¹	G	14	16		dB
Output Power at 1 dB Gain Compression ²	$P_{1\text{ dB}}$	21	22		dBm
Input Return Loss ⁴	RL_I		9		dB
Output Return Loss ⁴	RL_O		9		dB
Temperature Coefficient of Gain ⁴	dG/dT		-0.03		dB/C
Drain Current ³	I_D		520	700	mA

1. Small signal gain over entire bandwidth is measured on 100% of parts.

2. Output power $P_{1\text{ dB}}$ is measured at 26.5 GHz on 100% of parts.

3. Drain current is measured on 100% of parts.

4. Not measured on 100% of parts.

Typical Performance Data ($V_D = 6\text{ V}$)

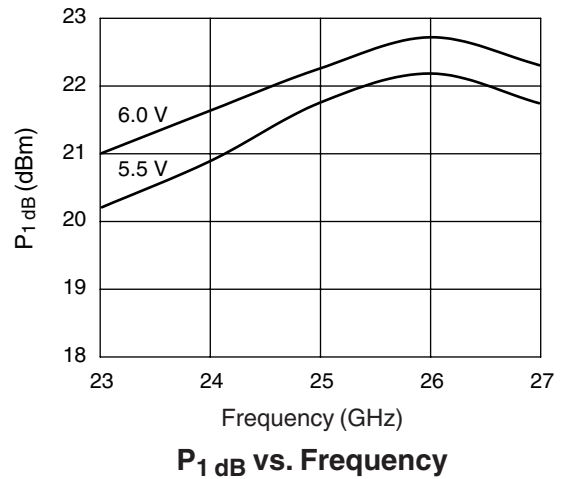
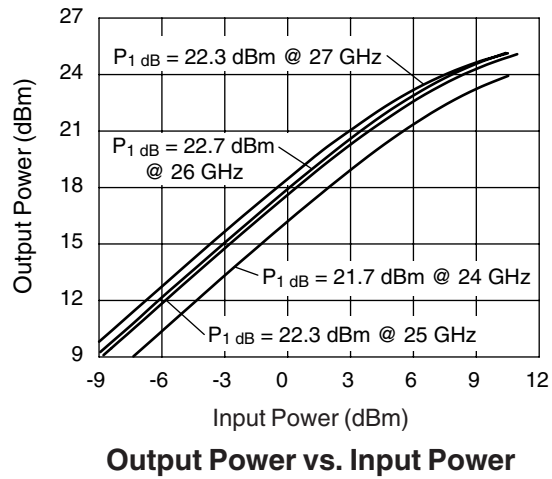
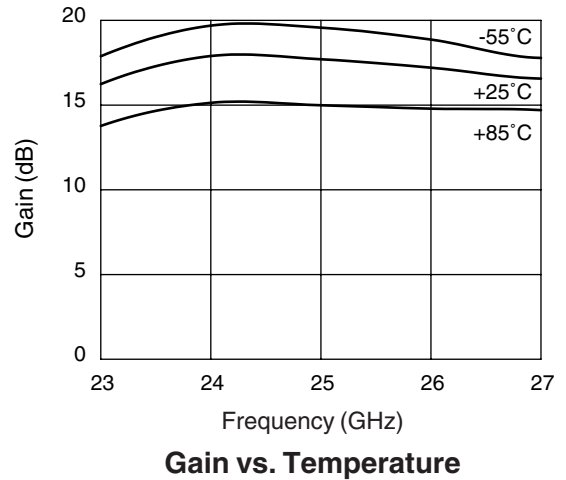
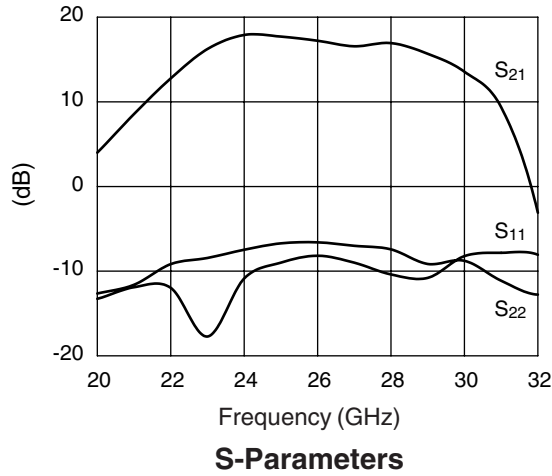

Outline Drawing

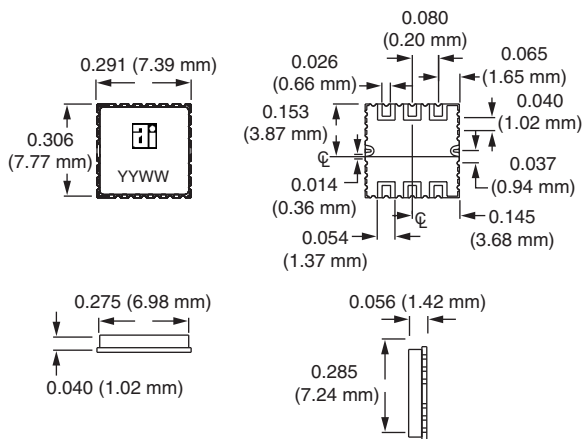

Absolute Maximum Ratings

Characteristic	Value
Operating Temperature (T_C)	-55°C to +85°C
Storage Temperature (T_{ST})	-65°C to +125°C
Bias Voltage (V_D)	7 V_{DC}
Power In (P_{IN})	22 dBm

Typical S-Parameters at 25°C ($V_D = 6\text{ V}$)

Frequency (GHz)	S ₁₁		S ₂₁		S ₁₂		S ₂₂	
	Mag. (dB)	Ang. (Deg.)	Mag. (dB)	Ang. (Deg.)	Mag. (dB)	Ang. (Deg.)	Mag. (dB)	Ang. (Deg.)
18	-16.6	-53	-4.4	-48	-48.6	48	-13.3	-117
19	-14.0	-67	-0.1	-100	-45.5	35	-13.6	-127
20	-13.3	-100	4.0	-155	-46.1	24	-12.6	-143
21	-11.9	-131	8.6	147	-46.3	9	-11.6	-150
22	-12.0	-142	12.8	77	-50.3	3	-9.2	-146
23	-17.7	-115	16.2	-1	-55.1	24	-8.4	-160
24	-10.9	-89	17.9	-83	-59.0	30	-7.5	-176
25	-9.0	-106	17.7	-163	-44.2	138	-6.7	171
26	-8.2	-100	17.2	121	-41.6	81	-6.6	164
27	-10.0	-94	16.6	47	-31.0	84	-7.0	178
28	-10.4	-113	16.9	-42	-32.8	-63	-7.4	159
29	-10.8	-87	15.7	-127	-43.5	-63	-9.2	178
30	-8.2	-75	13.6	139	-40.8	-18	-8.8	179
31	-7.8	-85	9.4	26	-46.4	-112	-11.1	165
32	-8.1	-96	-3.1	-112	-35.9	-175	-12.8	179
33	-11.2	-128	-27.1	-118	-38.7	120	-11.4	142
34	-7.0	-169	-38.0	83	-33.6	19	-10.4	84
36	-6.1	132	-30.7	-84	-34.9	-67	-19.7	27
38	-9.8	3	-30.6	-139	-36.1	155	-10.3	95
40	-19.0	37	-34.1	16	-33.6	54	-4.2	16

Alpha-2™ Surface Mount Package Handling and Mounting

Millimeterwave components require careful mounting design to maintain optimal performance. The Alpha-2™ surface mount package (patent pending) provides a rugged and repeatable electrical connection using standard solder techniques.

The -A4 package is one of several parts in the Alpha-2™ surface mount package family.

Handling

The -A4 surface mount package is very rugged. However, due to ceramic's brittle nature, one should exercise care when handling with metal tools. Do not apply heavy pressure to the lid. Vacuum tools may be used to pick and place this part.

Only personnel trained in both ESD precautions and handling precautions should be allowed to handle these packages.

Package Construction

The -A4 surface mount package consists of a base and a lid. The package base is ceramic with filled vias and plated castellations. The package lid is unplated alumina. The lid seal is epoxy.

Mounting Design

The -A4 surface mount package is installed on top of a printed circuit board on a specially designed footprint.

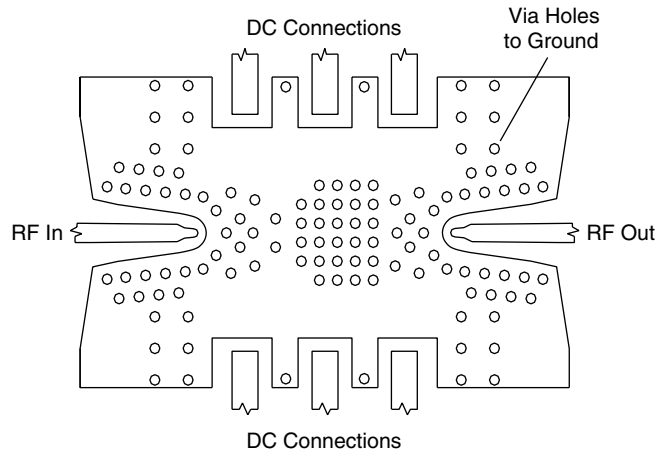

Footprint Geometry for -A4 Surface Mount Package.

Mounting footprint geometry for the -A4 package will be supplied by Skyworks in electronic format upon request.

Mounting the Package

The -A4 surface mount package is compatible with high-volume surface mount installation using solder. RF and DC connections are accomplished with metallized edge castellations that hold solder fillets. Ground connections are accomplished by both metallized edge castellations and filled vias to the bottom of the package. Care should be taken to ensure that there are no voids or gaps in the solder so that good RF, DC and ground contact is maintained.

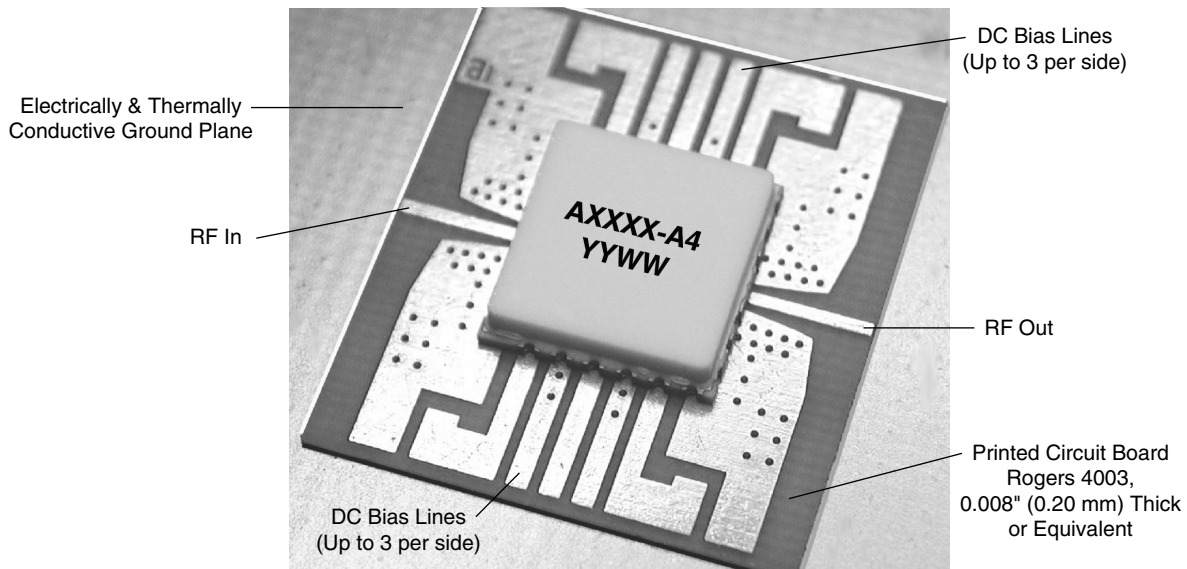

-A4 Surface Mount Package Installation.