

LVDT signal conditioner

NE/SA/SE5521

DESCRIPTION

The NE/SA/SE5521 is a signal conditioning circuit for use with Linear Variable Differential Transformers (LVDTs) and Rotary Variable Differential Transformers (RVDTs). The chip includes a low distortion, amplitude-stable sine wave oscillator with programmable frequency to drive the primary of the LVDT/RVDT, a synchronous demodulator to convert the LVDT/RVDT output amplitude and phase to position information, and an output amplifier to provide amplification and filtering of the demodulated signal.

FEATURES

- Low distortion
- Single supply 5V to 20V, or dual supply $\pm 2.5V$ to $\pm 10V$
- Oscillator frequency 1kHz to 20kHz
- Capable of ratiometric operation
- Low power consumption (182mV typ)

APPLICATIONS

- LVDT signal conditioning
- RVDT signal conditioning
- LPDT signal conditioning
- Bridge circuits

PIN CONFIGURATIONS

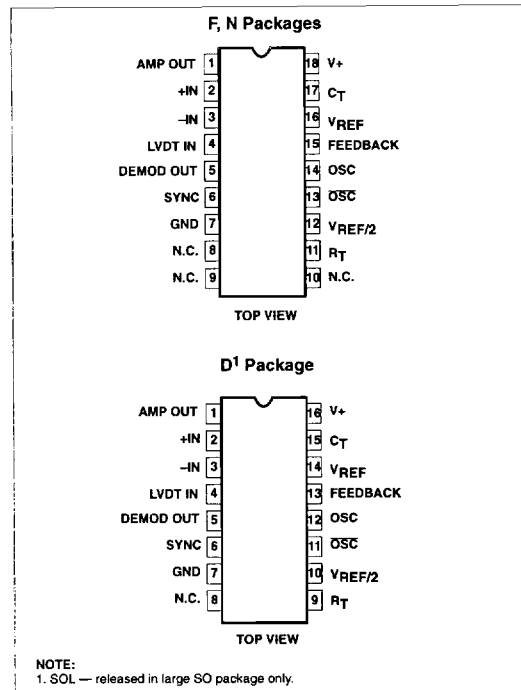

ORDERING INFORMATION

DESCRIPTION	TEMPERATURE RANGE	ORDER CODE	DWG #
18-Pin Plastic Dual In-Line Package (DIP)	0 to +70°C	NE5521N	0407A
16-Pin Small Outline Large (SOL) Package	0 to +70°C	NE5521D	0171B
18-Pin Plastic Dual In-Line Package (DIP)	-40 to +85°C	SA5521N	0407A
18-Pin Ceramic Dual In-Line Package (CERDIP)	-55 to +125°C	SE5521F	0583A
16-Pin Ceramic Dual In-Line Package (CERDIP)	-40 to +85°C	SA5521D	0582B

ABSOLUTE MAXIMUM RATINGS

SYMBOL	PARAMETER	RATING	UNIT
V _{CC}	Supply voltage	+20	V
	Split supply voltage	±10	V
T _A	Operating temperature range	0 to 70	°C
	NE5521	-40 to +85	°C
	SA5521 SE5521	-55 to +125	°C
T _{STG}	Storage temperature range	-65 to +125	°C
P _D	Power dissipation ¹	910	mW

NOTES:

1. For derating, see typical power dissipation versus load curves (Figure 1).

LVDT signal conditioner

NE/SA/SE5521

BLOCK DIAGRAM

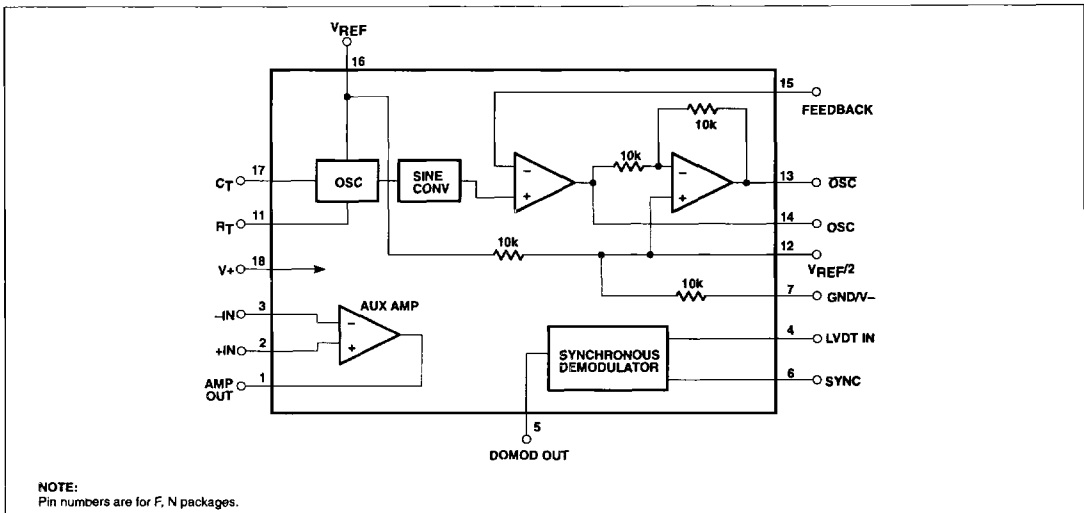

PIN DEFINITIONS FOR D, F AND N PACKAGES

PIN NO.		SYMBOL	DEFINITION
D	F, N		
1	1	Amp Out	Auxiliary Amplifier Out.
2	2	+IN	Auxiliary Amplifier non-inverting input.
3	3	-IN	Auxiliary Amplifier inverting input.
4	4	LVDT IN	Input to Synchronous Demodulator from the LVDT/RVDT secondary.
5	5	DEMOD OUT	Pulsating DC output from the Synchronous Demodulator output. This voltage should be filtered before use.
6	6	SYNC	Synchronizing input for the Synchronizing Demodulator. This input should be connected to the OSC or OSC output. Sync is referenced to V _{REF} /2.
7	7	GND	Device return. Should be connected to system ground or to the negative supply.
8	8	NC	No internal connection.
--	9	NC	No internal connection.
--	10	NC	No internal connection.
9	11	R _T	A temperature stable 18kΩ resistor should be connected between this pin and Pin 7.
10	12	V _{REF} /2	A high impedance source of one half the potential applied to V _{REF} . The LVDT/RVDT secondary return should be to this point. A bypass capacitor with low impedance at the oscillator frequency should also be connected between this pin and ground.
11	13	OSC	Oscillator sine wave output that is 180° out of phase with the OSC signal. The LVDT/RVDT primary is usually connected between OSC and OSC pins.
12	14	OSC	Oscillator sine wave output. The LVDT/RVDT primaries are usually connected between OSC and OSC pins.
13	15	FEEDBACK	Usually connected to the OSC output for unity gain, a resistor between this pin and OSC, and one between this pin and ground can provide for a change in the oscillator output pin amplitudes.
14	16	V _{REF}	Reference voltage input for the oscillator and sine converter. This voltage MUST be stable and must not exceed +V supply voltage.
15	17	C _T	Oscillator frequency-determining capacitor. The capacitor connected between this pin and ground should be a temperature-stable type.
16	18	+V	Positive supply connection.

LVDT signal conditioner

NE/SA/SE5521

DC ELECTRICAL CHARACTERISTICS

$V_+ = V_{REF} = 10V$, $T_A = 0$ to $70^\circ C$ for NE5521, $T_A = -55$ to $+125^\circ C$ for SE5521, $T_A = -40$ to $85^\circ C$ for SA5521, Frequency = 1kHz, unless otherwise noted.

SYMBOL	PARAMETER	TEST CONDITIONS	NE5521			SA/SE5521			UNIT
			Min	Typ	Max	Min	Typ	Max	
V_{CC}	Supply current			12.9	20		12.9	18	mA
I_{REF}	Reference current			5.3	8		5.3	8	mA
V_{REF}	Reference voltage range		5		V_+	5		V_+	V
P_D	Power dissipation			182	280		182	260	mW
Oscillator Section									
	Oscillator output	$R_L = 10k\Omega$	$\frac{V_{REF}}{8.8}$				$\frac{V_{REF}}{8.8}$		V_{RMS}
THD	Sine wave distortion	No load		1.5			1.5		%
	Initial amplitude error	$T_A = 25^\circ C$		0.4	± 3		0.4	± 3	%
	Tempco of amplitude			0.005	0.01		0.005	0.01	$\%/^\circ C$
	Init. accuracy of oscillator freq.	$T_A = 25^\circ C$		± 0.9	± 5		± 0.9	± 5	%
	Temperature coeff. of frequency ¹			0.05			0.05		$\%/^\circ C$
	Voltage coeff. of frequency			2.5			3.3		$\%/V(V_{REF})$
	Min OSC (OSC) Load ²		300	170		300	170		Ω
Demodulator Section									
ϵ_r	Linearity error	$5V_{P-P}$ input		± 0.05	± 0.1		± 0.05	± 0.1	%FS
	Maximum demodulator input			$\frac{V_{REF}}{2}$			$\frac{V_{REF}}{2}$		V_{P-P}
V_{OS}	Demodulator offset voltage			± 1.4	± 5		± 1.4	± 5	mV
TCV_{OS}	Demodulator offset voltage drift			5	25		5	25	$\mu V/^\circ C$
I_{BIAS}	Demodulator input current		-600	-234		-500	-234		nA
	$V_{R/2}$ accuracy			± 0.1	± 1		± 0.1	± 1	%
Auxiliary Output Amplifier									
V_{OS}	Input offset voltage			± 0.5	± 5		± 0.5	± 5	mV
I_{BIAS}	Input bias current		-600	-210		-500	-210		nA
I_{OS}	Input offset current			10	50		10	50	nA
A_V	Gain		100	385		100	385		V/mV
SR	Slew rate			1.3			1.3		V/ μs
GBW	Unity gain bandwidth product	$A_V = 1$		1.6			1.6		MHz
	Output voltage swing	$R_L = 10k\Omega$	7	8.2		7	8.2		V
	Output short circuit current to ground or to V_{CC}	$T_A = 25^\circ C$		42	100		42	100	mA

NOTES:

1. This is temperature coefficient of frequency for the device only. It is assumed that C_T and R_T are fixed in value and C_T leakage is fixed over the operating temperature range.
2. Minimum load impedance for which distortion is guaranteed to be less than 5%.

LVDT signal conditioner

NE/SA/SE5521

DEFINITION OF TERMS

Oscillator Output	RMS value of the AC voltage at the oscillator output pin. This output is referenced to $V_{REF/2}$ and is a function of V_{REF} .
Sine Wave Distortion	The Total Harmonic Distortion (THD) of the oscillator output with no load. This is not a critical specification in LVDT/RVDT systems. This figure could be 15% or more without affecting system performance.
Initial Amplitude Error	A measure of the interchangeability of NE/SA/SE5521 parts, not a characteristic of any one part. It is the degree to which the oscillator output of a number of NE/SA/SE5521 samples will vary from the median of that sample.
Initial Accuracy of Oscillator Frequency	Another measure of the interchangeability of individual NE/SA/SE5521 parts. This is the degree to which the oscillator frequency of a number of NE/SA/SE5521 samples will vary from the median of that sample with a given timing capacitor.
Tempco of Oscillator Amplitude	A measure of how the oscillator amplitude varies with ambient temperature as that temperature deviates from a 25°C ambient.
Tempco of Oscillator Frequency	A measure of how the oscillator frequency varies with ambient temperature as that temperature deviates from a 25°C ambient.
Voltage Coefficient of Oscillator Frequency	The degree to which the oscillator frequency will vary as the reference voltage (V_{REF}) deviates from +10V.
Min OSC (OSC) Load	Minimum load impedance for which distortion is guaranteed to be less than 5%.
Linearity Error	The degree to which the DC output of the demodulator/amplifier combination matches a change in the AC signal at the demodulator input. It is measured as the worst case nonlinearity from a straight line drawn between positive and negative fullscale end points.
Maximum Demodulator Input	The maximum signal that can be applied to the demodulator input without exceeding the specified linearity error.

APPLICATION INFORMATION

$$\text{OSC frequency} = \frac{V_{REF} - 1.3V}{V_{REF} (R_T + 1.5k) C_T}$$

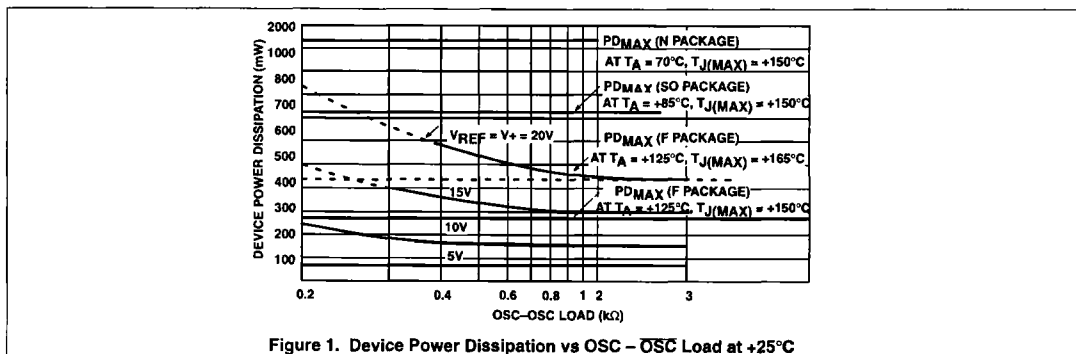

Figure 1. Device Power Dissipation vs OSC - OSC Load at +25°C

LVDT signal conditioner

NE/SA/SE5521

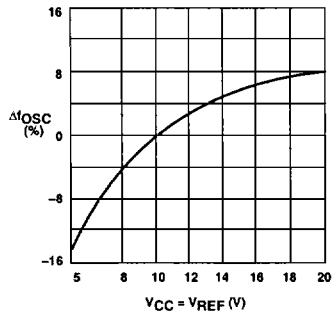

Figure 2. Oscillator Frequency Variation With Voltage (Normalized to V_{REF} = V_{CC} = 10V) T_A = +25°C

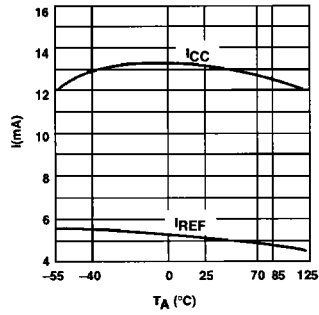

Figure 4. I_{REF} and I_{CC} vs Temperature (V_{REF} = V_{CC} = 10V)

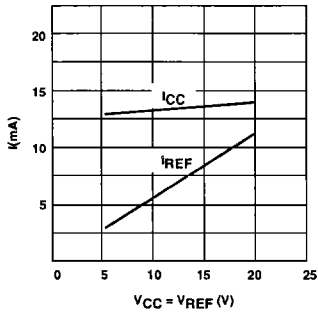

Figure 3. I_{REF} and I_{CC} vs Voltage (T_A = +25°C)