

---

# MT-RJ Duplex Single Mode Transceiver

## Technical Data

### Features

- **MT-RJ Duplex Single Mode Transceiver**
- **Intermediate SONET OC3 SDH STM1 (S1.1) Compliant**
- **Single +3.3 V Power Supply**
- **Multisourced 2 x 5 Pin Configuration**
- **Interchangeable with LED Multisourced 2 x 5 Transceivers**
- **Unconditionally Eyesafe Laser IEC 825/CDRH Class 1 Compliant**
- **Temperature Range: 0°C to +70°C**

### Applications

- **SONET/SDH Equipment Interconnect**
- **ATM 155 Mb/s Links**

### Description

The HFCT-5905E transceiver is a high performance, cost effective module for serial optical data communications applications specified for a signal rate of 155 MBd. It is designed to provide a SONET/SDH compliant link for 155 Mb/s intermediate reach links. The HFCT-5905 does not include a nose shield and is not recommended due to the potential degradation of EMI performance in a complete system. The HFCT-5905 is available on the rare occasion that a system mechanical design may not allow for a nose shield.

This module is designed for single mode fiber and operates at a nominal wavelength of 1300 nm. It incorporates Hewlett-Packard's high performance, reliable, long wavelength optical devices and proven circuit technology to give long life and consistent service.

---

### HFCT-5905E

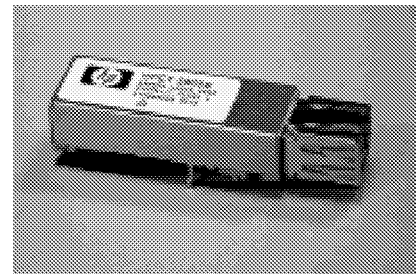

The transmitter section uses an advanced SMQW Fabry Perot laser with full IEC 825 and CDRH Class I eye safety.

The receiver section uses a MOVPE grown planar PIN photodetector for low dark current and excellent responsivity.

A pseudo-ECL logic interface simplifies interface to external circuitry.

## Connection Diagram

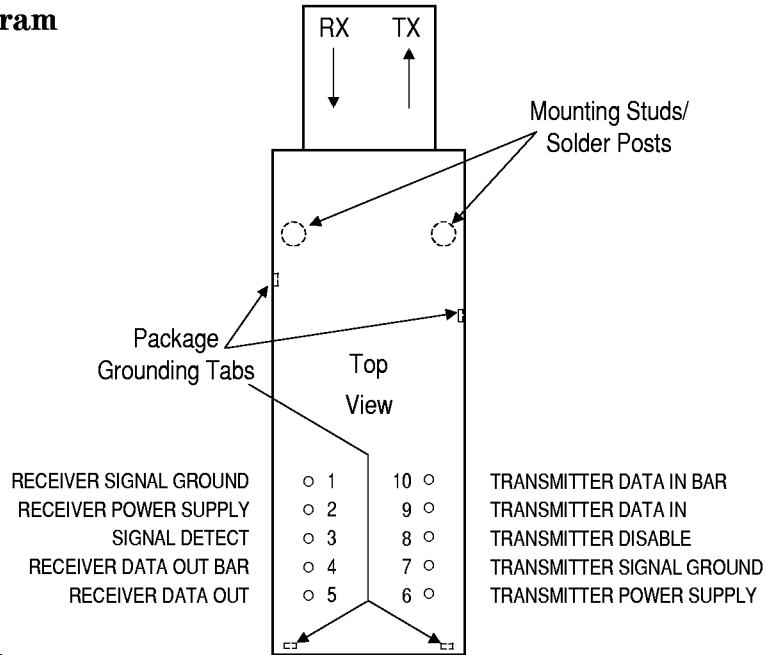

## Pin Descriptions:

### Pin 1 Receiver Signal Ground $V_{EE} \text{ RX}$ :<sup>1</sup>

Directly connect this pin to the receiver ground plane.

### Pin 2 Receiver Power Supply $V_{CC} \text{ RX}$ :

Provide +3.3 V dc via the recommended receiver power supply filter circuit. Locate the power supply filter circuit as close as possible to the  $V_{CC} \text{ RX}$  pin.

### Pin 3 Signal Detect $SD$ :

Normal optical input levels to the receiver result in a logic “1” output.

Low optical input levels to the receiver result in a fault condition indicated by a logic “0” output.

This Signal Detect output can be used to drive a PECL input on an upstream circuit, such as Signal Detect input or Loss of Signal-bar.

### Pin 4 Receiver Data Out Bar $RD-$ :

No internal terminations are provided. See recommended circuit schematic.

### Pin 5 Receiver Data Out $RD+$ :

No internal terminations are provided. See recommended circuit schematic.

### Pin 6 Transmitter Power Supply $V_{CC} \text{ TX}$ :

Provide +3.3 V dc via the recommended transmitter power supply filter circuit. Locate the power supply filter circuit as close as possible to the  $V_{CC} \text{ TX}$  pin.

### Pin 7 Transmitter Signal Ground $V_{EE} \text{ TX}$ :

Directly connect this pin to the transmitter ground plane.

### Pin 8 Transmitter Disable $T_{DIS}$ :

Optional feature for laser based products only. For laser based products connect this pin to +3.3 V TTL logic high “1” to disable module. To enable module connect to TTL logic low “0”.

### Pin 9 Transmitter Data In $TD+$ :

No internal terminations are provided. See recommended circuit schematic.

### Pin 10 Transmitter Data In Bar $TD-$ :

No internal terminations are provided. See recommended circuit schematic.

### Mounting Studs/Solder Posts

The two mounting studs are provided for transceiver mechanical attachment to the circuit board. It is recommended that the holes in the circuit board be connected to chassis ground.

### Package Grounding Tabs

Connect four package grounding tabs to signal ground.

**Note:** 1. The Transmitter and Receiver  $V_{EE}$  connections are commoned within the module.

## Functional Description Receiver Section

### Design

The receiver section contains an InGaAs/InP photo detector and a preamplifier mounted in an optical subassembly. This optical subassembly is coupled to a postamp/decision circuit on a separate circuit board.

The postamplifier is ac coupled to the preamplifier as illustrated in Figure 1. The coupling capacitors are large enough to pass the SONET/SDH test pattern at 155 MBd without significant distortion or performance penalty. If a lower signal rate, or a code which has significantly more low frequency content is used, sensitivity, jitter and pulse distortion could be degraded.

Figure 1 also shows a filter network which limits the bandwidth of the preamp output signal. The filter is designed to bandlimit the preamp output noise and thus improve the receiver sensitivity.

These components will also reduce the sensitivity of the receiver as the signal bit rate is increased above 155 MBd.

### Noise Immunity

The receiver includes internal circuit components to filter power supply noise. Under some conditions of EMI and power supply noise, external power supply filtering may be necessary. If receiver sensitivity is found to be degraded by power supply noise, the filter network illustrated in Figure 3 may be used to improve performance. The values of the filter components are general recommendations and may be changed to suit a particular system environment. Shielded inductors are recommended.

### Terminating the Outputs

The PECL Data outputs of the receiver may be terminated with the standard Thevenin-equivalent 50 ohm to  $V_{CC} - 2\text{ V}$  termination. Other standard PECL terminating techniques may be used.

The two outputs of the receiver should be terminated with identical load circuits to avoid unnecessarily large ac current in  $V_{CC}$ . If the outputs are loaded identically the ac current is largely nulled. The SD output of the receiver is PECL logic and must be loaded if it is to be used. The signal detect circuit is much slower than the data path, so the ac noise generated by an asymmetrical load is negligible. Power consumption may be reduced by using a higher than normal load impedance for the SD output. Transmission line effects are not generally a problem as the switching rate is slow.

### The Signal Detect Circuit

The signal detect circuit works by sensing the peak level of the received signal and comparing this level to a reference.

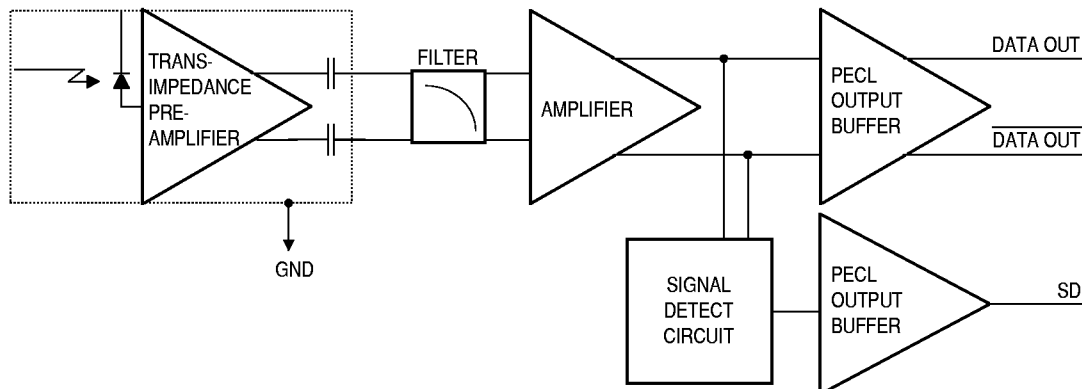

Figure 1. Receiver Block Diagram

## Functional Description Transmitter Section

### Design

The transmitter section uses a buried heterostructure Fabry Perot laser as its optical source. The package of this laser is designed to allow repeatable coupling into single mode fiber. In addition, this package has been designed to be compliant with IEC 825 Class 1 and CDRH Class I eye safety requirements. The optical output is controlled by a custom IC which detects the laser output via the monitor photodiode. This IC provides both dc and ac current drive to the laser to ensure correct modulation, eye diagram and extinction ratio over temperature, supply voltage and life.

### Solder and Wash Process Compatibility

The transceivers are delivered with protective process plugs inserted into the MT-RJ connector receptacle. This process plug protects the optical subassemblies during wave solder and aqueous wash processing and acts as a dust cover during shipping.

These transceivers are compatible with either industry standard wave or hand solder processes. Each process plug can only be used once during processing, although with subsequent use, it can be used as a dust cover.

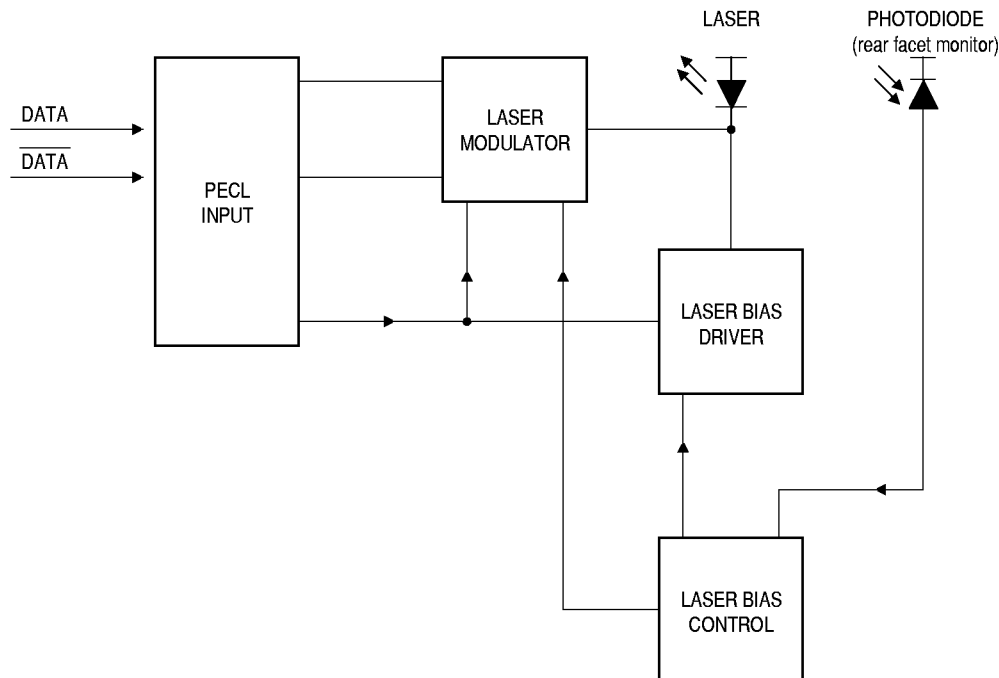

Figure 2. Simplified Transmitter Schematic



<b>Regulatory Compliance</b>		
<b>Feature</b>	<b>Test Method</b>	<b>Targeted Performance</b>
Electrostatic Discharge (ESD) to the Electrical Pins	MIL-STD-883C Method 3015.4	Meets Class 1 (2000 Volts).
Electrostatic Discharge (ESD) to the Duplex MT-RJ Receptacle	Variation of IEC 801-2	Products of this type, typically, withstand at least 25 kV without damage when the Duplex MT-RJ Connector Receptacle is contacted by a Human Body Model probe.
Electromagnetic Interference (EMI)	FCC Class B CENELEC EN55022 Class B (CISPR 22A) VCCI Class 1	Transceivers typically provide 2 dB margin to the noted standard limits when tested at a certified test range with the transceiver mounted to a circuit card without a chassis enclosure. Three transceivers typically provide 20 dB of margin in a 'perfect' closed box with the recommended port openings.
Immunity	Variation of IEC 801-3	Typically show no measurable effect from a 10 V/m field swept from 10 to 450 MHz applied to the transceiver when mounted to a circuit card without a chassis enclosure.
Eye Safety	FDA CDRH 21-CFR 1040 Class 1	Compliant per Hewlett-Packard testing under normal operating conditions. Accession Number: 9521220-20.
	IEC 825 Issue 1 1993:11 Class 1 CENELEC EN60825 Class 1	Compliant per Hewlett-Packard testing under single fault conditions. TUV Certification: 933/510817/05.

## Performance Specifications

### Absolute Maximum Ratings

Parameter	Symbol	Minimum	Typical	Maximum	Units	Notes
Storage Temperature	$T_S$	-40		+85	°C	
Lead Soldering Temperature/Time	$T_{SOLD} / t_{SOLD}$			+260/10	°C/s	
Output Current	$I_O$	0		30	mA	
Data Input Voltage	$V_I$	GND		$V_{CC}$	V	
Power Supply Voltage	$V_{CC}$	0		+3.6	V	

### Operating Environment

Parameter	Symbol	Minimum	Typical	Maximum	Units	Notes
Ambient Operating Temperature	$T_A$	0		+70	°C	
Power Supply Voltage	$V_{CC}$	3.10		3.50	V	
Data Input Voltage - Low	$V_{IL} - V_{CC}$	-1.810		-1.475	V	
Data Input Voltage - High	$V_{IH} - V_{CC}$	-1.165		-0.880	V	
Data and Signal Detect Output Load	$R_L$		50		$\Omega$	1

### Transmitter Section

(Ambient Operating Temperature  $V_{CC} = 3.1 \text{ V to } 3.5 \text{ V}$ )

Parameter	Symbol	Minimum	Typical	Maximum	Units	Notes
Supply Current	$I_{CC}$		50	120	mA	2
Power Dissipation	$P_{DISS}$		0.175	0.42	W	
Optical Output Power	$P_O$	-15		-8.0	dBm avg.	3
Center Wavelength	$\lambda_C$	1261		1360	nm	
Spectral Width	$\Delta\lambda$	-		7.7	nm	
Extinction Ratio	$E_R$	8.2		-	dB	
Output Optical Eye	Compliant with Eye Mask Bellcore TR-NWT-000253 and ITU recommendation G.957					
Optical Rise Time	$t_R$	-		2	ns	4
Optical Fall Time	$t_F$	-		2	ns	4
Data Input Current - Low	$I_{IL}$	-200		-	$\mu\text{A}$	
Data Input Current - High	$I_{IH}$	-		200	$\mu\text{A}$	
Data Input Voltage - Low	$V_{IL} - V_{CC}$	-1.810		-1.475	V	5
Data Input Voltage - High	$V_{IH} - V_{CC}$	-1.165		-0.880	V	5

#### Notes:

- Outputs terminated with  $50 \Omega$  to  $V_{CC} - 2\text{V}$  are the Thevenin equivalent.
- The power supply current varies with temperature. Maximum current is specified at  $V_{CC} = \text{Maximum}$  @ maximum temperature (not including terminations) and end of life.
- Output power is power coupled into a single mode fiber.
- 10% - 90% Values
- These inputs are compatible with 10 K, 10 KH, and 100 K ECL and LVPECL inputs.

## Receiver Section

(Ambient Operating Temperature  $V_{CC} = 3.1 \text{ V to } 3.5 \text{ V}$ )

Parameter	Symbol	Minimum	Typical	Maximum	Units	Notes
Supply Current	$I_{CC}$		75	100	mA	6
Power Dissipation	$P_{DISS}$		0.263	0.35	W	7
Receiver Sensitivity at Eye Center	$P_{IN \text{ Min. (C)}}$			-31.8	dBm avg.	8
Receiver Sensitivity at Window Edge	$P_{IN \text{ Min. (W)}}$			-31	dBm avg.	8
Maximum Input Optical Power	$P_{IN \text{ Max.}}$	-8.0		-	dBm avg.	8
Operating Wavelength	$\lambda$	1261		1360	nm	
Data Output Voltage - Low	$V_{OL} - V_{CC}$	-1.840		-1.620	V	9
Data Output Voltage - High	$V_{OH} - V_{CC}$	-1.045		-0.880	V	9
Signal Detect Output Voltage - Low	$V_{OL} - V_{CC}$	-1.840		-1.620	V	9
Signal Detect Output Voltage - High	$V_{OH} - V_{CC}$	-1.045		-0.880	V	9
Signal Detect - Asserted	$P_A$	$P_D + 1.5 \text{ dB}$		-34	dBm avg.	
Signal Detect - Deasserted	$P_D$	-45			dBm avg.	
Signal Detect - Hysteresis	$P_A - P_D$	0.5		4.0	dB	
Signal Detect Assert time (off to on)	AS_Max	0		100	$\mu\text{S}$	
Signal Detect Deassert time (on to off)	ANS_Max	0		350	$\mu\text{S}$	
Power Supply Noise Rejection	PSNR			50	mV p-p	10

### Notes:

6. This does not include the output load current.
7. This does not include the output load power.
8. Minimum sensitivity and saturation levels for a 2<sup>23</sup>-1 PRBS with 72 ones and 72 zeros inserted. (CCITT recommendation G.958)
9. These outputs are compatible with 10 K, 10 KH and 100 K ECL and PECL outputs.
10. Between 20 Hz and 2000 KHz with the recommended power supply filter. No degradation above the maximum 'receiver sensitivity at eye center' specification of -31.8 dBm.

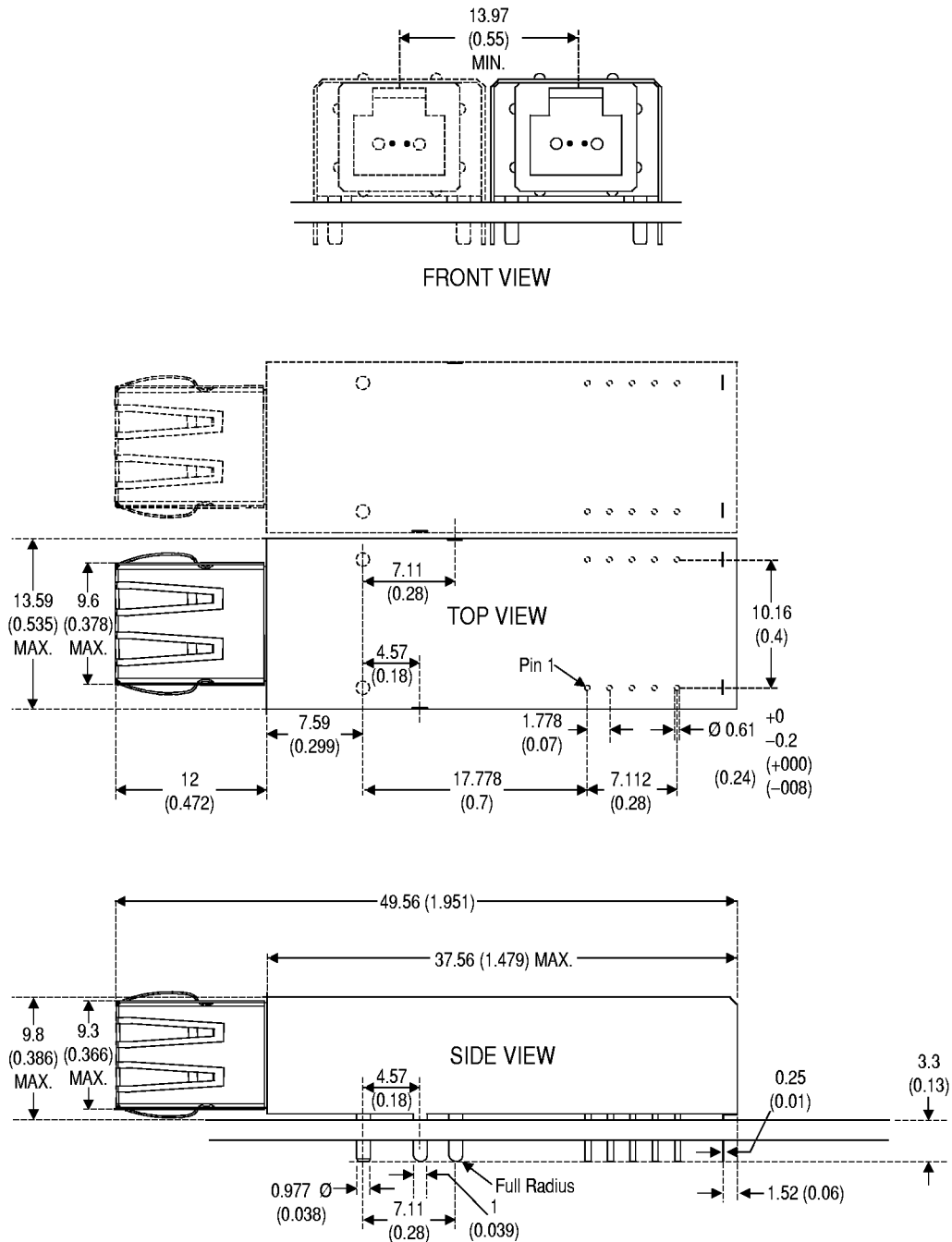

DIMENSIONS IN MILLIMETERS (INCHES)

**Notes:**

1. This page describes the maximum package outline, mounting studs, pins and their relationships to each other.
2. Toleranced to accommodate round or rectangular leads.
3. The 10 I/O pins, 2 solder posts and 4 package grounding tabs are to be treated as a single pattern. (see Figure 6 PCB layout)
4. The MT-RJ has a 750  $\mu$ m fiber spacing.
5. The MT-RJ alignment pins are in the module.
6. See MT-RJ Transceiver Pin Out Diagram for details.

**Figure 4. HFCT-5905E Package Outline Drawing**

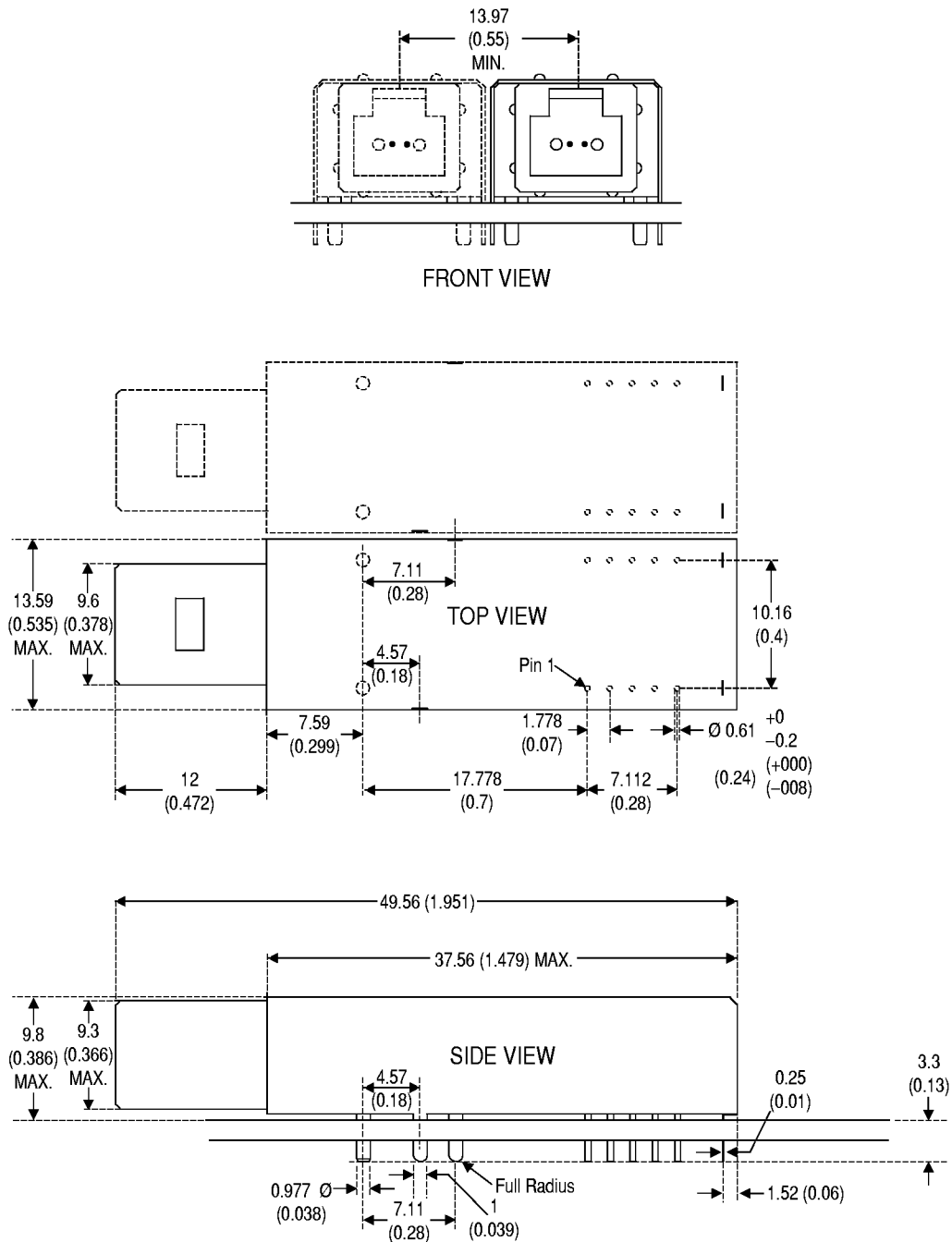

DIMENSIONS IN MILLIMETERS (INCHES)

**Notes:**

1. The HFCT-5903 is not recommended due to the potential degradation of EMI performance in a complete system.
2. This page describes the maximum package outline, mounting studs, pins and their relationships to each other.
3. Toleranced to accommodate round or rectangular leads.
4. The 10 I/O pins, 2 solder posts and 4 package grounding tabs are to be treated as a single pattern. (see Figure 6 PCB layout)
5. The MT-RJ has a 750  $\mu\text{m}$  fiber spacing.
6. The MT-RJ alignment pins are in the module.
7. See MT-RJ Transceiver Pin Out Diagram for details.

**Figure 5. HFCT-5905 Package Outline Drawing**

### Board Layout - Decoupling Circuit and Ground Planes

It is important to take care in the layout of your circuit board to achieve optimum performance from these transceivers. Figure 3 provides a good example of a schematic for a power supply decoupling circuit that works well with these parts. It is further recommended that a continuous ground plane be provided in the circuit board directly under the transceiver to provide a low inductance ground for signal return current. This recommendation is in keeping with good high frequency board layout practices.

### Board Layout - Hole Pattern

The Hewlett-Packard transceiver complies with the circuit board "Common Transceiver Footprint" hole pattern defined in the original multisource announcement which defined the 2 x 5 package style. This drawing is reproduced in Figure 6 with the addition of ANSI Y14.5M compliant dimensioning to be used as a guide in the mechanical layout of your circuit board. Figure 7 shows the front panel dimensions associated with such a layout.

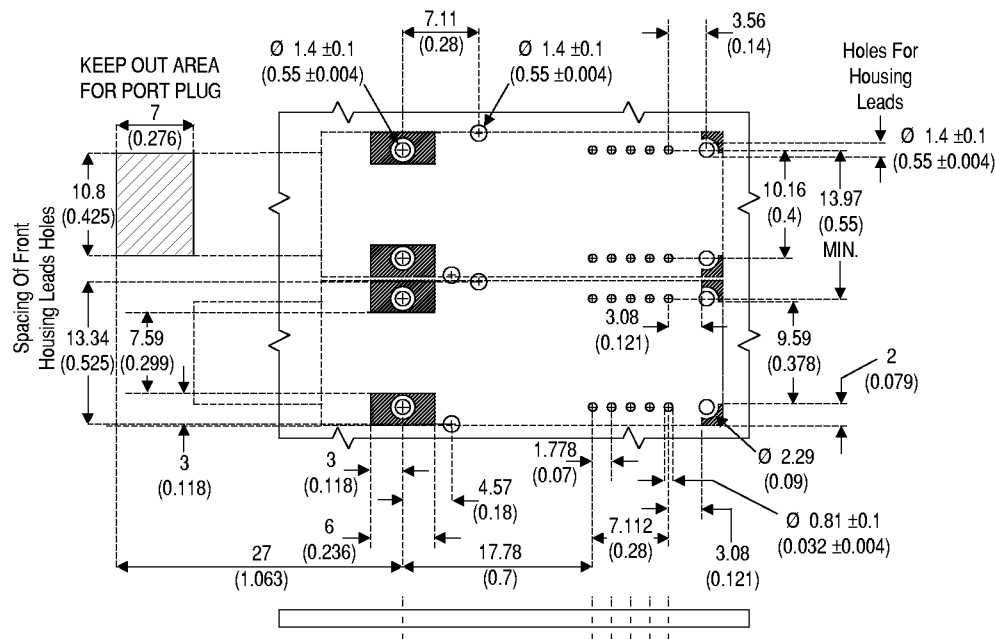

DIMENSIONS IN MILLIMETERS (INCHES)

#### Notes:

1. This figure describes the recommended circuit board layout for the MT-RJ Transceiver placed at .550 spacing.
2. The hatched areas are keep-out areas reserved for housing standoffs. No metal traces or ground connection in keep-out areas.
3. 2 x 5 Transceiver module requires 16 PCB holes (10 I/O pins, 2 solder posts and 4 package grounding tabs). Package grounding tabs should be connected to signal ground.
4. The Solder Posts should be soldered to chassis ground for mechanical integrity and to ensure footprint compatibility with other SFF transceivers.

Figure 6. Recommended Board Layout Hole Pattern

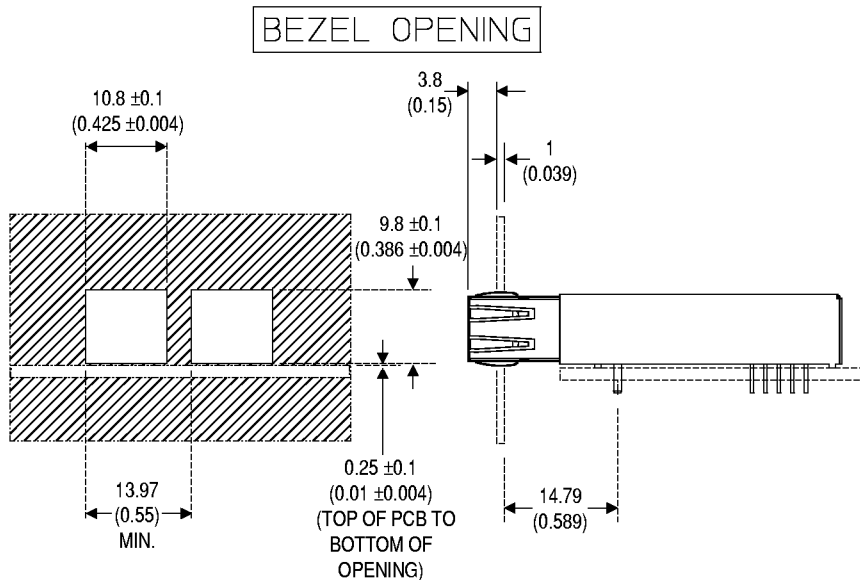

DIMENSIONS IN MILLIMETERS (INCHES)

**Note:** Nose shield should be connected to chassis ground.

**Figure 7. Recommended Panel Mounting**

## Design Support Materials

Further technical details and supporting information regarding small form factor transceivers are contained in an application note aimed at providing useful information to the fiber-optic system designer. This document describes PC board layout techniques, power supply filtering, EMI considerations and interfacing options. HP has created a number of reference designs with major PHY IC vendors in order to establish full functionality and interoperability. Such design information and results can be made available to the designer as a technical aid. Please contact your Hewlett-Packard representative for further information if required.

## Ordering Information

### HFCT-5905E

Model Name:

HFCT-5905E - Preferred option with nose shield fitted

HFCT-5905 - Non-preferred option without nose shield

**Class 1 Laser Product:** This product conforms to the applicable requirements of 21 CFR 1040 at the date of manufacture

Date of Manufacture: \_\_\_\_\_

Hewlett Packard Ltd., Depot Road, Singapore

[www.hp.com/go/fiber](http://www.hp.com/go/fiber)

For technical assistance or the location of your nearest Hewlett-Packard sales office, distributor or representative call:

**Americas/Canada:** 1-800-235-0312 or 408-654-8675

**Far East/Australasia:** Call your local HP sales office.

**Japan:** (81 3) 3335-8152

**Europe:** Call your local HP sales office.

Data subject to change.

Copyright © 1999 Hewlett-Packard Co.

5968-5829E (5/99)

## Handling Precautions

1. The HFCT-5905E can be damaged by current surges or overvoltage. Power supply transient precautions should be taken.
2. Normal handling precautions for electrostatic sensitive devices should be taken.