



3.2 mm x 2.5 mm Ceramic Low Noise SMD VCXO  
LVCMOS/LVPECL/LVDS



I643 Series

**Product Features**

Small Surface Mount Package  
Fast Sample Delivery  
Fast Sample Delivery  
Pb Free/ RoHS Compliant  
Leadfree Processing

**Applications**

xDSL  
Broadcast Video  
Wireless Base Stations  
Sonet /SDH  
WiMAX/WLAN  
Server and Storage

Ethernet/LAN/WAN  
Optical modules  
Clock and data recovery  
FPGA/ASIC  
Backplanes  
GPON

<b>Frequency</b> LVCMOS LVPECL LVDS	10.000MHz to 250.000MHz 10.000MHz to 1500.000MHz 10.000MHz to 1500.000MHz
<b>Output Level</b> LVCMOS LVPECL LVDS	Logic "0" = 10% of Vcc max., Logic "1" = 90% of Vcc min. Logic "0" = Vcc-1.62V max., Logic "1" = 1.02 V min VOD = (Diff. Output) 350mV Typ.
<b>Duty Cycle</b> LVCMOS LVPECL LVDS	50% ±5% @ 50% of Vcc 50% ±5% @ 50%* 50% ±5% @ 50%*
<b>Rise / Fall Time</b> LVCMOS LVPECL LVDS	2.0 ns max. (10% to 90%)* 0.8 ns max. (20% to 80%)* 0.8 ns max. (20% to 80%)*
<b>Output Load</b> LVCMOS LVPECL LVDS	15pF 50 Ω to Vcc - 2.0 VDC RL=100 Ω/CL= 5pF
<b>Frequency Stability</b>	See Table Below
<b>Supply Voltage (Vcc)</b>	+3.30 VDC ± 5%, +2.50 VDC ± 5%
<b>Aging</b>	±3.0 ppm max per year
<b>Current</b>	HCMOS = 45 mA max LVPECL = 90 mA max LVDS = 35 mA max
<b>Linearity</b>	10% max.
<b>Pullability</b>	See Table Below
<b>Control Voltage</b>	1.65 VDC ± 1.65 VDC @ 3.3V 1.25 VDC ± 1.25 VDC @ 2.5V
<b>Input Impedance</b>	50K Ω min.
<b>Phase Jitter(RMS) At 12kHz to 20MHz</b>	0.5 ps typical (12kHz to 20MHz)
<b>Operating Temp. Range</b>	See Table Below
<b>Storage Temp. Range</b>	-40° C to +85° C

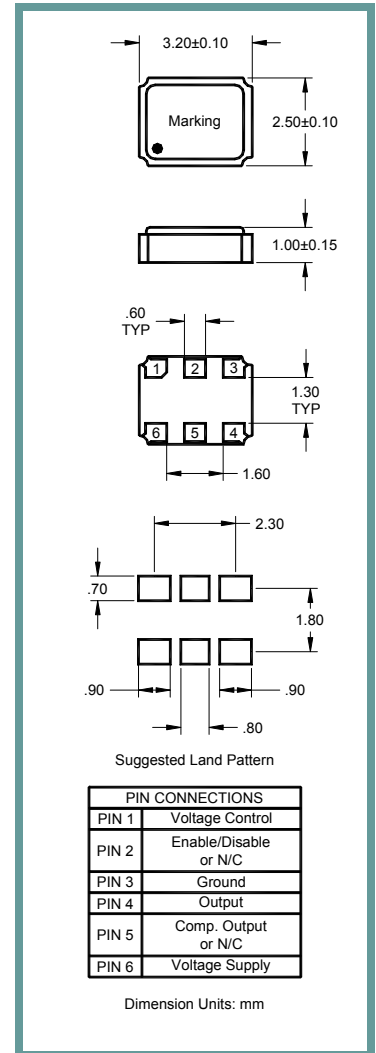

Part Number Guide		Sample Part Number: I643-31AB9H2-155.520						
Package	Input Voltage	Operating Temperature	Stability (in ppm)	Pullability	Output	Enable / Disable (Pin 2)	Complimentary Ouput (Pin 5) **	Frequency
I643	3 = 3.3V	1 = 0° C to +70° C	F = ±20	B = ± 50	3 = LVCMOS	H = Enable	1 = N.C.	-155.520 MHz
	6 = 2.5V	2 = -40° C to +85° C	A = ±25	C = ±100	8 = LVDS	O = N/C	2 = Output	
		3 = -20° C to +70° C	B = ±50		9 = LVPECL			

NOTE: A 0.01 µF bypass capacitor is recommended between V<sub>DD</sub> (pin 6) and GND (pin 3) to minimize power supply noise. \* Measured as percent of waveform. \*\* Available on LVDS and LVPECL ouput only.



3.2 mm x 2.5 mm Ceramic Low Noise SMD VCXO  
LVCMOS/LVPECL/LVDS



I643 Series

### SSB Phase Noise (typ.)

Offset	77.76 MHz	155.52 MHz	622.08 MHz
10Hz	-75 dBc/Hz	-62 dBc/Hz	-47 dBc/Hz
100Hz	-105 dBc/Hz	-101 dBc/Hz	-79 dBc/Hz
1kHz	-117 dBc/Hz	-112 dBc/Hz	-100 dBc/Hz
10kHz	-123 dBc/Hz	-115 dBc/Hz	-104 dBc/Hz
100kHz	-125 dBc/Hz	-118 dBc/Hz	-106 dBc/Hz

### Typical Application:

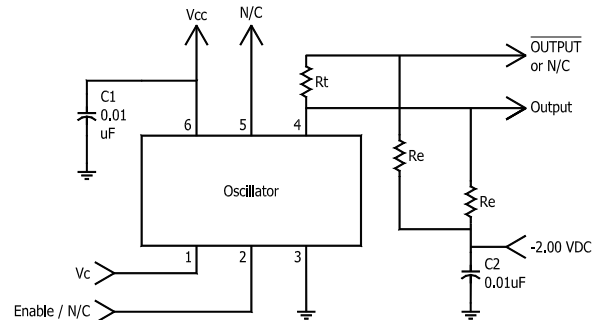
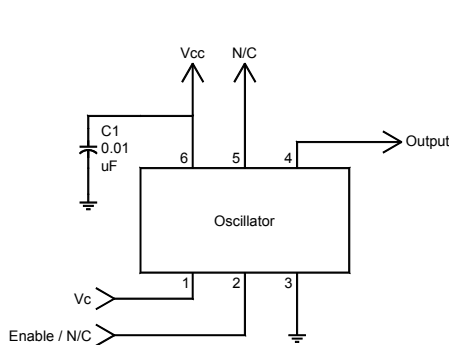

- Notes;  
 1. LVPECL Load = Use Re and -2.0 VDC Source.  
 2. LVDS Load = Omit Re and use Rt.

### Pb Free Solder Reflow Profile:

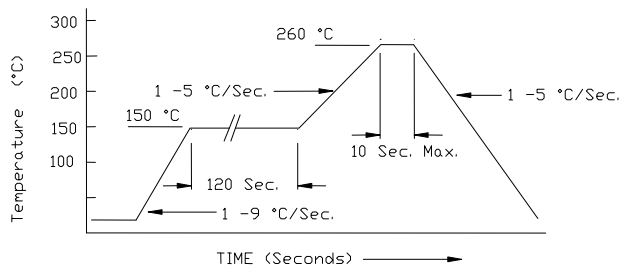

\*Units are backward compatible with 240C reflow processes

### Package Information:

MSL = N.A. (package does not contain plastic, storage life is unlimited under normal room conditions).  
 Termination = e4 (Au over Ni over W base metallization).

**QUALITY SYSTEM  
 CERTIFIED  
 = ISO 9001 =**

ILSI America Phone 775-851-8880 • Fax 775-851-8882 • email: e-mail@ilsiamerica.com •  
[www.ilsiamerica.com](http://www.ilsiamerica.com)

Specifications subject to change without notice

Rev: 03/10/15\_A

Page 2 of 3



3.2 mm x 2.5 mm Ceramic Low Noise SMD VCXO  
LVCMOS/LVPECL/LVDS



I643 Series

## Tape and Reel Information:

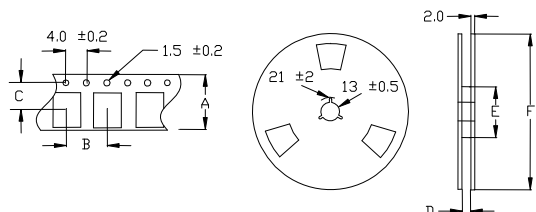

Quantity per Reel	1000
A	16 +/- .3
B	8 +/- .2
C	7.5 +/- .2
D	17.5 +/- 1
E	50 / 60 / 80
F	180 / 250

## Environmental Specifications

Thermal Shock	MIL-STD-883, Method 1011, Condition A
Moisture Resistance	MIL-STD-883, Method 1004
Mechanical Shock	MIL-STD-883, Method 2002, Condition B
Mechanical Vibration	MIL-STD-883, Method 2007, Condition A
Resistance to Soldering Heat	J-STD-020C, Table 5-2 Pb-free devices (except 2 cycles max)
Hazardous Substance	Pb-Free / RoHS / Green Compliant
Solderability	JESD22-B102-D Method 2 (Preconditioning E)
Terminal Strength	MIL-STD-883, Method 2004, Test Condition D
Gross Leak	MIL-STD-883, Method 1014, Condition C
Fine Leak	MIL-STD-883, Method 1014, Condition A2, R1=2x10 <sup>-8</sup> atm cc/s
Solvent Resistance	MIL-STD-202, Method 215

## Marking

Line 1: ILSI and Date Code (YWW)

Line 2: Frequency

### PROPRIETARY AND CONFIDENTIAL

THIS DOCUMENT CONTAINS PROPRIETARY INFORMATION, AND SUCH INFORMATION MAY NOT BE DISCLOSED TO OTHERS FOR ANY PURPOSE NOR USED FOR MANUFACTURING PURPOSES WITHOUT WRITTEN PERMISSION FROM ILSI America.