

AKU342

Bottom port, Analog Silicon MEMS Microphone

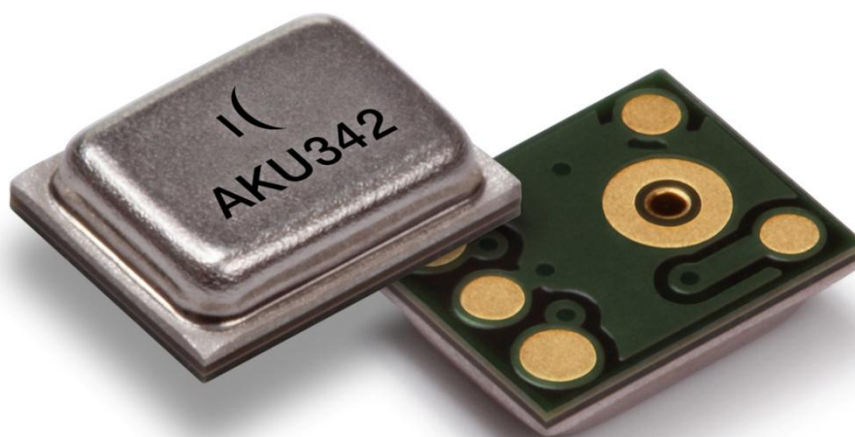

Data Sheet

Part number(s)	AKU342
Package type	6-pin LGA bottom port
Data sheet revision	1.04
Release date	10 October 2014
Document number	DS28-1.04 AKU342 Data Sheet
Notes	Specifications are subject to change without notice. Product photos and pictures are for illustration purposes only and may differ from the real product's appearance.

AKU342

Analog, HD Voice Silicon MEMS Microphone

General Description

AKU342 is an HD Voice quality, bottom port, analog output silicon MEMS IC microphone. It is an integrated circuit (IC) consisting of a MEMS acoustic sensor, a pre-amplifier, charge pump, and supporting circuitry in an industry standard package footprint of 2.95mm x 3.76mm x 1.00mm.

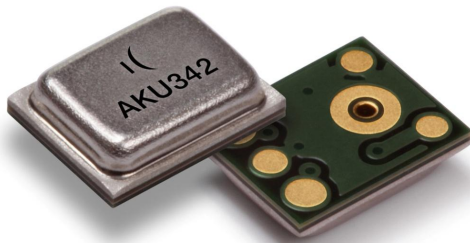

Designed specifically to meet the demanding requirements of mobile handset OEMs, AKU342 offers excellent acoustic performance with 63dB signal-to-noise ratio (SNR) and tight sensitivity matching of just +/-2dB between microphones. It also offers a flat wideband frequency response with less than 5dB variations from 50 Hz to 14 kHz, delivering uniform audio capture across a broad audio spectrum. The AKU342 metal lid package is immune to RF and Electromagnetic (EM) interferences, allowing for easy integration into wireless devices.

Key Features

- Bottom port, Analog output
- Omni-directional audio sensor
- Excellent acoustic performance: 63dB SNR
- Tight sensitivity tolerance: -38dB +/- 2 dB
- Matched microphones in frequency and phase response for array applications
- Flat frequency response for super-wideband audio
- Package immune to RF/EM interference
- Lead-free, surface-mountable and RoHS2 compliant
- Halogen-free in accordance with IEC61249-2-21
- Thin profile, SMT packaging
- Industry-standard package of: 2.95 x 3.76 x 1.00 mm³

Typical Applications

- Smartphones and mobile phones which require high quality acoustic performance in a small form factor microphone
- Digital still/video cameras
- IC / digital voice recorders
- Portable media players
- Gaming consoles / controllers
- Voice activated entertainments systems and remote controllers
- Smart-home sensor hubs / clusters, and IoTS acoustic sensor nodes
- Microphone arrays – multi-mic applications and noise cancellation algorithms which benefit from microphones with tightly matched sensitivity and phase
- Products designed to capture super-wideband audio that require a microphone with less than 5dB variation in frequency response from 50Hz-14kHz
- Other small, thin consumer electronic devices using more than one microphone

	AKU342 Analog Silicon MEMS Microphone	Data Sheet
---	---	------------

Index of Contents

1. ABSOLUTE MAXIMUM RATINGS.....	4
2. STANDARD OPERATING CONDITIONS.....	4
3. ELECTRICAL AND ACOUSTIC SPECIFICATIONS	4
4. DEVICE CHARACTERISTICS	5
4.1 Typical Frequency Response	
4.2 I_{DD} vs. V_{DD}	
4.3 Sensitivity vs. V_{DD}	
4.4 Total Harmonic Distortion	
4.5 Sensitivity vs. Temperature	
4.6 PSRR vs. Frequency	
5. MECHANICAL SPECIFICATIONS.....	6
6. PIN-OUT AND CONNECTION DIAGRAMS.....	7
6.1 Pin Out	
6.2 Schematic	
7. MANUFACTURING NOTES.....	8-10
7.1 Solder Reflow	
7.2 Part Handling	
7.3 PCB Land Pattern & Stencil Pattern	
8. RELIABILITY SPECIFICATIONS.....	11
9. PART MARKING INFORMATION.....	11
10. PACKAGING INFORMATION.....	12
11. ORDERING INFORMATION	13
12. DOCUMENT REVISIONS.....	13

	AKU342 Analog Silicon MEMS Microphone	Data Sheet
---	---	------------

1. ABSOLUTE MAXIMUM RATINGS

Supply Voltage, V_{DD} to GND	5.5V
ESD Tolerance	
Human Body Model	2000V
Machine Model	200V
Storage Temperature Range	-40°C to 105°C

2. STANDARD OPERATING CONDITIONS

Operating Temperature Range	-40°C to 85°C
Supply Voltage (V_{DD})	1.6V to 3.6V

3. ELECTRICAL AND ACOUSTIC SPECIFICATIONS

Unless otherwise noted, test conditions are:
 $V_{DD} = 2.0V$ $T_a = 25^\circ C$ $RH = 50\%$

Parameter	Test Conditions	Min.	Typ.	Max.	Unit
Directivity		Omni-directional			
Signal to Noise Ratio (SNR)	$f_{in} = 1 \text{ kHz}$, A-weighted, 20Hz-10kHz		63		dB
Low Frequency Corner	-3dB from 1kHz sensitivity value		60		Hz
Upper Frequency Corner	+3dB from 1kHz sensitivity value		10		kHz
Sensitivity ¹	1kHz, 94dB SPL	-40	-38	-36	dBV/Pa
Total Harmonic Distortion (THD) ¹	@ 94dB SPL, $f_{in} = 1 \text{ kHz}$			1	%
	@ 114dB SPL, $f_{in} = 1 \text{ kHz}$			5	
Power Supply Rejection Ratio (PSRR)	100mVpp, $f = 217\text{Hz}$	60			dB
Current Consumption ¹	No load			300	μA
Output Impedance				200	Ω
Sensitivity loss across voltage	Change in sensitivity over 3.6V to 1.6V		0		dB
Part-to-part phase matching	From nominal @ 1kHz			± 10	$^\circ$
Polarity	Increasing sound pressure	Increasing output voltage			

Note 1: Parameter 100% tested

4. DEVICE CHARACTERISTICS

4.1 Frequency Response

(Measured frequency response normalized to 1kHz)

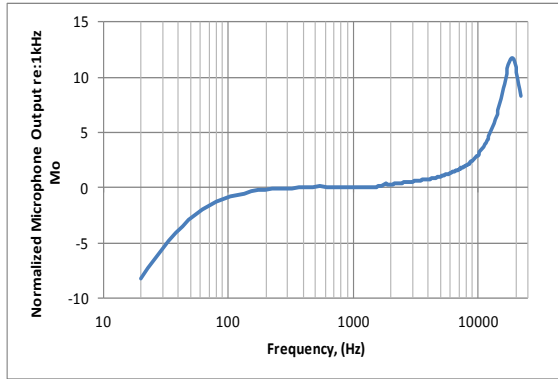

4.2 I_{DD} vs. V_{DD}

(Measured current consumption relative to supply voltage)

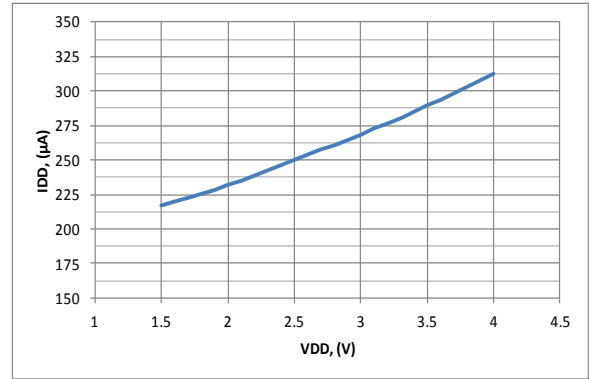

4.3 Sensitivity vs. V_{DD}

(Measured sensitivity changes relative to supply voltage)

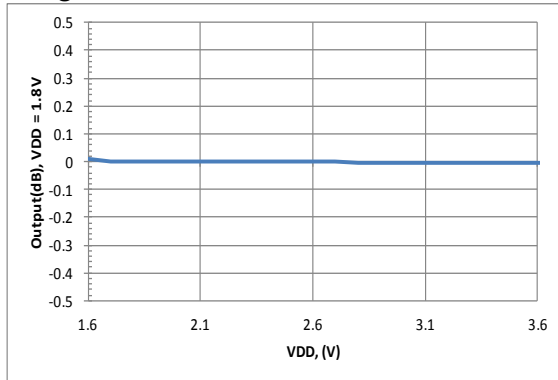

4.4 Total Harmonic Distortion

(Measured THD relative to speaker output pressure level)

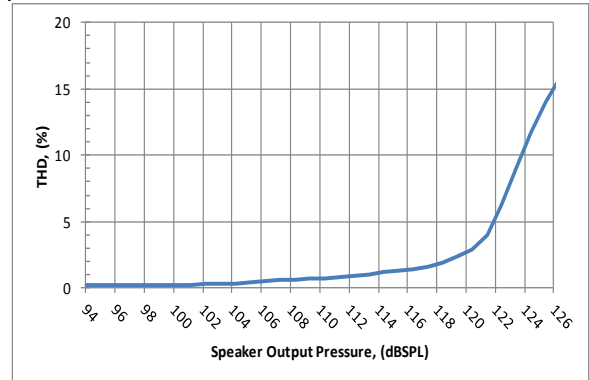

4.5 Sensitivity vs. Temperature

(Typical sensitivity changes relative to temperature)

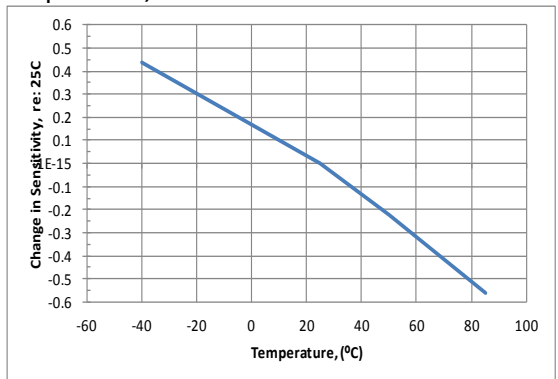

4.6 PSRR vs. Frequency

(Typical PSRR relative to frequency)

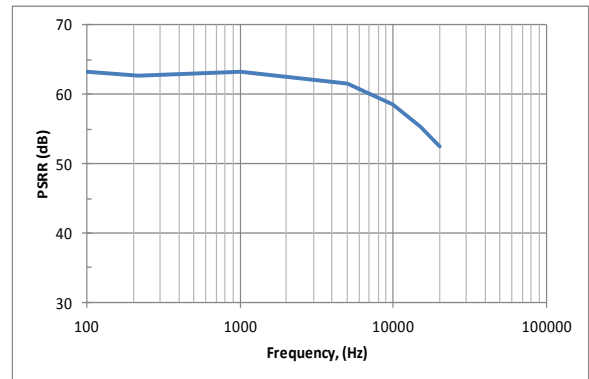

5. MECHANICAL SPECIFICATIONS

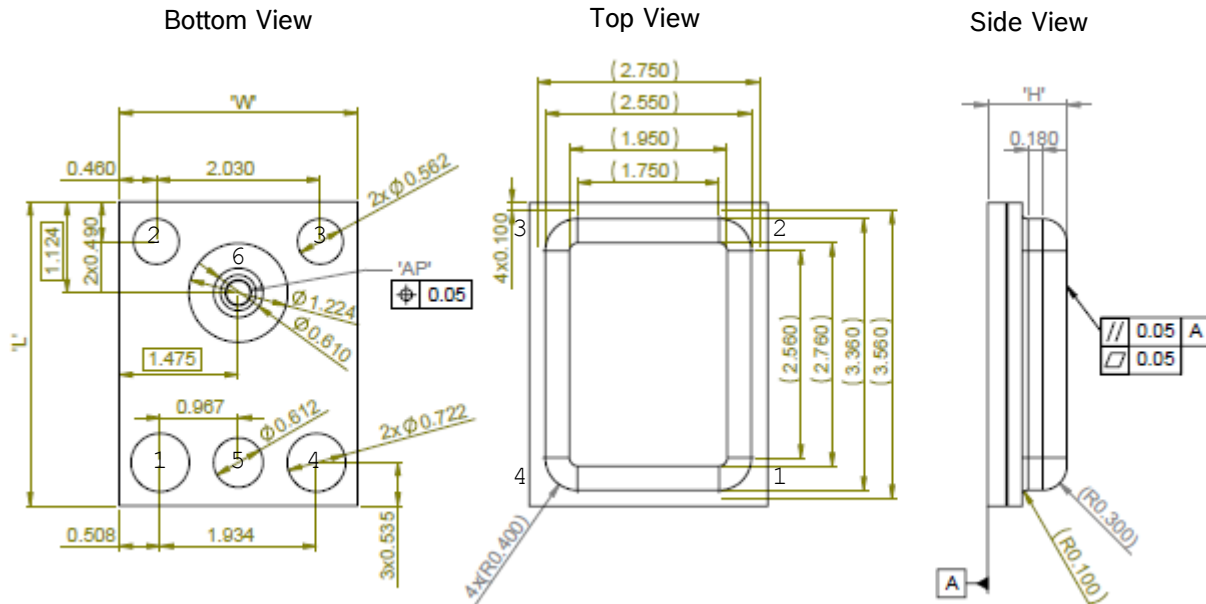

Item	Dimension	Tolerance	Units
Length (L)	3.76	± 0.10	mm
Width (W)	2.95	± 0.10	mm
Height (H)	1.00	± 0.10	mm
Acoustic Port (AP)	0.30	± 0.03	mm
Planarity	Top/Bottom	± 0.05	mm
All dimensions in mm Tolerance ± 0.05 mm unless otherwise specified			

6. PIN-OUT AND CONNECTION DIAGRAMS

6.1 Pin-Out (As viewed from bottom of package)

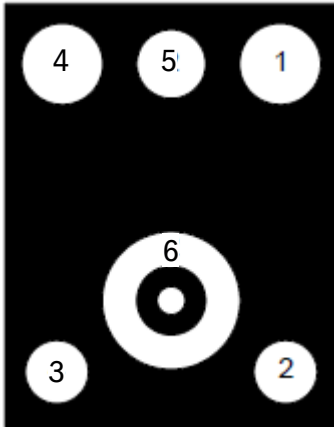

Pin	Name	Function
1	OUT	Analog output voltage
2	GND	Ground
3	NC/GND ¹	No Connect or Ground
4	V _{DD}	Power supply voltage for microphone
5, 6	GND	Ground

Note 1: Pin 2 must be Ground. Pin 3 can be left as No Connect or tied to Ground.

6.2 Typical Application Schematic

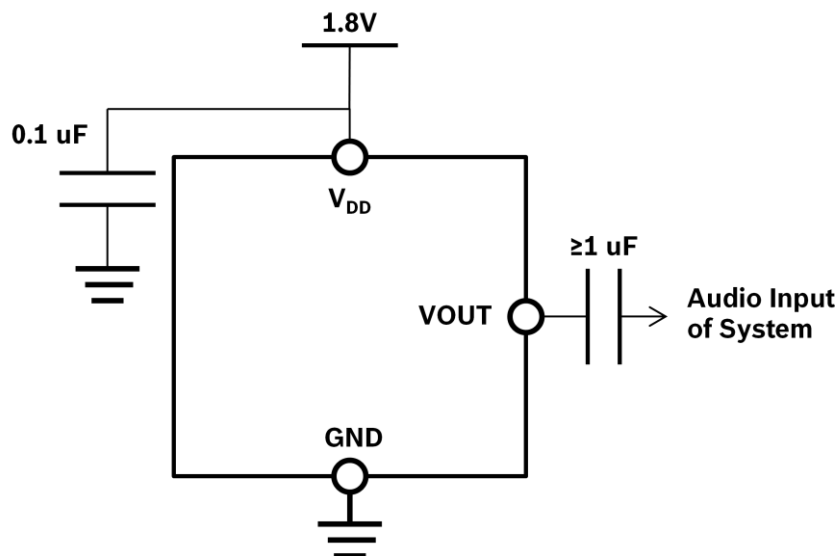

7. MANUFACTURING NOTES

7.1 Solder Reflow

Typical solder reflow profile

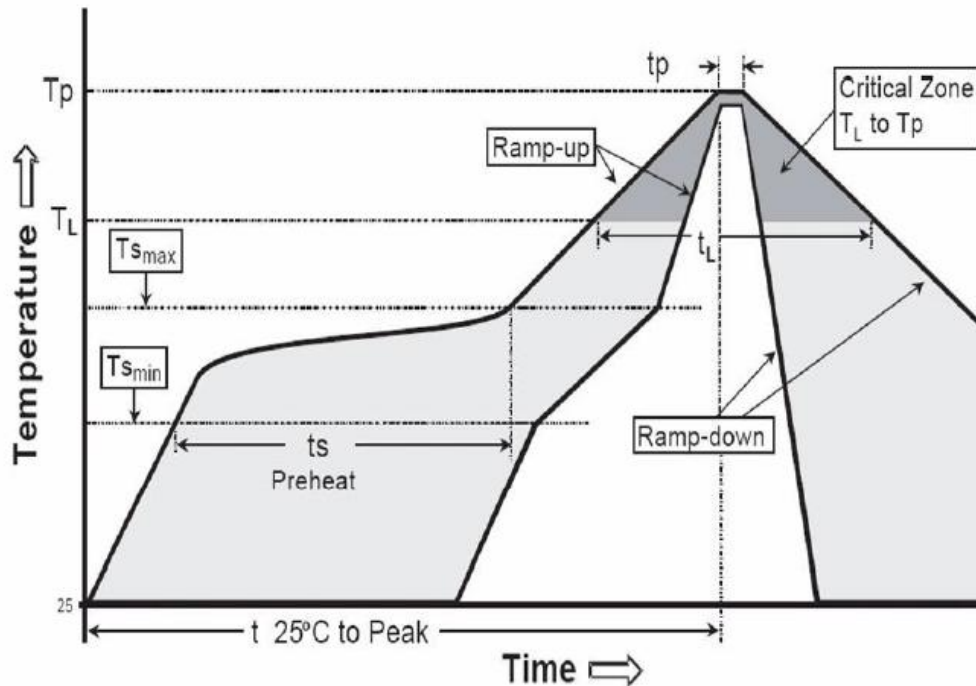

IPC-0206-5-1

Average ramp-up rate	max. 3°C/s
Time t_s between $T_{s_{min}}$ (150°C) and $T_{s_{max}}$ (200°C)	60s – 120s
Time t_L above liquidous temperature T_L (217°C)	60s – 90s
Peak temperature T_P	max. 260°C
Time t_p at T_P	max. 20s
Average ramp-down rate	max. 6°C/s

Note: It is recommended to fine-tune the reflow process to optimize for variations in materials, environment, handling, PCB board size and thickness, etc.

Please refer to AN60-Handling, Soldering, and Mounting Instructions for more detailed information and precautions.

	AKU342 Analog Silicon MEMS Microphone	Data Sheet
---	---	------------

7.2. Microphone Handling

Although the microphone may not appear damaged immediately due to inappropriate handling, there can be long term effects that affect the lifetime of the component.

Rule of thumb: The microphone is an artificial ear so treat it like your own ear.

- Do not blow air into the acoustic port of the microphone for any reason. Do not subject it to pressurized air
 - e.g. when cleaning the board or other components on the same board
- Do not apply vacuum to the acoustic port of the microphone
- Do not insert liquids
 - If populated circuit boards are washed, the microphone must be protected
- Do not insert dust
 - The production facilities must be clean
 - e.g. if PCB routing/sawing is done close to the microphone after SMT assembly and reflow
- Do not insert any objects
 - If assembly or rework is done manually, care must be taken that the tools cannot enter the microphone sound port
 - It is best to choose tool size so that it does not fit through the sound port of the microphone
- Do not cover the acoustic port with tape when heating during assembly or reflow
- Do not apply extreme mechanical stresses on the microphone, including mechanical shocks above 10kG or compression of the microphone package.
- After a bottom port microphone has been assembled on a circuit board, protect the sound port (now on the other side of the board) from dust, liquids, and other foreign materials as well as any tools and pressurized air.

ESD Handling Procedures



Follow CMOS handling procedures with Akustica MEMS microphones. Handle the microphone with proper workplace grounding to include wrist straps and ionized airflow over open trays and reels of microphones. Do not hot-swap/hot-plug during testing. Device pins have ESD ratings of 2kV/200V for HBM/MM respectively.

	AKU342 Analog Silicon MEMS Microphone	Data Sheet
---	---	------------

7.3 PCB Land Pattern and Stencil Pattern

PCB Land Pattern Layout

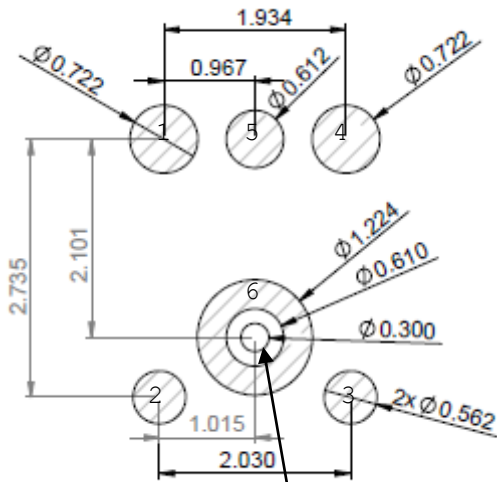

Acoustic port (PCB must be drilled here)

Suggested Solder Paste Stencil Pattern Layout

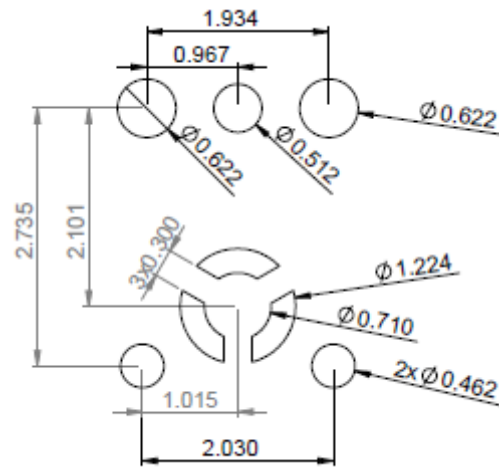

Note: Stencil printer settings will likely require minor optimizations when transferring this stencil pattern to a high volume production printer.

Please refer to AN60-Handling, Soldering, and Mounting Instructions for more detailed information and precautions.

	AKU342 Analog Silicon MEMS Microphone	Data Sheet
---	---	------------

8. RELIABILITY SPECIFICATIONS

The microphone sensitivity after stress must deviate by no more than 3dB from the initial value.

	Test	Test Condition
1	Cold Temp Operation	Temperature = -40°C, 1000 hours (with bias)
2	Hot Temp Operation	Temperature = 105°C, 1000 hours (with bias)
3	Humidity Operation	Temperature = 85°C, RH = 85%, 1000 hours (with bias)
4	Cold Temp Storage	Temperature = -40°C, 1000 hours (without bias)
5	Hot Temp Storage	Temperature = 105°C, 1000 hours (without bias)
6	Humidity Storage	Temperature = 85°C, RH = 85%, 1000 hours (without bias)
7	Thermal Cycle	100 Cycles, -40°C to +125°C, 15min soaks, <30sec ramps
8	Vibration	Sinusoidal Vibration, 20Hz-2000Hz, 4min sweeps, 16min along each of 3 axis, amplitude 3 limits of 20G and 0.06"
9	Mechanical Shock	10,000G shocks, 5 impacts along each of 6 axes
10	Drop Test	Using 150gm aluminum fixture, 3 drops along each of 6 axes (total 18 drops) from 1.5m height onto concrete drop surface.
11	ESD (HBM)	+/-2000V, 1 discharge for each polarity, 11 pin combinations, 22 total discharges per microphone
12	ESD (MM)	+/- 200V, 1 discharge for each polarity, 11 pin combinations, 22 total discharges per microphone
13	ESD	+/- 8kV, contact discharge to lid with DUT grounded
14	Moisture Sensitivity Level	24 hour bake at 125°C, followed by 168 hours at 85°C, 85%RH, followed by 3 passes solder reflow (MSL Level 1)

9. PART MARKING INFORMATION

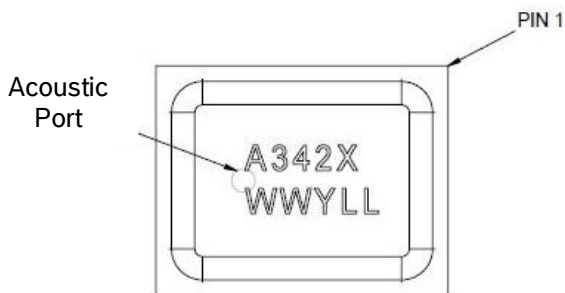

Line 1: A342X (A = Akustica, Part Code = 342, X = Assembly Facility)
 Line 2: WWYLL (WW = Work Week, Y = Year, LL = Lot Number Processed During Work Week)

10. PACKAGING INFORMATION

10.1 Tape Specification

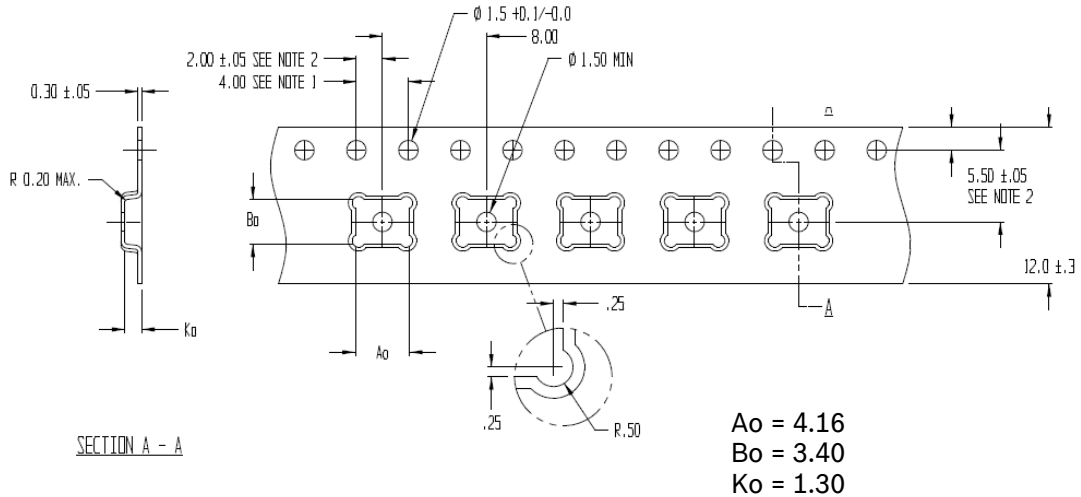

Notes:

1. 10 sprocket hole pitch cumulative tolerance ± 0.2
2. Camber in compliance with EIA-481
3. Pocket position relative to sprocket hole measured as true position of pocket, not pocket hole
4. A_o and B_o are calculated on a plane at a distance of "R" above the bottom of the pocket.

10.2 Component Orientation

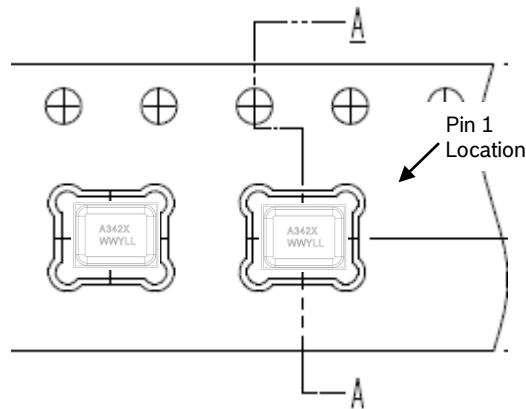

	AKU342 Analog Silicon MEMS Microphone	Data Sheet
---	---	------------

11. ORDERING INFORMATION

Part Number	Order Number ¹	Part Code	Package	Shipping Method	Standard Quantity
AKU342	02730A0008 02730A3003	A342	6-Pad LGA	13" Reel	5,700

Note 1: Please contact Akustica to determine the appropriate order number when placing an order.

12. DOCUMENT REVISIONS

Rev. No	Description of modification/changes	Date
1.0	Updated for final. Released 1.0.	13-Jun-13
1.01	Updated order number to 3003 from 0003.	23-Aug-13
1.02	Updated order numbers for new order code system. RoHS compliance to RoHS2. Added pin identification numbers	15-Oct-13
1.03	Edited cover page. Reformatted the part description / general description page (pg. 2). Updated footnote regarding AN60 in section 7.	10-Feb-14
1.04	Updated headers and PCB layout AP	10-Oct-14

Akustica, Inc.
 2835 E Carson St. Suite 301
 Pittsburgh, PA / USA 15203
 (412) 390-1730

sales@akustica.com
www.akustica.com/contact.asp

Modifications reserved | Printed in USA
 Specifications subject to change without notice