

# Alternator Voltage Regulator Darlington Driver

## Description

The CS-3341/3351/386/387 integral alternator regulator integrated circuit provides the voltage regulation for automotive, 3-phase alternators.

It drives an external power Darlington for control of the alternator field current. In the event of a charge fault, a lamp output pin is

provided to drive an external darlington transistor capable of switching on a fault indicator lamp. An overvoltage or no STATOR signal condition activates the lamp output.

The CS-3341 and CS-3351 are available in SO14 packages. The CS-386 and CS-387 are available as Flip Chips.

## Features

- Drives NPN Darlington
- Short Circuit Protection
- 80V Load Dump
- Temperature Compensated Regulation Voltage
- Shorted Field Protection Duty Cycle, Self Clearing

## Absolute Maximum Ratings

Storage .....	-55°C to +165°C
Operating	
CS-3341/51 .....	-40°C to +125°C
CS-386/387 .....	-40°C to +150°C
Junction .....	150°C
Continuous Supply .....	27V
ICC Load Dump .....	400 mA
Lead Temperature Soldering	
Reflow (SMD styles only).....	60 sec. max above 183°C, 230°C peak

## Block Diagram

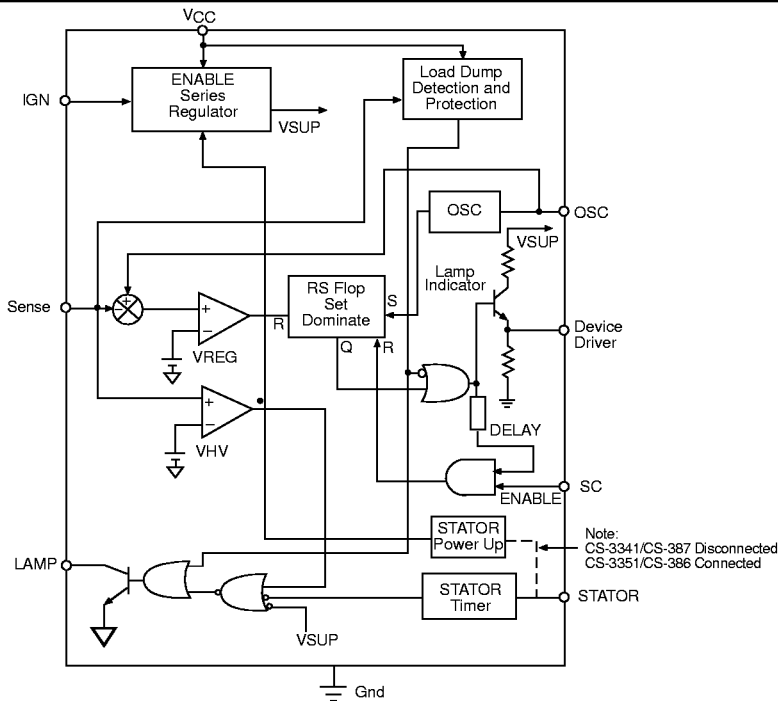

## Package Options

CS-3341/51

14 Lead SO

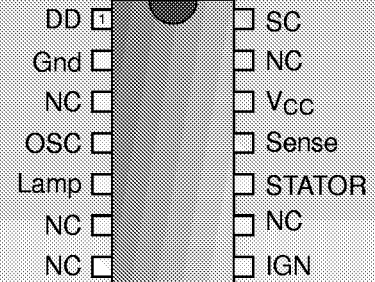

CS-386/387

Flip Chip

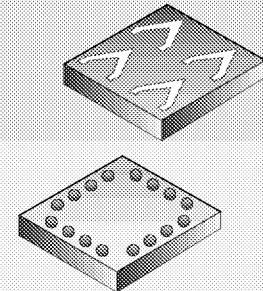

Electrical Characteristics:  $-40^{\circ}\text{C} < T_j < 150^{\circ}\text{C}$ ,  $9\text{V} \leq V_{\text{CC}} \leq 17\text{V}$  unless otherwise specified

PARAMETER	TEST CONDITIONS	MIN	TYP	MAX	UNIT
<b>■ Supply</b>					
Supply Current Enabled		-	12	25	mA
Supply Current Disabled		-		50	$\mu\text{A}$
<b>■ Driver Stage</b>					
Device Driver		-		-	-
Output High Current	$V_{\text{DD}} = 1.2\text{V}$	-10	-6	-4	mA
Output Low Voltage	$I_{\text{OL}} = 25\mu\text{A}$	-		0.35	V
Minimum ON Time		200			$\mu\text{s}$
Minimum Duty Cycle		-	6	10	%
Field Switch Turn On Rise Time		30		90	$\mu\text{s}$
Fall Time		30		90	$\mu\text{s}$
<b>■ Stator</b>					
Input High Voltage		10			V
Input Low Voltage		-		6	V
Stator Time Out	High to Low	6	100	600	ms
Stator Power-Up Input High	CS-3351/386 only	10		-	V
Stator Power-Up Input Low	CS-3351/386 only	-		6	V
<b>■ Lamp</b>					
Output High Current	$V_{\text{LAMP}} @ 3\text{V}$	-		50	$\mu\text{A}$
Output Low Voltage	$I_{\text{LAMP}} @ 30\text{mA}$	-		0.35	V
Lamp Drive-Dynamic Rise Time	$R_L = 600, C_L = 100\text{pf}$	-		1	$\mu\text{s}$
Fall Time	$R_L = 600, C_L = 100\text{pf}$	-		1	$\mu\text{s}$
<b>■ Ignition</b>					
Input High Voltage	$I_{\text{CC}} > 1\text{mA}$	1.8		-	V
Input Low Voltage	$I_{\text{CC}} < 100\mu\text{A}$	-		0.5	V
<b>■ Oscillator</b>					
Oscillator Frequency	$C_{\text{OSC}} = 0.22\mu\text{F}$	65		325	Hz
Rise Time/Fall Time	$C_{\text{OSC}} = 0.22\mu\text{F}$		17	-	-
Oscillator High Threshold	$C_{\text{OSC}} = 0.22\mu\text{F}$	-		6	V
<b>■ Battery Sense</b>					
Input Current		-10		+10	$\mu\text{A}$
Regulation Voltage	@ $25^{\circ}\text{C}$ , $R_1 = 100\text{k}\Omega$ , $R_2 = 50\text{k}\Omega$	13.5		16.0	V
Proportional Control		0.050		0.400	V
High Voltage Threshold Ratio	$\frac{V_{\text{High Voltage @ Lamp On}}}{V_{\text{Regulation @ 50% Duty Cycle}}}$	1.083		1.190	
High Voltage Hysteresis		0.020		0.600	V

## Package Pin Description

CS-3341/3351/386/387

PACKAGE PIN #		PIN SYMBOL	FUNCTION
<b>14L SO</b>	<b>Flip Chip</b>		
1	1	Driver	Output driver for external power switch-Darlington
2	2	Gnd	Ground
3, 6, 7, 9, 13	3	NC	No connection
4	4	OSC	Timing capacitor for oscillator
5	5	Lamp	Base driver for lamp driver indicates no stator signal or over-voltage condition
8	6	IGN	Switched ignition power up
10	7	Stator	Stator signal input for stator timer (CS-3351 also power up)
11	8	Sense	Battery sense voltage regulator comparator input and protection
12	9	V <sub>CC</sub>	Supply for IC
14	10	SC	Short circuit sensing

## Application Information

The CS-3341 and CS-3351 IC's are designed for use in an alternator charging system. The circuit is also available in flip-chip form as the CS-387 and CS-386.

In a standard alternator design (Figure 1), the rotor carries the field winding. An alternator rotor usually has several N and S poles. The magnetic field for the rotor is produced by forcing current through a field or rotor winding. The Stator windings are formed into a number of coils spaced around a cylindrical core. The number of coils equals the number of pairs of N and S poles on the rotor. The alternating current in the Stator windings is rectified by the diodes and applied to the regulator. By controlling the amount of field current, the magnetic field strength is controlled and hence the output voltage of the alternator.

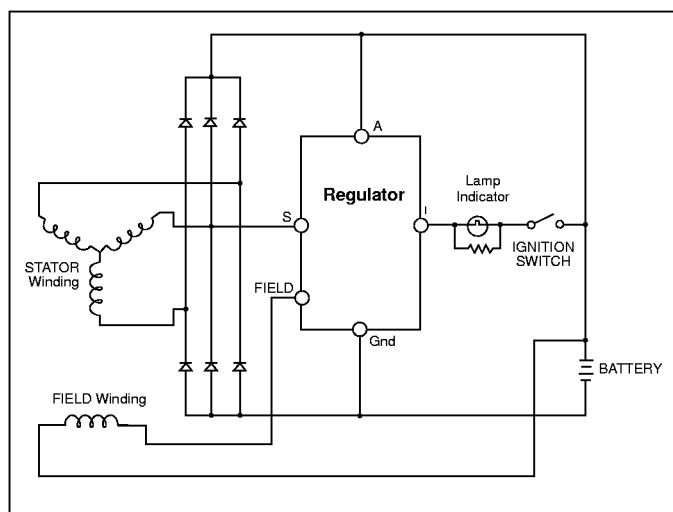

Figure 1. IAR System Block Diagram

Referring to Figure 2, a typical application diagram, the oscillator frequency is set by an external capacitor connected between OSC and ground. The sawtooth waveform ramps between 1V and 3V and provides the timing for the system. For the circuit shown the oscillator frequency is approximately 140Hz. The alternator voltage is sensed at Terminal A via the resistor divider network R1/R2 on the Sense pin of the IC. The voltage at the sense pin determines the duty cycle for the regulator. The voltage is adjusted by potentiometer R2. A relatively low voltage on the sense pin causes a long duty cycle that increases the Field current. A high voltage results in a short duty cycle.

The ignition Terminal (I) switches power to the IC through the V<sub>CC</sub> pin. In the CS-3351/CS-386, the Stator pin senses the voltage from the stator. This will keep the device powered while the voltage is high, and it also senses a stopped engine condition and drives the Lamp pin high after the stator timeout expires. The Lamp pin also goes high when an overvoltage condition is detected on the sense pin. This causes the darlington lamp drive transistor to switch on and pull current through the lamp. If the system voltage continues to increase, the field and lamp output turn off as in an overvoltage or load dump condition.

The SC or Short Circuit pin monitors the field voltage. If the drive output and the SC voltage are simultaneously high for a predetermined period, a short circuit condition is assumed and the output is disabled. The regulator is forced to a minimum short circuit duty cycle.

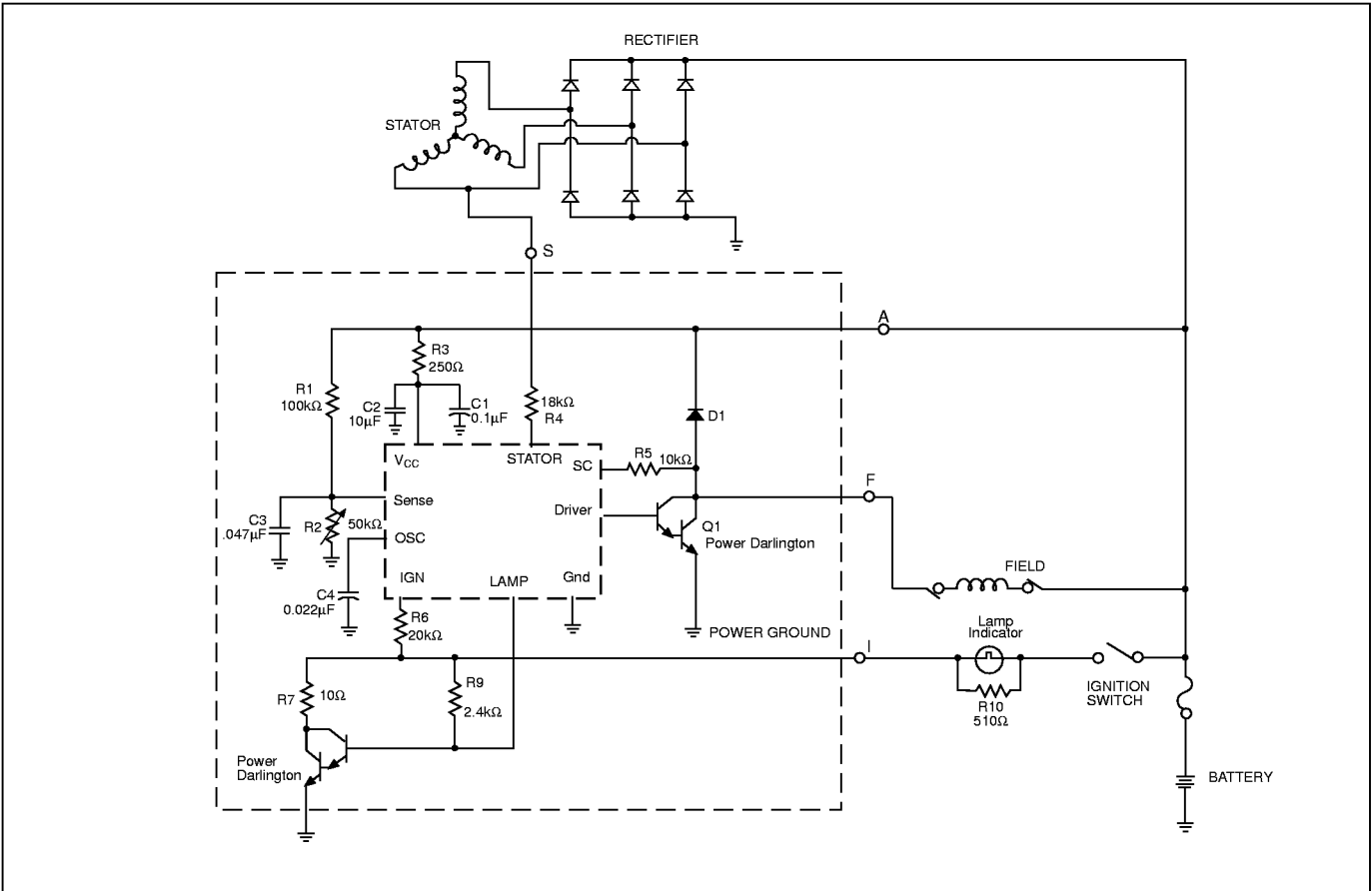

Figure 2. Typical Application Diagram

## Package Specification

CS-3341/3351/386/387

### PACKAGE DIMENSIONS IN mm (INCHES)

Lead Count	D			
	Metric		English	
	Max	Min	Max	Min
14L SO	8.74	8.53	.344	.336

### PACKAGE THERMAL DATA

Thermal Data		14L SO	
$R_{\theta JC}$	typ	30	$^{\circ}C/W$
$R_{\theta JA}$	typ	125	$^{\circ}C/W$

### SO Narrow

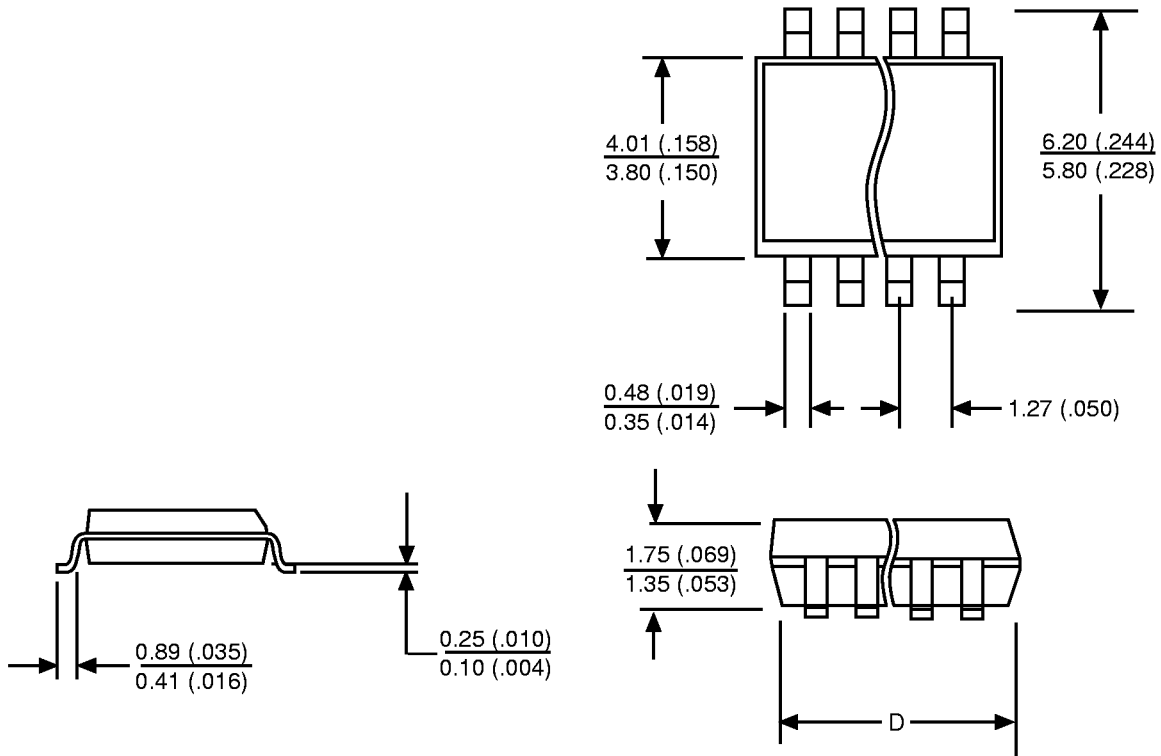

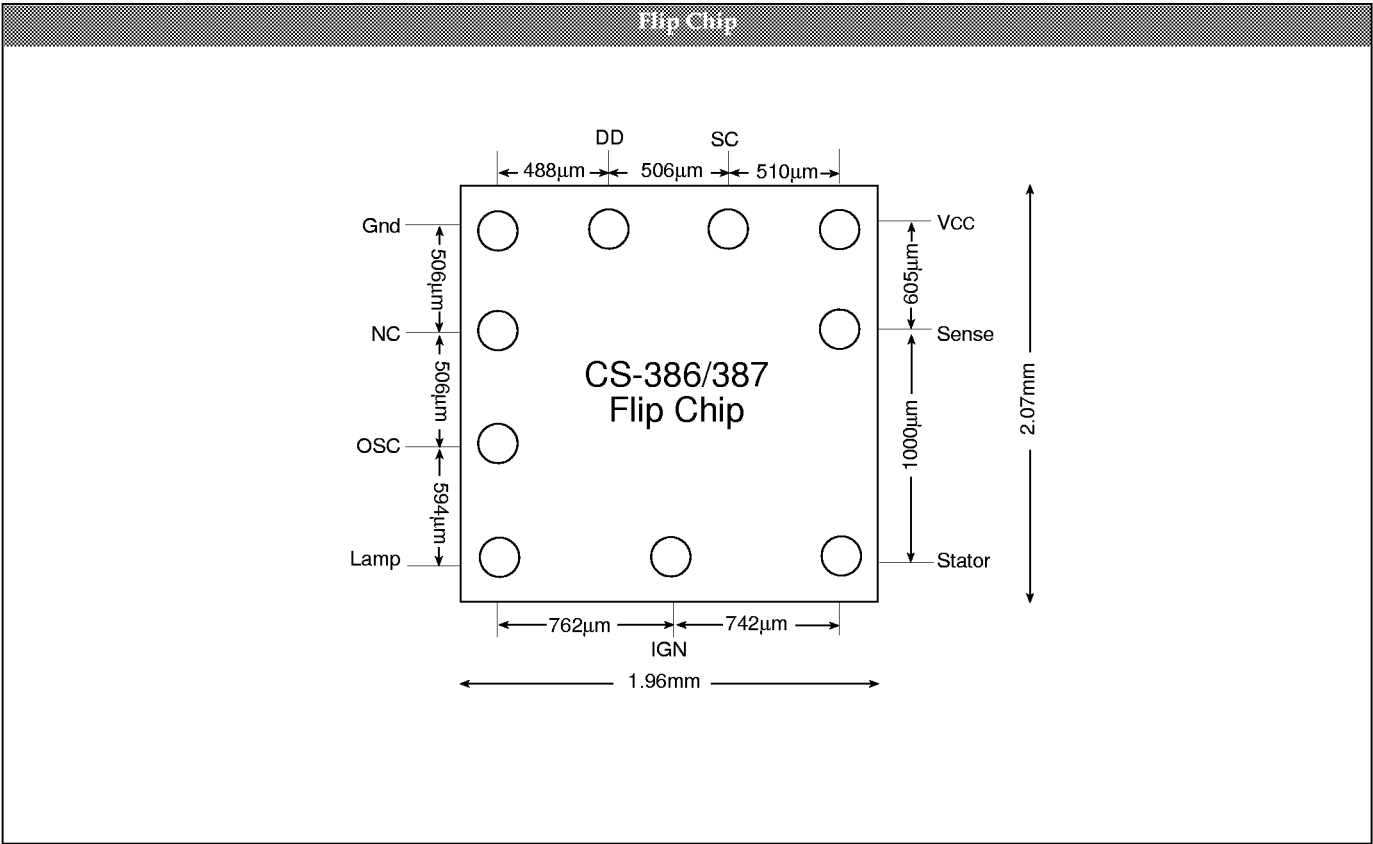

Solder Bump Locations, Bump Side Up

**Ordering Information**

Part Number	Description
CS-3341D14	14L SO
CS-3351D14	14L SO
CS-386	Flip Chip
CS-387	Flip Chip

Cherry Semiconductor Corporation reserves the right to make changes to the specifications without notice. Please contact Cherry Semiconductor Corporation for the latest available information.