

RED INDICATES ORIGINAL

DASH NO	CONN TYPE	IMPD (OHMS)	MATERIAL 5	ASSEMBLY PER	
-1	PL220	50	1-0442-025	TAI-A118	
-2	CJ220		1-0443-025		
-3	PL240		1-0446-025		
-4	CJ240		1-0445-025		
-5	BJ226	75	1-0472-025	TAI-123	
-6	BJ229		1-0473-025		
-7	BJ246		1-0046-025		
-8	BJ249	1-0047-025			
-9	UPL220	75	1-0468-025	TAI-D118	
-10	UPL240		1-0041-025		
-11	PL223	50	1-0009-025	TAI-A118	
-12	UPL223	75	1-0050-025	TAI-D118	
-13	PL240S	50	1-0446-025	TAI-A118	
-14	UPL240S	75	1-0041-025	TAI-D118	
-15	UBJ229		1-0488-025	TAI-123	
-16	UCJ220		1-0494-025	TAI-D118	
-17	UCJ240		1-0496-025		
-18	UBJ226		1-0489-025	TAI-123	
-19	UPLR220		1-0504-025	TAI-221	
-20	UPLFF220		1-0517-025	TAI-223	
-21	UBJ220		1-0515-025	TAI-D118	

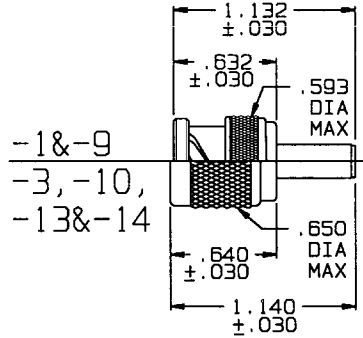

DATA CONTAINED IN THIS DOCUMENT IS PROPRIETARY TO TROMPETER ELECTRONICS, INC. AND SHALL NOT BE DISCLOSED, COPIED OR USED FOR REPRODUCTION OR MANUFACTURE WITHOUT EXPRESS WRITTEN PERMISSION.			REVISIONS		105-1313	SH
REV	ED	DESCRIPTION	DWN	APPROVED	DATE	
A	12703	UPDATED DRAWING SEE ECO	R L	[Signature]	3/2/99	

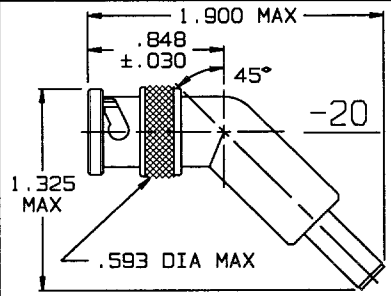
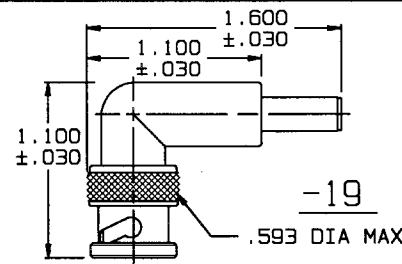
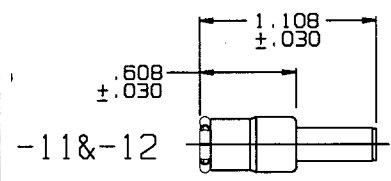
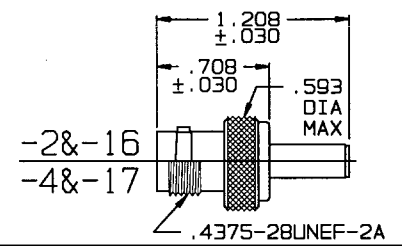

CENTER CONTACT CRIMP TOOLING

CONTACT TYPE	MILITARY 8 POINT INDENTER	COMMERCIAL HEX	COMMERCIAL 8 POINT INDENTER
50 OHM PIN CONTACT	M22520/1-01 BASIC TOOL WITH M22520/1-12 TURRET HEAD SELECTOR NO. 6	TEI CT4L BASIC TOOL WITH TEI C03-2 DIE, CLOSURE C (.068 HEX)	N/A
50 OHM SOCKET CONTACT	M22520/1-01 BASIC TOOL WITH M22520/1-12 TURRET HEAD SELECTOR NO. 6	TEI CT4L BASIC TOOL WITH TEI C03-2 DIE, CLOSURE C (.068 HEX)	N/A
75 OHM PIN CONTACT	N/A	TEI CT4L BASIC TOOL WITH TEI C03-2 DIE, CLOSURE D (.042 HEX)	TEI 010-0055
75 OHM SOCKET CONTACT	N/A	TEI CT4L BASIC TOOL WITH TEI C03-2 DIE, CLOSURE D (.042 HEX)	TEI 010-0088

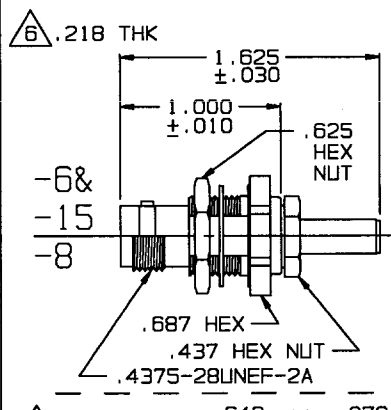
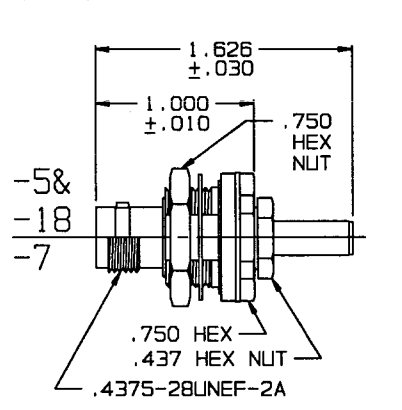

CRIMP SLEEVE TOOLING

CONNECTOR TYPE	MILITARY HEX	COMMERCIAL HEX
50 OR 75 OHM CONNECTORS	M22520/5-01 BASIC TOOL WITH M22520/5-07 DIE, CLOSURE A (.255 HEX)	TEI CT4L BASIC TOOL WITH TEI C03-2 DIE, CLOSURE B (.255 HEX)

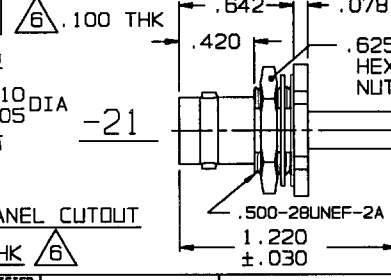
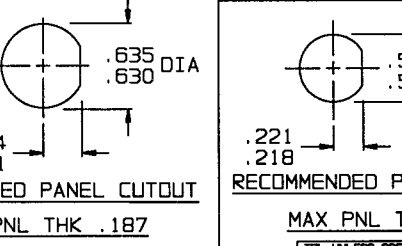

- EXAMPLE OF COMPLETE PART NO:
105-1313 - 1
BASIC PART NO. [] DASH NO (SEE TABLE 1)
- 50 & 75 OHM FULL CRIMP COAXIAL BNC/TNC CABLE PLUGS/ RECEPTACLE/INSULATED & NONINSULATED BULKHEAD MOUNT CABLE RECEPTACLE/PUSH-ON PLUG & 75 OHM BNC/TNC/PUSH-ON FULL CRIMP COAXIAL CABLE PLUG FOR TELEDYNE THERMATICS CABLE NO. E80083
- FINISH: TFS-1A (NICKEL)
- ALL DIM ARE IN INCHES

5 REPLACE CRIMP SLEEVE 8-1613-16 WITH CRIMP SLEEVE 805-0854

TOL UNLESS SPECIFIED		TROMPETER ELECTRONICS, INC.		220/240 SERIES-E80083	
.10X ± .005	.300X ± .005	DWN	R L 2/24/99	MATERIAL	CODE IDENT
.000X ± .005	ANGLES	CHK	[Signature] 2/25/99	14949	DRAWING NO.
		ENGR			105-1313
		APPR	[Signature] 3/11/99	SCALE	DATE 8/15/90
NEXT ASSY					SHEET