

- SPI-2 and SPI-3 Compliant
- 2.85-V Regulated Output Voltage with 1.4% Tolerance
- Provides Current for up to 27 Lines of Active Termination for SCSI Buses
- -750-mA Sourcing Current for Termination
- 300-mA Sinking Current for Active Negation Drivers
- 0.9-V Dropout Voltage Regulator at 750 mA and 2.75 V Output
- 100- A Supply Current in Disconnect Mode
- Current Limit and Thermal Shutdown Protection
- Low Thermal Resistance Surface Mount Packages

simplified block diagram

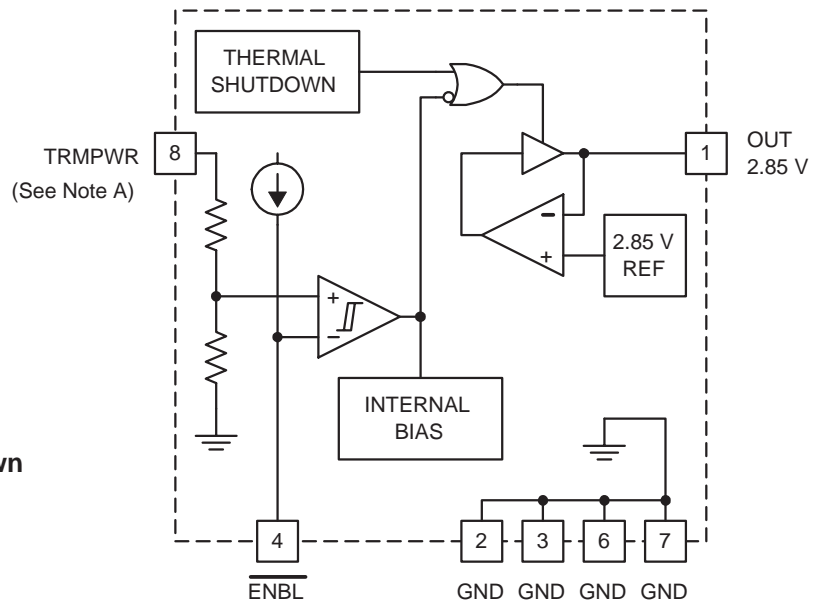

Note A: 4.0 V TO 6.0 V (4.75 V NOMIMAL)

description

The UC560 provides current for up to 27 lines of active termination for a SCSI (small computers systems interface) parallel bus. The SCSI standard requires active termination at both ends of the cable. The UC560 is based on the UC5603 and UC5613 SCSI active terminators. It uses the voltage regulator and internal logic circuits of those parts, but has no termination circuits. The UC560 provides greater source current-drive capability compared to the UC5603 and UC5613.

The UC560 sink current maintains regulation with all active-negation drivers negated. It provides a disconnect feature which disables the regulator to greatly reduce standby power. Internal circuit trimming is utilized for a 1.4% tolerance output voltage. Other features include thermal shutdown and current limit for short circuit conditions.

The UC560 is available in low-thermal-resistance versions of the industry standard 8-pin power SOIC, 5-pin TO-220 and 5-pin TO-263.

AVAILABLE OPTIONS

T _A	PACKAGED DEVICES		
	SOIC (DP) [†]	TO-220 (T)	TO-263 (TD)
0°C to 70°C	UC560DP	UC560T	UC560TD

[†] The DP package is available taped and reeled. Add R suffix to device type (e.g. UC560DPTR) to order quantities of 3000 devices per reel.



Please be aware that an important notice concerning availability, standard warranty, and use in critical applications of Texas Instruments semiconductor products and disclaimers thereto appears at the end of this data sheet.

UC560

27-LINE SCSI SOURCE/SINK REGULATOR

SLUS213A – APRIL 1998 – REVISED AUGUST 2000

TO-220-5 TD PACKAGE
(FRONT VIEW)

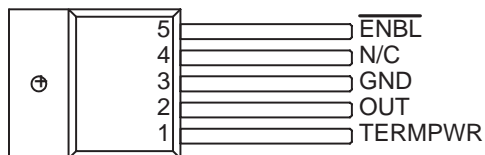

TO-263-5 T PACKAGE
(FRONT VIEW)

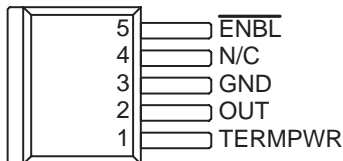

DP PACKAGE
(TOP VIEW)

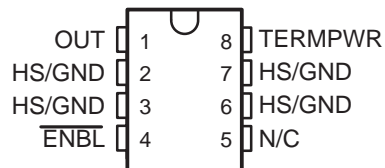

NOTE 1: For DP package, pins 2, 3, 6 and 7 are heat sinking pins. Pin 2 is the connect point for electrical ground.

NOTE 2: For T and TD packages, TAB is ground.

NOTE 3: For all packages, N/C is no connection.

absolute maximum ratings over operating free-air temperature (unless otherwise noted)^{† ‡}

Input voltage,	
TERMPWR	7 V
ENBL	-0.3 V to TERMPWR + 0.3 V
Regulator Output Current	1.4 A
Power Dissipation	2.5 W
Storage Temperature	-65°C to 150°C
Junction Temperature	-55°C to 150°C
Lead Temperature (Soldering, 10 seconds)	300°C

[†] Stresses beyond those listed under "absolute maximum ratings" may cause permanent damage to the device. These are stress ratings only, and functional operation of the device at these or any other conditions beyond those indicated under "recommended operating conditions" is not implied. Exposure to absolute-maximum-rated conditions for extended periods may affect device reliability.

[‡] Currents are positive into and negative out of the specified terminal. Consult the Packaging Section of the Databook for thermal limitations and considerations of the package.

recommended operating conditions

	MIN	MAX	UNIT
Input voltage, TERMPWR	4.0	6.0	V
Operating virtual junction temperature, T_J [¶]	0	70	°C

[¶] It is not recommended that the device operate under conditions beyond those specified in this table for extended periods of time.

UC560

27-LINE SCSI SOURCE/SINK REGULATOR

SLUS213A – APRIL 1998 – REVISED AUGUST 2000

electrical characteristics over recommended operating free-air temperature range, $T_A = 0\text{ C to }70\text{ C}$, $TERMPWR = 4.75\text{ V}$, $ENBL = 0\text{ V}$, $C_{OUT} = 4.7\text{ F}$, $C_{TERMPWR} = 4.7\text{ F}$, $T_A = T_J$, unless otherwise specified.

PARAMETER	TEST CONDITIONS	MIN	TYP	MAX	UNITS
Supply Current Section					
TERMPWR supply current	No load		18	25	mA
	$I_{OUT} = -700\text{ mA}$		710	750	mA
Power down mode	$ENBL = 2.0\text{ V}$		100	140	μA
Regulator Section					
Regulator output voltage	25°C, No load	2.81	2.85	2.89	V
Load regulation	$I_{OUT} = 300\text{ mA to }-750\text{ mA}$ See Note 1		25	30	mV
Line regulation	$TERMPWR = 4.0\text{ V to }6.0\text{ V}$ No load, See Note 1		10	20	mV
Dropout voltage	$I_{OUT} = -750\text{ mA}$ $V_{OUT} = 2.75\text{ V}$		0.9	1.2	V
Short circuit current	$V_{OUT} = 0.0\text{ V}$		-1.3	-0.85	A
Sinking current	$V_{OUT} = 3.5\text{ V}$		500	600	mA
	$ENBL = 2.0\text{ V}$ $V_{OUT} = 3.0\text{ V}$		1	2	mA
Thermal shutdown	See Note 2		170		°C
Thermal shutdown hysteresis	See Note 2		10		°C
Shutdown Section					
ENBL threshold		1.1	1.4	1.7	V
Threshold hysteresis			100		mV
ENBL output current		-15	-10		μA

- NOTES: 1. Tested at a constant junction temperature by low duty cycle pulse testing.
2. Ensured by design. Not production tested.

pin descriptions

ENBL: (Enable pin) The \overline{ENBL} function is active low, and the pin sources 10 μA (typical) when at ground and $TERMPWR$ is between 4 V and 6 V. The part goes into disable mode if \overline{ENBL} is above 1.4 V (typical), and returns to enable mode when \overline{ENBL} drops below 1.3 V typical. The part also greatly reduces $TERMPWR$ current when disabled (100 μA typical).

GND: Ground pin.

OUT: (2.85-V regulated output voltage pin) The part is internally current limited for both sinking and sourcing current to prevent damage. When the part is in disabled mode (\overline{ENBL} 1.4 V typical), the output goes to 0 V with no external supply source on OUT. The IC current sinks if there is an external supply voltage applied to OUT when in disabled mode. For best performance, a 4.7- μF low-ESR capacitor is recommended.

TERMPWR: (Supply voltage pin) The pin should be decoupled with at least a 2.2- μF low-ESR output capacitor. For best performance, a 4.7- μF low-ESR capacitor is recommended. Lead lengths should be kept at a minimum.



UC560 27-LINE SCSI SOURCE/SINK REGULATOR

SLUS213A – APRIL 1998 – REVISED AUGUST 2000

APPLICATION INFORMATION

TYPICAL SCSI BUS CONFIGURATION
(18 TERMINATION LINES)

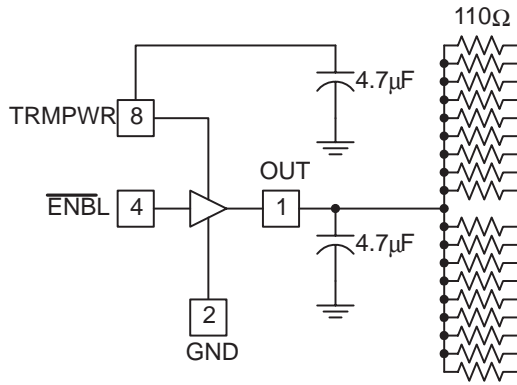

Figure 1

UDG-00075

TYPICAL WIDE SCSI BUS CONFIGURATION
(27 TERMINATION LINES)

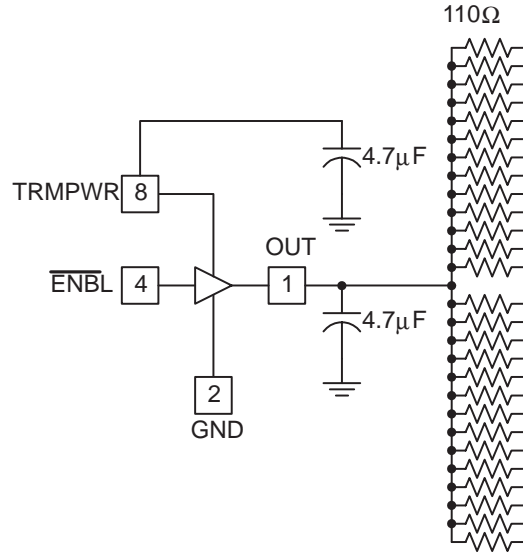

Figure 2

UDG-00076

TYPICAL CHARACTERISTICS

OUTPUT VOLTAGE
vs
TEMPERATURE

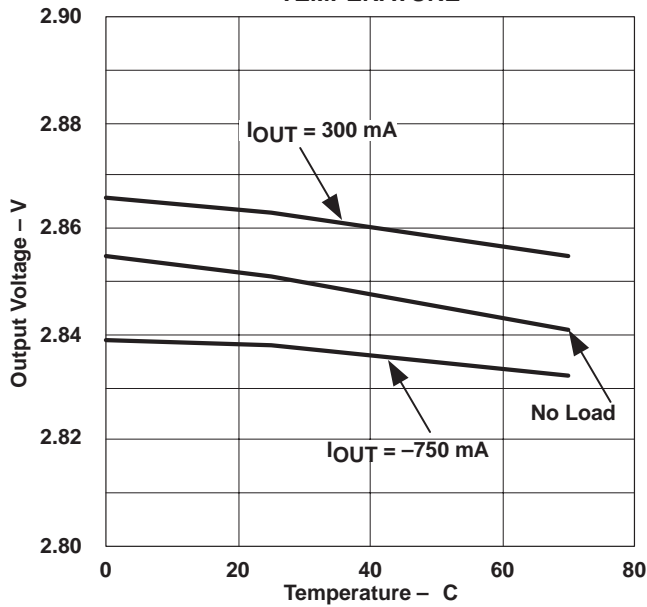

Figure 3

DROPOUT VOLTAGE
vs
TEMPERATURE

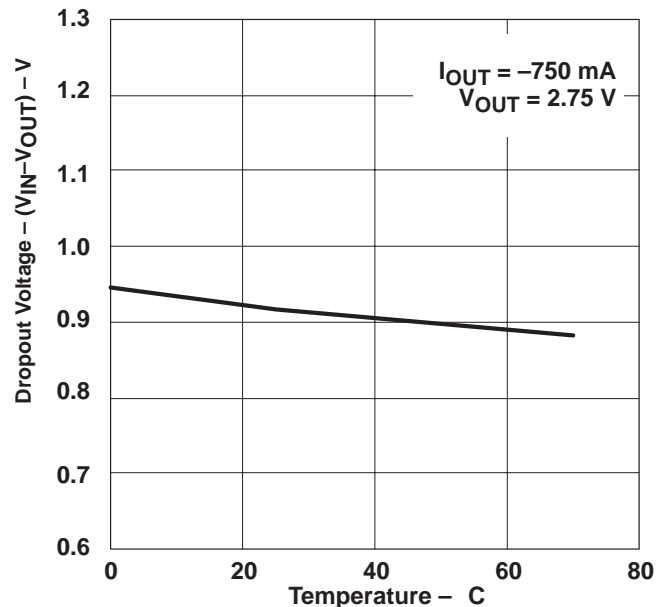

Figure 4

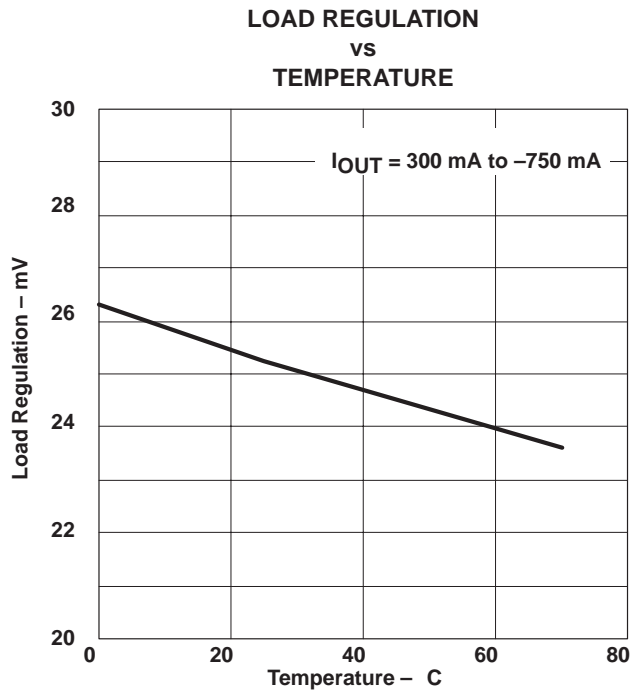

Figure 5

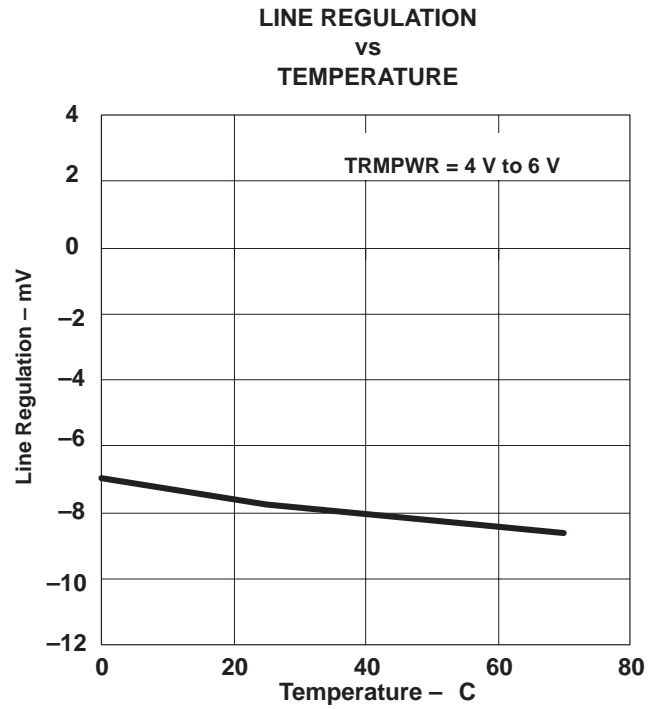

Figure 6

IMPORTANT NOTICE

Texas Instruments and its subsidiaries (TI) reserve the right to make changes to their products or to discontinue any product or service without notice, and advise customers to obtain the latest version of relevant information to verify, before placing orders, that information being relied on is current and complete. All products are sold subject to the terms and conditions of sale supplied at the time of order acknowledgment, including those pertaining to warranty, patent infringement, and limitation of liability.

TI warrants performance of its semiconductor products to the specifications applicable at the time of sale in accordance with TI's standard warranty. Testing and other quality control techniques are utilized to the extent TI deems necessary to support this warranty. Specific testing of all parameters of each device is not necessarily performed, except those mandated by government requirements.

Customers are responsible for their applications using TI components.

In order to minimize risks associated with the customer's applications, adequate design and operating safeguards must be provided by the customer to minimize inherent or procedural hazards.

TI assumes no liability for applications assistance or customer product design. TI does not warrant or represent that any license, either express or implied, is granted under any patent right, copyright, mask work right, or other intellectual property right of TI covering or relating to any combination, machine, or process in which such semiconductor products or services might be or are used. TI's publication of information regarding any third party's products or services does not constitute TI's approval, warranty or endorsement thereof.