

ASJ

DATA SHEET

Thick Film Chip Resistors Automotive Grade

AR Series ($\geq 1\Omega$)

0.1% TO 5%, TCR -200 TO +600

SIZE: 01005/0201/0402/0603/0805/1206/1210/2010/2512

RoHS-Compliant

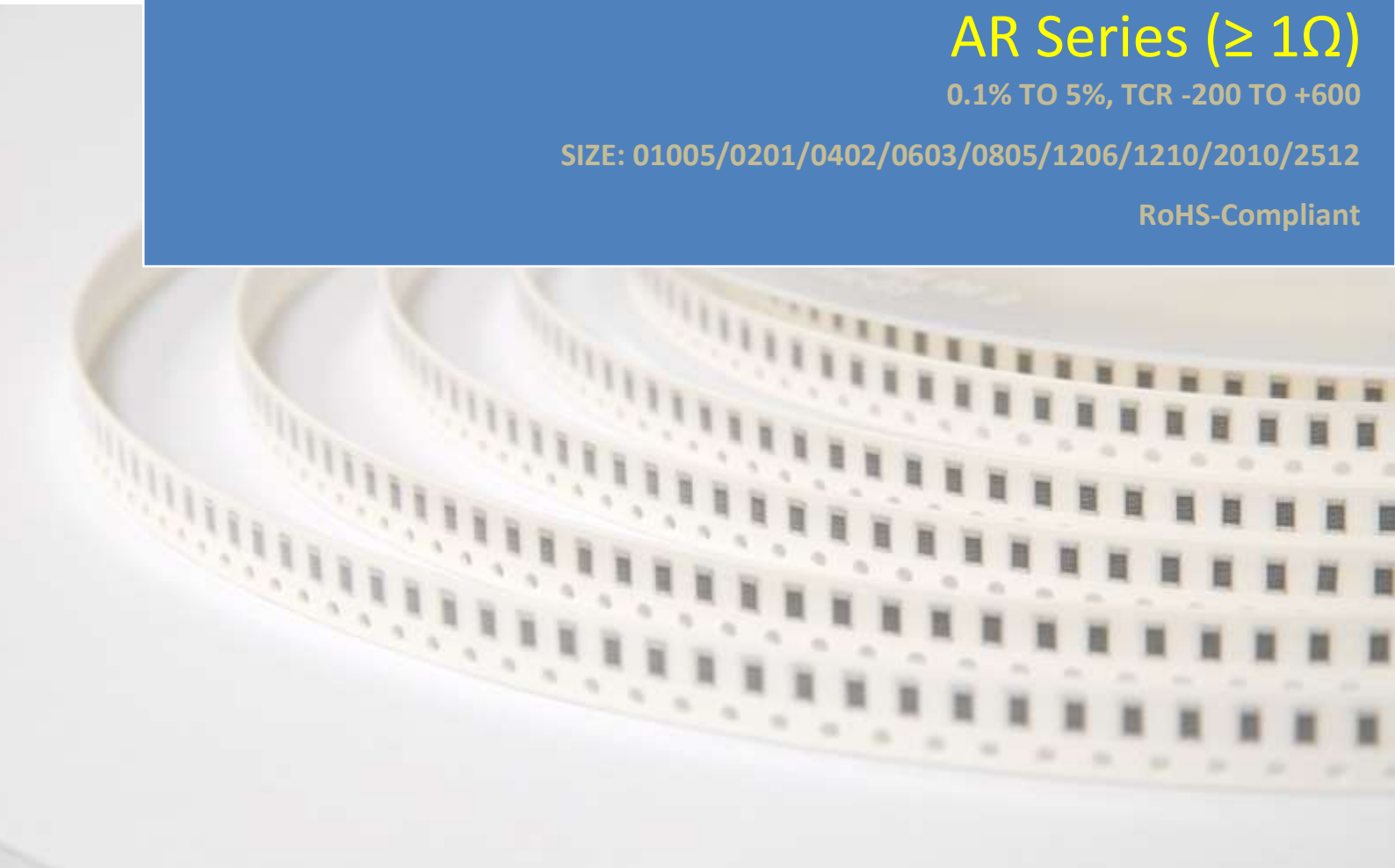

THICK FILM CHIP RESISTORS AUTOMOTIVE GRADE

AR Series ($\geq 1\Omega$)

DS-ENG-021

Page: 2 of 17

1. SCOPE

- 1.1 This specification is applicable to Lead-free and Halogen-free of RoHS Directive for AR series thick film chip resistor.
- 1.2 This product is for automotive electronic application.
- 1.3 AR03/AR05 AEC-Q200 qualified, grade 1.
Other types AEC-Q200 qualified, grade 0.

2. PART NUMBERING SYSTEM

Part Numbering is made in accordance with the following system:

AR	10	-	100	-	J	K
Type	Size		Nominal Resistance		Resistance Tolerance	Packaging
Thick Film Chip Resistor for Automotive Grade	03(01005) 05(0201) 10(0402) 16(0603) 21(0805) 32(1206) 40(1210) 50(2010) 63(2512)		3 Digit Ex. $10\Omega=100$ $4.7\Omega=4R7$ Jumper=000		B= $\pm 0.1\%$ D= $\pm 0.5\%$ F= $\pm 1\%$ G= $\pm 2\%$ J= $\pm 5\%$ Z=Zero ohm *For 3 digit only Ex. AR21-000-ZL	E=4,000 pcs Lead Free L=5,000 pcs Lead Free K=10,000 pcs Lead Free Y=20,000 pcs Lead Free N=50,000 pcs Lead Free Refer to item 7.3.2
			4 Digit EX. $10.2\Omega=10R2$ $10K\Omega=1002$			
			Jumper	000		

3. RATING

3.1 Rated Power

3.1.1 Resistor Rated Power

Type	Rated Power at 70°C	Max. Working Voltage	Max. Overload Voltage
AR03 (01005)	$\frac{1}{32}$ W	15V	30V
AR05 (0201)	$\frac{1}{20}$ W	25V	50V
AR10 (0402)	$\frac{1}{16}$ W	50V	100V
AR16 (0603)	$\frac{1}{10}$ W	75V	150V
AR21 (0805)	$\frac{1}{8}$ W	150V	300V
AR32 (1206)	$\frac{1}{4}$ W	200V	400V
AR40 (1210)	$\frac{1}{2}$ W	200V	400V
AR50 (2010)	$\frac{3}{4}$ W	200V	400V
AR63 (2512)	1W	200V	400V



THICK FILM CHIP RESISTORS AUTOMOTIVE GRADE

AR Series ($\geq 1\Omega$)

DS-ENG-021

Page: 3 of 17

3.2 Power Derating Characteristics

Type	AR03/05	Other
Operating Temperature Range	- 55°C ~ + 125°C	- 55°C ~ + 155°C
Explain	For resistors operated in ambient temperatures above 70°C, power rating shall be derated in accordance with figure below.	For resistors operated in ambient temperatures above 70°C, power rating shall be derated in accordance with figure below.
Figure	<p>The graph for AR03/05 resistors shows a constant power rating of 100% from -55°C to 70°C. Above 70°C, the power rating decreases linearly, reaching 0% at 125°C. The x-axis ranges from -55 to 160°C, and the y-axis ranges from 0 to 100%.</p>	<p>The graph for Other resistors shows a constant power rating of 100% from -55°C to 70°C. Above 70°C, the power rating decreases linearly, reaching 0% at 155°C. The x-axis ranges from -55 to 160°C, and the y-axis ranges from 0 to 100%.</p>

3.3 Standard Atmospheric Condition

Unless otherwise specified, the standard range of atmospheric conditions for making measurements and tests is as follows:

Ambient Temperature = + 5°C to +35°C

Relative Humidity = < 85% RH

Air Pressure = 86 kPa to 106kPa

If there may be any doubt about the results, measurement shall be made within the following limits:

Ambient Temperature = $20 \pm 2^\circ\text{C}$

Relative Humidity = 60 to 70% RH

Air Pressure = 86 kPa to 106kPa

3.4 Operating Temperature Range -55°C to +155°C (01005/0201: -55°C to +125°C)

3.5 Storage Temperature Range -5°C to + 40°C / < 85% RH

3.6 Flammability Rating Tested in accordance to UL-94, V-0

3.7 Moisture Sensitivity Level Rating: Level 1

3.8 Product Assurance

ASJ resistor shall warranty 24 months from manufacturing date with control condition.

3.9 ASJ resistors are RoHS-compliant in accordance to RoHS Directive.



Product Specification

Towards Excellence in Quality, Service & Innovation

THICK FILM CHIP RESISTORS AUTOMOTIVE GRADE

AR Series (≥ 1Ω)

DS-ENG-021

Page: 4 of 17

3.10 Resistance, Resistance Tolerance and Temperature Coefficient of Resistance.

Type	Rated Power at 70°C	Max. Working Voltage	Max. Overload Voltage	T.C.R (ppm/°C)	Resistance Range				JUMPER (0Ω) Rated Power		JUMPER (0Ω) Resistance Value	
					B(±0.1%) E-24、E-96	D(±0.5%) E-24、E-96	F(±1%) E-24、E-96	G(±2%)、J(±5%) E-24	Z (±5%)	F (±1%)	Z (±5%)	F (±1%)
AR03 (01005)	$\frac{1}{32}$ W	15V	30V	-200	-----	-----	1Ω≤R<10Ω		0.5A	0.5A	100mΩ MAX	100mΩ MAX
				+600	-----	-----	10Ω≤R≤10MΩ					
AR05 (0201)	$\frac{1}{20}$ W	25V	50V	-200	-----	1Ω≤R<10Ω	1Ω≤R<10Ω	1Ω≤R<10Ω	0.5A	---	50mΩ MAX.	---
				+400	47Ω≤R≤1MΩ	10Ω≤R≤10MΩ	10Ω≤R≤10MΩ	10Ω≤R≤10MΩ				
AR10 (0402)	$\frac{1}{16}$ W	50V	100V	±100	100Ω≤R≤1MΩ	10Ω≤R≤1MΩ	10Ω≤R≤22MΩ	10Ω≤R≤22MΩ	1A	1.33A	50mΩ MAX.	35mΩ MAX.
				±200	-----	-----	1Ω≤R<10Ω	1Ω≤R<10Ω				
AR16 (0603)	$\frac{1}{10}$ W	75V	150V	±100	100Ω≤R≤1MΩ	10Ω≤R≤1MΩ	10Ω≤R≤22MΩ	10Ω≤R≤22MΩ	1A	2A	50mΩ MAX.	25mΩ MAX.
				±200	-----	1Ω≤R<10Ω	1Ω≤R<10Ω	1Ω≤R<10Ω				
AR21 (0805)	$\frac{1}{8}$ W	150V	300V	±100	100Ω≤R≤1MΩ	10Ω≤R≤10MΩ	10Ω≤R≤27MΩ	10Ω≤R≤27MΩ	2A	2.5A	50mΩ MAX.	20mΩ MAX.
				±200	-----	1Ω≤R<10Ω	1Ω≤R<10Ω	1Ω≤R<10Ω				
AR32 (1206)	$\frac{1}{4}$ W	200V	400V	±100	10Ω≤R≤1MΩ	10Ω≤R≤10MΩ	10Ω≤R≤27MΩ	10Ω≤R≤27MΩ	2A	3.5A	50mΩ MAX.	20mΩ MAX.
				±200	3Ω≤R<10Ω	1Ω≤R<10Ω	1Ω≤R<10Ω	1Ω≤R<10Ω				
AR40 (1210)	$\frac{1}{2}$ W	200V	400V	±100	100Ω≤R≤1MΩ	10Ω≤R≤10MΩ	10Ω≤R≤27MΩ	10Ω≤R≤27MΩ	2A	4A	50mΩ MAX.	20mΩ MAX.
				±200	-----	-----	1Ω≤R<10Ω	1Ω≤R<10Ω				
AR50 (2010)	$\frac{3}{4}$ W	200V	400V	±100	100Ω≤R≤1MΩ	10Ω≤R≤10MΩ	10Ω≤R≤20MΩ	10Ω≤R≤20MΩ	2A	5A	50mΩ MAX.	20mΩ MAX.
				±200	-----	-----	1Ω≤R<10Ω	1Ω≤R<10Ω				
AR63 (2512)	1W	200V	400V	±100	100Ω≤R≤1MΩ	10Ω≤R≤10MΩ	10Ω≤R≤20MΩ	10Ω≤R≤20MΩ	2A	7A	50mΩ MAX.	20mΩ MAX.
				±200	-----	-----	1Ω≤R<10Ω	1Ω≤R<10Ω				
Operating Temperature Range				-55°C ~ +155°C (01005/0201: -55°C ~ +125°C)								

3.11 Voltage Rating.

Rated Voltage: The resistor shall have a DC continuous working voltage or a rms. AC continuous working voltage at commercial-line frequency and wave form corresponding to the power rating, as determined from the following:

$$E = \sqrt{R \times P}$$

E= Rated voltage (v)
P= Power rating (w)
R= Nominal resistance(Ω)

3.12 All product, product specifications and data are subject to change without notice to improve reliability, function or design or otherwise.



4. MARKING ON PRODUCT

The nominal resistance shall be marked on the surface of each resistor.

Type		Resistance Range	Tolerance $\leq 1\%$	Tolerance $> 1\%$
Single	Sizes: 01005、0201、0402	All	No Marking	
		Jumper=0 Ω		
	Size: 0603 (Except CPS16)	$< 1\Omega$	4-digits Marking	4-digits Marking
		$\geq 1\Omega$	3-digits Marking	3-digits Marking
		Jumper=0 Ω	3-digits Marking	1-digit Marking
	Sizes: 0603 (CPS16)	All	Marked as a square	
	Sizes: 0805、1206、1210 1812、2010、2512 0508、0612、1218 1020、1225	$< 1\Omega$	4-digits Marking	4-digits Marking
		$\geq 1\Omega$	4-digits Marking	3-digits Marking
		Jumper=0 Ω	3-digits Marking	1-digit Marking

4.1 Numeric Numbering

4.1.1 5% Tolerance: **Three Numerals Marking**

First 2 digits are significant figures; third digit is number of zeros. Letter R is decimal point.

Example

Nominal Resistance	Marking	Remarks
1 Ω	1R0	$1 \times 10^0 = 1$
10 Ω	100	$10 \times 10^0 = 10$
100 Ω	101	$10 \times 10^1 = 100$
4.7K Ω	472	$47 \times 10^2 = 4700$
47K Ω	473	$47 \times 10^3 = 47000$
470K Ω	474	$47 \times 10^4 = 470000$
4.7M Ω	475	$47 \times 10^5 = 4700000$

4.1.2 1% Tolerance : **Four Numerals Marking**

First 3 digits are significant figures; fourth digit is number of zeros.

Examples:

Nominal Resistance	Marking	Remarks
1 Ω	1R00	$1 \times 10^0 = 1$
10 Ω	10R0	$10 \times 10^0 = 10$
100 Ω	1000	$100 \times 10^0 = 100$
4.7K Ω	4701	$470 \times 10^1 = 4700$
47K Ω	4702	$470 \times 10^2 = 47000$
470K Ω	4703	$470 \times 10^3 = 470000$
1M Ω	1004	$100 \times 10^4 = 1000000$

4.1.3 0603 1% Tolerance: **Three Character E-96 Marking Standard.**

The first 2 digits for the 3 digits E-96 part marking standard, (Refer Table 2 & 3).

The third character is a letter multiplier:

Nominal resistance	Marking	Remark
33.2 Ω	51 X	332 X $10^{-1} \Omega$
150 Ω	18 A	150 X $10^0 \Omega$
4.99K Ω	68 B	499 X $10^1 \Omega$
10.2K Ω	02 C	102 X $10^2 \Omega$
100K Ω	01 D	100 X $10^3 \Omega$

4.1.3.1 EIA-96 Marking Scheme

Table 2 Significant figures

Significant Figures	Symbol	Significant Figures	Symbol	Significant Figures	Symbol	Significant Figures	Symbol
100	01	178	25	316	49	562	73
102	02	182	26	324	50	576	74
105	03	187	27	332	51	590	75
107	04	191	28	340	52	604	76
110	05	196	29	348	53	619	77
113	06	200	30	357	54	634	78
115	07	205	31	365	55	649	79
118	08	210	32	374	56	665	80
121	09	215	33	383	57	681	81
124	10	221	34	392	58	698	82
127	11	226	35	402	59	715	83
130	12	232	36	412	60	732	84
133	13	237	37	422	61	750	85
137	14	243	38	432	62	768	86
140	15	249	39	442	63	787	87
143	16	255	40	453	64	806	88
147	17	261	41	464	65	825	89
150	18	267	42	475	66	845	90
154	19	274	43	487	67	866	91
158	20	280	44	499	68	887	92
162	21	287	45	511	69	909	93
165	22	294	46	523	70	931	94
169	23	301	47	536	71	953	95
174	24	309	48	549	72	976	96

Table 3 Multiplier

Symbol	Multiplier	Symbol	Multiplier
A	10^0	G	10^6
B	10^1	H	10^7
C	10^2	X	10^{-1}
D	10^3	Y	10^{-2}
E	10^4		
F	10^5		

5. DIMENSION, CONSTRUCTION AND MATERIAL

5.1 Dimension

Unit:mm

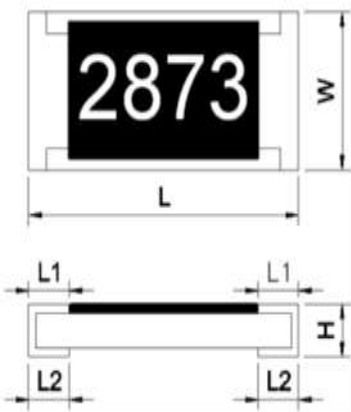

Dimension		L	W	H	L1	L2
Type	Size Code					
AR03	01005	0.40±0.02	0.20±0.02	0.13±0.02	0.10±0.03	0.10±0.03
AR05	0201	0.60±0.03	0.30±0.03	0.23±0.03	0.10±0.05	0.15±0.05
AR10	0402	1.00±0.10	0.50±0.05	0.30±0.05	0.20±0.10	0.25±0.10
AR16	0603	1.60±0.10	0.80±0.10	0.45±0.10	0.30±0.15	0.30±0.15
AR21	0805	2.00±0.10	1.25±0.10	0.50±0.10	0.35±0.20	0.35±0.15
AR32	1206	3.05±0.10	1.55±0.10	0.50±0.10	0.45±0.20	0.35±0.15
AR40	1210	3.05±0.10	2.55±0.10	0.55±0.10	0.50±0.20	0.50±0.20
AR50	2010	5.00±0.20	2.50±0.20	0.55±0.10	0.60±0.20	0.60±0.20
AR63	2512	6.30±0.20	3.20±0.20	0.55±0.10	0.60±0.20	0.60±0.20

5.2 Construction

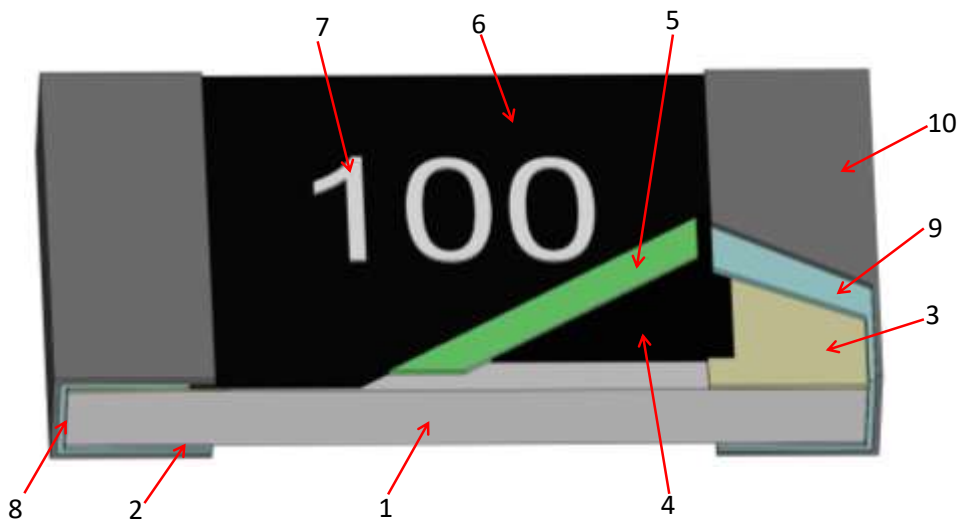

1	Ceramic substrate	6	2nd Protective coating
2	Bottom inner electrode	7	Marking
3	Top inner electrode	8	Terminal inner electrode
4	Resistive layer	9	Ni plating
5	1st Protective coating	10	Sn plating

5.3. Plating Thickness

Ni : $\geq 2 \mu\text{m}$

Sn (Tin) : $\geq 3 \mu\text{m}$

Sn (Tin) : Matte Sn

THICK FILM CHIP RESISTORS AUTOMOTIVE GRADE

AR Series ($\geq 1\Omega$)

DS-ENG-021

Page: 8 of 17

6. RELIABILITY TEST

Item	Conditions	Specifications	
		Resistors	Jumper
High Temperature Exposure (Storage)	Put the specimens in the chamber with temperature of $155\pm 3^{\circ}\text{C}$ for 1000 hours. Then take them out to stabilize in room temperature for 24 ± 4 hr or more, and measure of its resistance variance rate. Experiment evidence: AEC-Q200	01005: $\Delta R = \pm 2.0\%$ Others: 0.1%、0.5%、1% : $\Delta R = \pm 1.0\%$ 2%、5% : $\Delta R = \pm 2.0\%$	Refer to item 3.10
Temperature Cycling	Put the specimens in the high & low temperature test chamber with temperature varies from -55°C to 155°C for 15 minutes and total 1000 cycles. Then take them out to stabilize in room temperature for 24 ± 4 hr or more, and measure of its resistance variance rate. Experiment evidence: AEC-Q200	$\Delta R = \pm 2.0\%$	Refer to item 3.10
Short Time Overload	Applied 2.5 times rated voltage for 5 seconds and release the load for about 30 minutes, then measure its resistance variance ate. (Rated voltage refer to item 3.10 general specifications) Refer to JIS-C5201-1 4.13	01005: $\Delta R = \pm 2.0\%$ Others: 0.1%、0.5%、1% : $\Delta R = \pm 1.0\%$ 2%、5% : $\Delta R = \pm 2.0\%$	Refer to item 3.10
Humidity Bias	Solder the specimens on the test PCB and put them into the constant temperature humidity chamber with $85\pm 2^{\circ}\text{C}$ and $85\pm 5\% \text{RH}$. Then apply the test voltage that calculates based on the 10% of rated power for 1000hrs. Then take them out to stabilize in room temperature for 24 ± 4 hr or more, and measure of its resistance variance rate. Experiment evidence: AEC-Q200	01005: $\Delta R = \pm 5.0\%$ Others: 0.1%、0.5%、1% : $\Delta R = \pm 2.0\%$ 2%、5% : $\Delta R = \pm 3.0\%$	Refer to item 3.10
High Temperature Operating Life	Solder the specimens on the test PCB and Put them in the chamber with temperature of $70\pm 3^{\circ}\text{C}$ and load the voltage for 1000 hours. Then take them out to stabilize in room temperature for 24 ± 4 hr or more, and measure of its resistance variance rate. Note: The input voltage shall refer to the power de-rating curve (referring to page 3, No.3.2) Experiment evidence: AEC-Q200	01005: $\Delta R = \pm 5.0\%$ Others: 0.1%、0.5%、1% : $\Delta R = \pm 2.0\%$ 2%、5% : $\Delta R = \pm 3.0\%$	Refer to item 3.10
Resistance to Soldering Heat	The specimens are tested in the test condition K (reflow) and measure its resistance variance rate. Time above : 217°C , 60sec - 150sec. Experiment evidence AEC-Q200	01005: $\Delta R = \pm 2.0\%$ Others: $\Delta R = \pm 1.0\%$	Refer to item 3.10

THICK FILM CHIP RESISTORS AUTOMOTIVE GRADE

AR Series ($\geq 1\Omega$)

DS-ENG-021

Page: 9 of 17

Item	Conditions	Specifications	
		Resistors	Jumper
ESD	Put the specimens on the test fixture and two (2) discharges (2KVDC) shall be applied to each PUT, one (1) with a positive polarity and one (1) with a negative polarity. Afterwards, the specimens stabilize for 30min or more and measure of its resistance variance rate. The test is performed with direct contact and regular discharge mode. The resistor and capacitor used on the spearhead is 2000 Ω and 150pF respectively. Experiment evidence AEC-Q200	$\Delta R = \pm 3.0\%$	Refer to item 3.10
Solderability	Test method: Test item 1 (solder pot test): Method B Precondition: The specimens are subjected to 155°C dry bake for 4hrs \pm 15min. The specimens are immersed into the flux first, then fully immersed into the solder pot, at a temperature of 245 \pm 5°C for 5 $^{+0}_{-0.5}$ sec. Then rinse with water and observe the soldering coverage under the microscope. Test item 2 (Leaching test): Method D The specimens are immersed into the flux first, then fully immersed into the solder pot, at a temperature of 260 \pm 5°C for 30 $^{+0}_{-0.5}$ sec. Then rinse with water and observe the soldering coverage under the microscope. Experiment evidence AEC-Q200	1. Soldering coverage over 95% 2. At the edge of terminal, the object underneath (e.g. white ceramic) shall not expose.	
Electrical Characterization	$TCR(ppm/^{\circ}C) = \frac{(R2 - R1)}{R1(T2 - T1)} \times 10^6$ R1: Resistance at room temperature (Ω) R2: Resistance at -55°C or +125°C (Ω) T1: Room temperature ($^{\circ}C$) T2: Temperature -55°C or +125°C Experiment evidence: AEC-Q200	Refer to item 3.10	NA
Board Flex (Bending Test)	Solder the specimens on the test PCB and put the PCBA onto the Bending Tester. Add force at the central part of PCB, and the duration of the applied forces shall be 60 (+ 5) Sec. Measure of its resistance variance rate in load. Bending depth (D) : AR10、16、21=5mm AR03、05、32、40=3mm AR50、63=2mm Experiment evidence: AEC-Q200	$\Delta R = \pm 1.0\%$	Refer to item 3.10
Sulfuration Test	Class A Put the tested resistor in Sulfur vapor, at a temperature of 60 \pm 2°C for 1000hrs. Refer to ASTM-B-809-95 & EIA977	$\Delta R = \pm 4.0\%$	Refer to item 3.10

6.1 Soldering Profile



Product Specification

Towards Excellence in Quality, Service & Innovation

Technical application note: (This is for recommendation, customer please perform adjustment according to the actual application)

6.1.1 Lead-Free Double Wave Soldering Profile. (This applies to 0603 size inclusive above product)

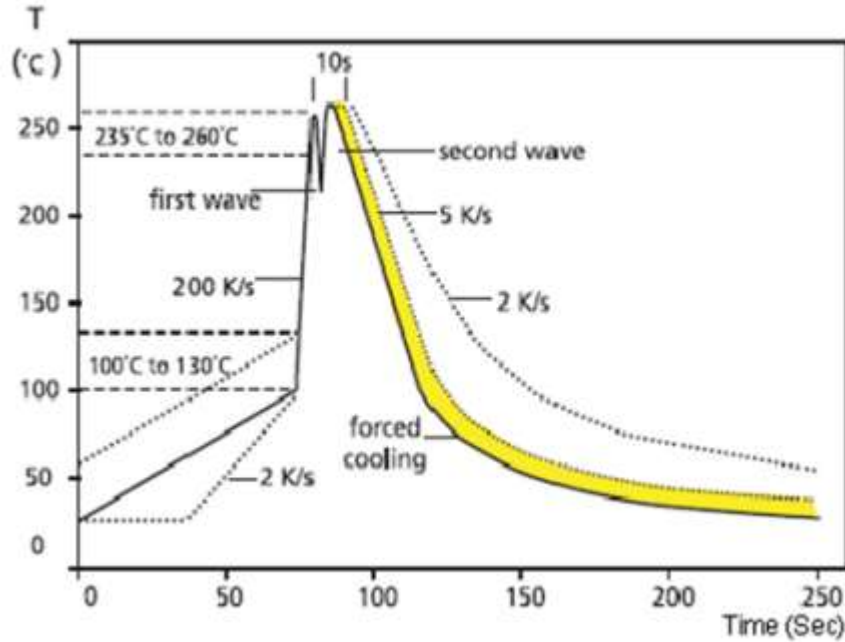

6.1.2 Lead Free IR Reflow Soldering Profile

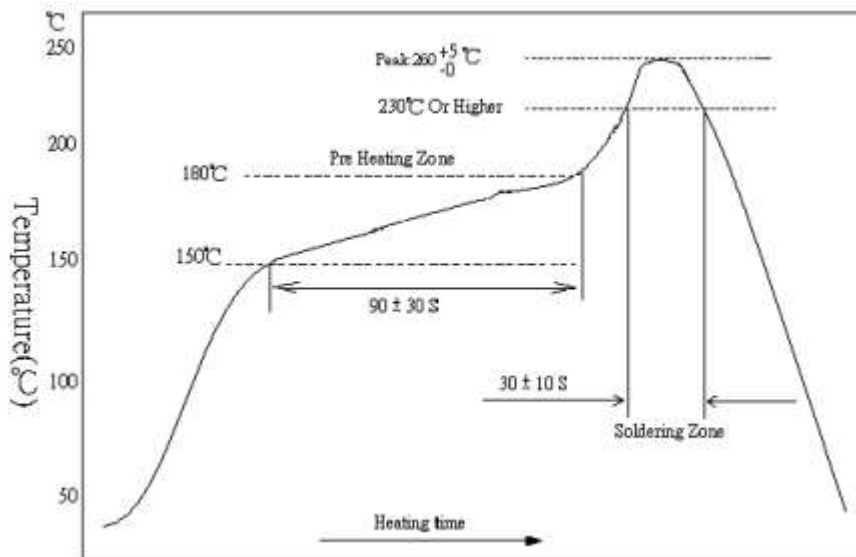

Remark: The peak temperature of soldering heat is $260 \pm 5^{\circ}\text{C}$ for 10 seconds.

6.1.3 Soldering Iron: Temperature $350^{\circ}\text{C} \pm 10^{\circ}\text{C}$, dwell time shall be less than 3 sec.

7. TAPING



7.1 Structure of Taping

Paper Carrier

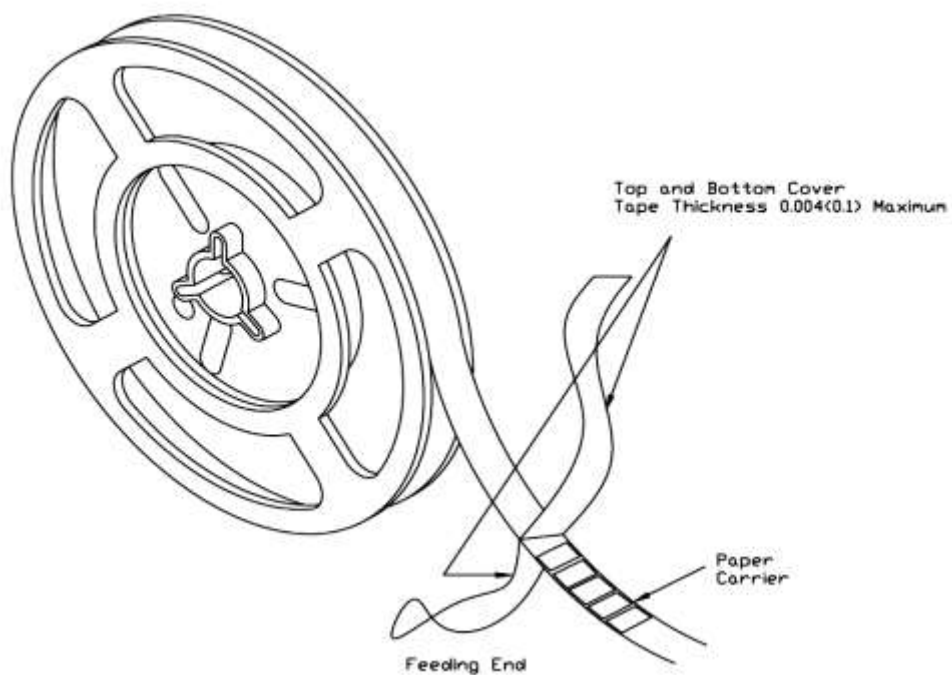

Embossed Plastic Carrier

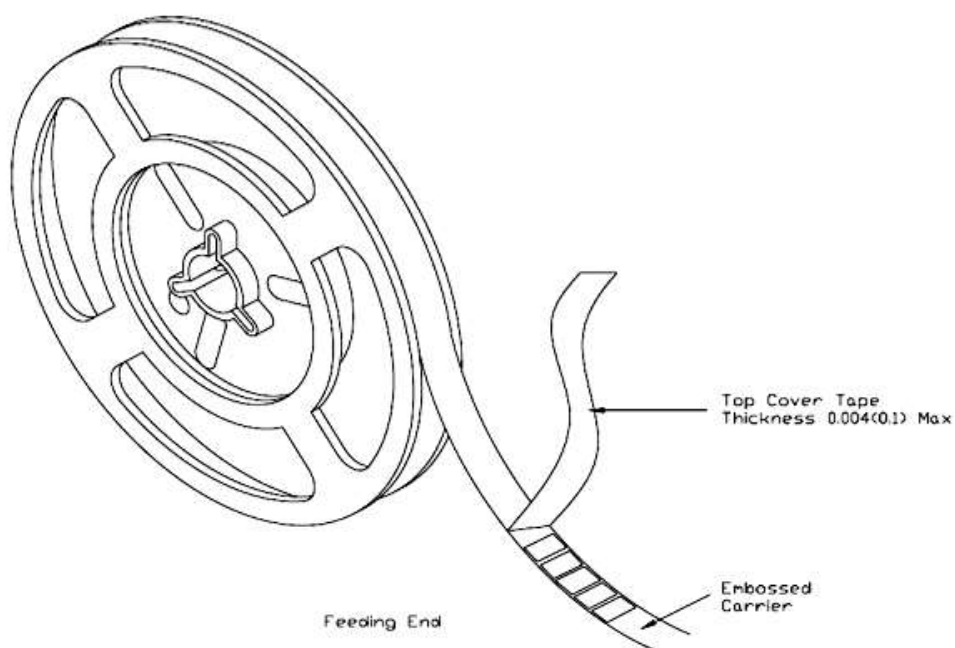

7.2 Dimension

THICK FILM CHIP RESISTORS AUTOMOTIVE GRADE

AR Series ($\geq 1\Omega$)

DS-ENG-021

Page: 12 of 17

7.2.1 Dimension of Punched Paper Tape Carrier System (AR05, 10)

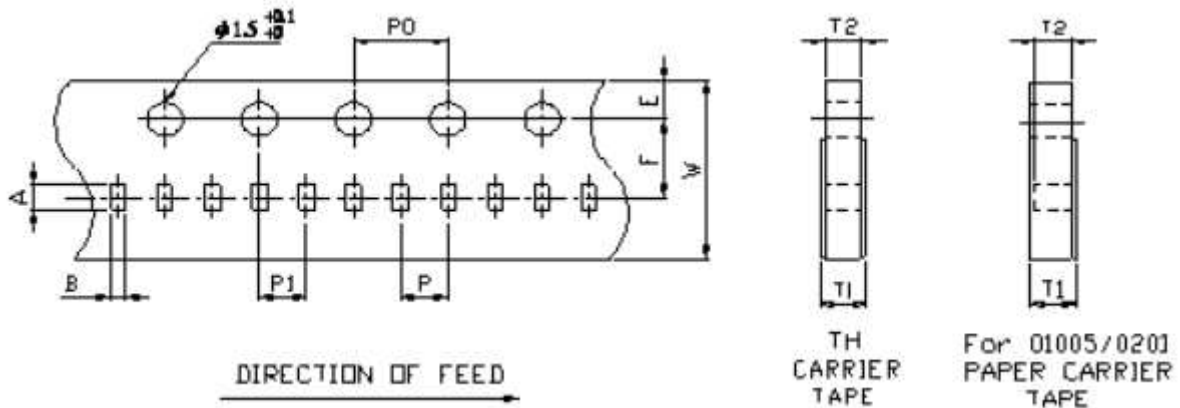

Remark: Pitch tolerance over any 10 pitches of P_0 is ± 0.2 mm

Dimension of Punched Paper Tape Carrier System (AR03, 05, 10) (unit : mm)

Code	A	B	W	E	F	T1
AR03	0.438 ± 0.03	0.23 ± 0.03	8.00 ± 0.30	1.75 ± 0.10	3.50 ± 0.05	0.31 ± 0.03

Code	T2	P	P0	10xP0	P1
AR03	0.17 ± 0.03	2.00 ± 0.05	4.00 ± 0.05	40.0 ± 0.20	2.00 ± 0.05

Code	A	B	W	E	F	T1
AR05	0.68 ± 0.05	0.38 ± 0.03	8.00 ± 0.10	1.75 ± 0.10	3.50 ± 0.05	$0.42^{+0.1}_{-0}$

Code	T2	P	P0	10xP0	P1
AR05	0.28 ± 0.02	2.00 ± 0.05	4.00 ± 0.05	40.0 ± 0.20	2.00 ± 0.05

Code	A	B	W	E	F	T1
AR10	1.15 ± 0.05	0.65 ± 0.05	8.00 ± 0.20	1.75 ± 0.10	3.50 ± 0.05	$0.42^{+0.2}_{-0}$

Code	T2	P	P0	10xP0	P1
AR10	0.40 ± 0.05	2.00 ± 0.10	4.00 ± 0.05	40.0 ± 0.20	2.00 ± 0.05

7.2.2 Dimension of Punched Paper Tape Carrier System /Plastic Embossed Carrier System



Product Specification

Towards Excellence in **Quality, Service & Innovation**

THICK FILM CHIP RESISTORS AUTOMOTIVE GRADE

AR Series ($\geq 1\Omega$)

DS-ENG-021

Page: 13 of 17

(AR16, 21, 32, 40)

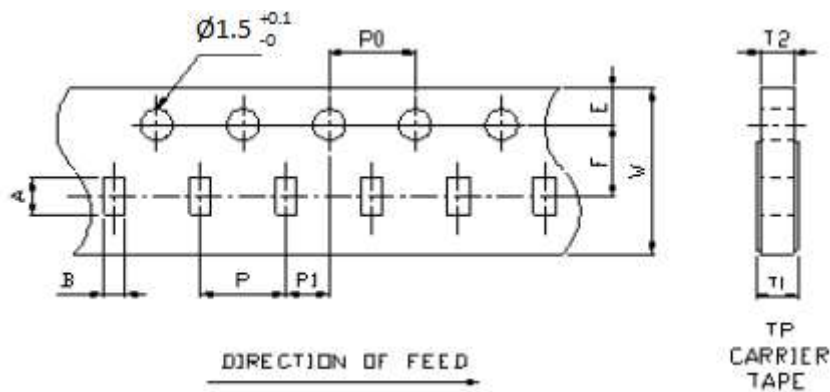

Remark : Pitch tolerance over any 10 pitches of P_0 is ± 0.2 mm

Dimension of Punched Paper Tape Carrier System (AR - 16, 21, 32, 40)

Code	A	B	W	E	F	T1	T2	P	P0	P1
AR16	1.8 ± 0.10	1.0 ± 0.10	8.0 ± 0.20	1.75 ± 0.10	3.50 ± 0.05	$0.60^{+0.2}_{-0}$	0.60 ± 0.10	4.0 ± 0.10	4.0 ± 0.05	2.0 ± 0.05
AR21	2.3 ± 0.10	1.55 ± 0.1	8.0 ± 0.20	1.75 ± 0.10	3.50 ± 0.05	$0.75^{+0.2}_{-0}$	0.75 ± 0.10	4.0 ± 0.10	4.0 ± 0.05	2.0 ± 0.05
AR32	3.5 ± 0.20	1.9 ± 0.20	8.0 ± 0.20	1.75 ± 0.10	3.50 ± 0.05	$0.75^{+0.2}_{-0}$	0.75 ± 0.10	4.0 ± 0.10	4.0 ± 0.05	2.0 ± 0.05
AR40	3.5 ± 0.20	2.8 ± 0.20	8.0 ± 0.20	1.75 ± 0.10	3.50 ± 0.05	$0.75^{+0.2}_{-0}$	0.75 ± 0.10	4.0 ± 0.10	4.0 ± 0.05	2.0 ± 0.05

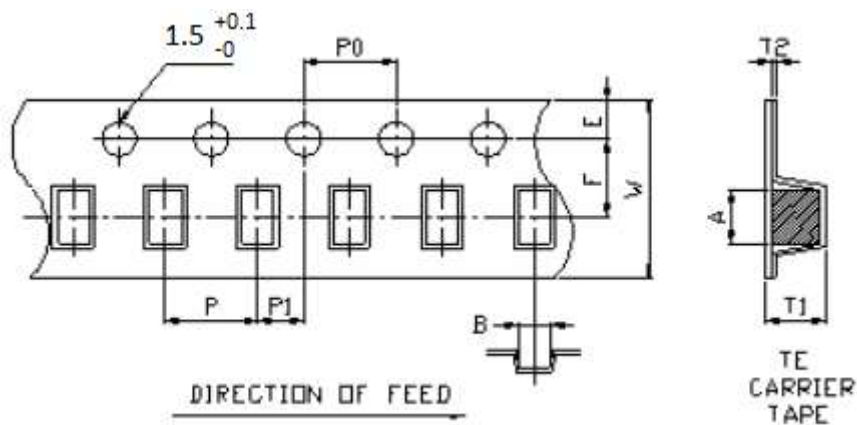

Dimension of Plastic Embossed Carrier System (AR - 50, 63)

Code	A	B	W	E	F	T1	T2	P	P0	P1
AR50	5.5 ± 0.20	2.8 ± 0.20	12.0 ± 0.20	1.75 ± 0.10	5.50 ± 0.05	1.10 ± 0.15	0.23 ± 0.15	4.0 ± 0.10	4.0 ± 0.05	2.0 ± 0.05
AR63	6.7 ± 0.20	3.4 ± 0.20	12.0 ± 0.20	1.75 ± 0.10	5.50 ± 0.05	1.10 ± 0.15	0.23 ± 0.15	4.0 ± 0.10	4.0 ± 0.05	2.0 ± 0.05

7.3 Packaging



Product Specification

Towards Excellence in Quality, Service & Innovation

7.3.1 Taping

7.3.1.1 Quantity – Tape and Reels

Code	Quantity	Model	Remarks
AR03	20000 pcs	7" Reel	2mm pitch
AR05 AR10	10000 pcs	7" Reel	2mm pitch
	20000 pcs	7" Reel	2mm pitch
	50000 pcs	13" Reel	2mm pitch
AR16	5000 pcs	7" Reel	4mm pitch
AR21	10000 pcs	10" Reel	4mm pitch
AR32 AR40	20000 pcs	13" Reel	4mm pitch
AR50 AR63	4000 pcs	7" Reel	4mm pitch

7.3.2 Identification

Production label that indicates the 8 digits lot number, product type, resistance value and tolerance shall be pasted on the surface of each reel.

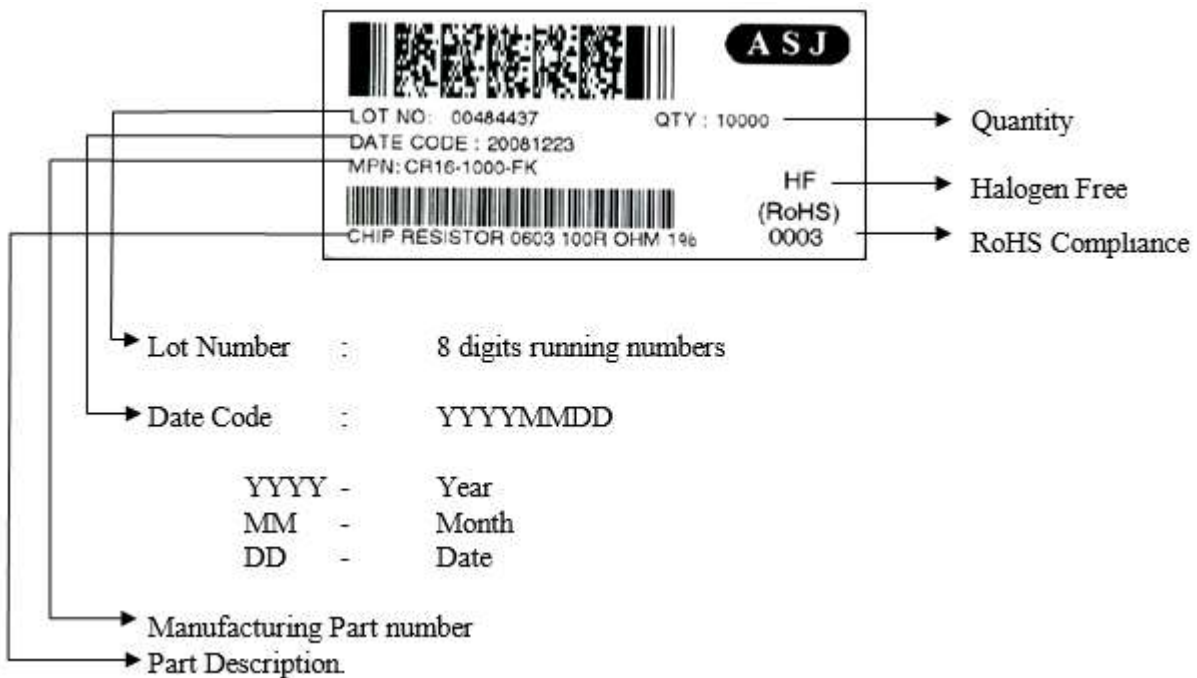

7.3.3 Packaging Reel Box

Dimension	Reel Box	Number of Reels
185 × 60 × 186 mm	25K Box	5
185 × 120 × 186 mm	50K Box	10

7.3.4 Reel Dimensions



THICK FILM CHIP RESISTORS AUTOMOTIVE GRADE

AR Series ($\geq 1\Omega$)

DS-ENG-021

Page: 15 of 17

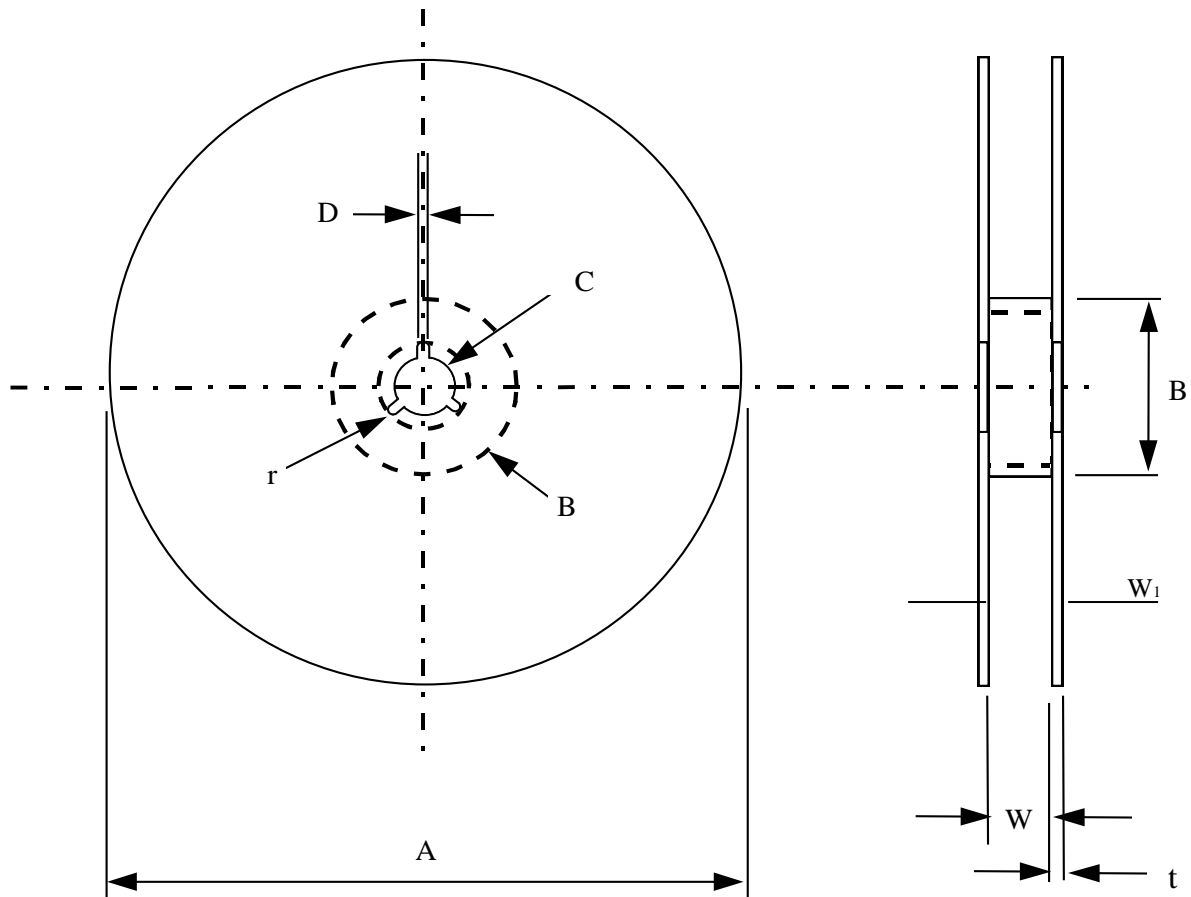

Model	A	B	C	D	W	W ₁	t	r
7" Reel (5K) (except 0402 10K)	$\phi 178 \pm 2.0$	$\phi 60 \text{min}$	13 ± 0.2	$\phi 2.0 \pm 0.5$	11 ± 0.1	14.4 max	1.0 ± 0.1	1.0
7" Reel (4K)	$\phi 178 \pm 2.0$	$\phi 60 \text{min}$	13 ± 0.2	$\phi 2.0 \pm 0.5$	13 ± 1.0	14.4 max	1.2 ± 0.1	1.0
7" Reel (10K)	$\phi 178 \pm 2.0$	$\phi 60 \text{min}$	13 ± 0.2	$\phi 2.0 \pm 0.5$	11 ± 0.1	14.4 max	1.0 ± 0.1	1.0
10" Reel (10K)	$\phi 254 \pm 2.0$	$\phi 60 \text{min}$	13 ± 0.2	$\phi 2.0 \pm 0.5$	11 ± 1.0	14.4 max	1.5 ± 0.1	1.0
13" Reel (20K, 50K)	$\phi 330 \pm 2.0$	$\phi 60 \text{min}$	13 ± 0.2	$\phi 2.0 \pm 0.5$	11 ± 1.0	14.4 max	2.1 ± 0.1	-
13" Reel (20K, 50K)	$\phi 330 \pm 1.0$	$\phi 100 \pm 1$	13.5 ± 0.5	$2 \sim 3 \pm 0.5$	10 ± 0.5	-	-	-

8. SURFACE MOUNT LAND PATTERNS DESIGN (FOR REFLOW SOLDERING)



Product Specification

Towards Excellence in **Quality, Service & Innovation**

THICK FILM CHIP RESISTORS AUTOMOTIVE GRADE

AR Series ($\geq 1\Omega$)

DS-ENG-021

Page: 16 of 17

When a component is soldered, the resistance after soldering changes slightly depending on the size of the soldering area and the amount of soldering. When designing a circuit, it is necessary to consider the effect of a decrease or increase in its resistance.

Unit:mm

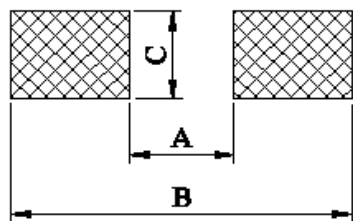

DIM TYPE	A	B	C
AR03	0.2	0.5	0.2
AR05	0.3	1.0	0.4
AR10	0.5	1.5	0.6
AR16	0.8	2.1	0.9
AR21	1.2	3.0	1.3
AR32	2.2	4.2	1.6
AR40	2.2	4.2	2.8
AR50	3.5	6.1	2.8
AR63	3.8	8.0	3.5

9. MEASUREMENT POINT

Bottom electrode	Unit : mm		
	DIM		
	TYPE	A	B
	AR03	0.44±0.05	0.22±0.05
	AR05	0.44±0.05	0.22±0.05
	AR10	0.80±0.05	0.24±0.05
	AR16	1.35±0.05	0.35±0.05
	AR21	1.80±0.05	0.35±0.05
	AR32	2.90±0.05	0.35±0.05
	AR40	2.90±0.05	0.35±0.05
	AR50	4.50±0.05	1.15±0.05
	AR63	5.90±0.05	1.60±0.05

10. REVISION HISTORY



Product Specification

Towards Excellence in **Quality, Service & Innovation**

THICK FILM CHIP RESISTORS AUTOMOTIVE GRADE

AR Series ($\geq 1\Omega$)

DS-ENG-021

Page: 17 of 17

REVISION	DATE	CHANGE NOTIFICATION	DESCRIPTION
Version.1	09.08.2016		Initial Release
Version.2	05.10.2016	Refer to PCN-ECO: 01/2016	Update 13' reel information into clause 7.3.5 table
Version.3	09.11.2018		1·Update clause 1 2·Update clause 2, Part Numbering System 3·Update clause 3.1.1, Resistor Rated Power 4·Update clause 3.2, Power Derating Characteristics. 5·Update clause 3.4, operating Temperature Range. 6·Update clause 3.10 information 7·Update clause 4, Marking on Product 8·Update clause 5, 5.1 & 5.2 9·Update clause 6 information 10·Update clause 6, Soldering Profile. 11·Update clause 7.2.1, AR05 carrier tape dimension. 12·Update clause 7.3.2, Tape and Reel quantity. 13·Update clause 8, AR05 Land Pattern dimension.
Version.4	19.02.2019		Update datasheet
Version.5	09.08.2019		Update clause 2 part numbering table
Version.6	28.09.2020		Add product AR03 into the spec Revise clause 2 Part numbering system Revise clause 3.1.1 Resistor rated power Revise clause 3.2 Power derating characteristic Revise clause 3.4 Operating Temp.range Revise clause 3.5 Revise clause 3.10 TCR table Revise clause 4 Marking on product Revise clause 5.1 dimension Revise clause 6 reliability test Revise clause 7.2.1 tape dimension Revise clause 7.3.2 tape and reel qty Revise clause 8 Land pattern dimension Revise clause 9 Measurement point dimension
Version.7	09.02.2021		Revise clause 1.3
Version.8	16.11.2021		Revise clause 2 Part numbering system Revise clause 4 Marking on product Revise clause 6 reliability test item Temperature cycling.
Version.9	30.03.2023		Revise clause 3.10 TCR table jumper resistance value
Version.10	21.08.2023		Revise clause 3.8 Product Assurance Revise clause 3.10 table Add clause 6 Item Sulfuration Test Revise clause 6 Item Temperature Cycling Revise clause 6 Item Humidity Bias Revise clause 6 Item High Temperature Operating Life Revise clause 6 Item Resistance to Soldering Heat Revise clause 6 Item Solderability



Product Specification

Towards Excellence in **Quality, Service & Innovation**