

To our customers,

Old Company Name in Catalogs and Other Documents

On April 1st, 2010, NEC Electronics Corporation merged with Renesas Technology Corporation, and Renesas Electronics Corporation took over all the business of both companies. Therefore, although the old company name remains in this document, it is a valid Renesas Electronics document. We appreciate your understanding.

Renesas Electronics website: <http://www.renesas.com>

April 1st, 2010
Renesas Electronics Corporation

Issued by: Renesas Electronics Corporation (<http://www.renesas.com>)

Send any inquiries to <http://www.renesas.com/inquiry>.

Notice

1. All information included in this document is current as of the date this document is issued. Such information, however, is subject to change without any prior notice. Before purchasing or using any Renesas Electronics products listed herein, please confirm the latest product information with a Renesas Electronics sales office. Also, please pay regular and careful attention to additional and different information to be disclosed by Renesas Electronics such as that disclosed through our website.
2. Renesas Electronics does not assume any liability for infringement of patents, copyrights, or other intellectual property rights of third parties by or arising from the use of Renesas Electronics products or technical information described in this document. No license, express, implied or otherwise, is granted hereby under any patents, copyrights or other intellectual property rights of Renesas Electronics or others.
3. You should not alter, modify, copy, or otherwise misappropriate any Renesas Electronics product, whether in whole or in part.
4. Descriptions of circuits, software and other related information in this document are provided only to illustrate the operation of semiconductor products and application examples. You are fully responsible for the incorporation of these circuits, software, and information in the design of your equipment. Renesas Electronics assumes no responsibility for any losses incurred by you or third parties arising from the use of these circuits, software, or information.
5. When exporting the products or technology described in this document, you should comply with the applicable export control laws and regulations and follow the procedures required by such laws and regulations. You should not use Renesas Electronics products or the technology described in this document for any purpose relating to military applications or use by the military, including but not limited to the development of weapons of mass destruction. Renesas Electronics products and technology may not be used for or incorporated into any products or systems whose manufacture, use, or sale is prohibited under any applicable domestic or foreign laws or regulations.
6. Renesas Electronics has used reasonable care in preparing the information included in this document, but Renesas Electronics does not warrant that such information is error free. Renesas Electronics assumes no liability whatsoever for any damages incurred by you resulting from errors in or omissions from the information included herein.
7. Renesas Electronics products are classified according to the following three quality grades: “Standard”, “High Quality”, and “Specific”. The recommended applications for each Renesas Electronics product depends on the product’s quality grade, as indicated below. You must check the quality grade of each Renesas Electronics product before using it in a particular application. You may not use any Renesas Electronics product for any application categorized as “Specific” without the prior written consent of Renesas Electronics. Further, you may not use any Renesas Electronics product for any application for which it is not intended without the prior written consent of Renesas Electronics. Renesas Electronics shall not be in any way liable for any damages or losses incurred by you or third parties arising from the use of any Renesas Electronics product for an application categorized as “Specific” or for which the product is not intended where you have failed to obtain the prior written consent of Renesas Electronics. The quality grade of each Renesas Electronics product is “Standard” unless otherwise expressly specified in a Renesas Electronics data sheets or data books, etc.
 - “Standard”: Computers; office equipment; communications equipment; test and measurement equipment; audio and visual equipment; home electronic appliances; machine tools; personal electronic equipment; and industrial robots.
 - “High Quality”: Transportation equipment (automobiles, trains, ships, etc.); traffic control systems; anti-disaster systems; anti-crime systems; safety equipment; and medical equipment not specifically designed for life support.
 - “Specific”: Aircraft; aerospace equipment; submersible repeaters; nuclear reactor control systems; medical equipment or systems for life support (e.g. artificial life support devices or systems), surgical implantations, or healthcare intervention (e.g. excision, etc.), and any other applications or purposes that pose a direct threat to human life.
8. You should use the Renesas Electronics products described in this document within the range specified by Renesas Electronics, especially with respect to the maximum rating, operating supply voltage range, movement power voltage range, heat radiation characteristics, installation and other product characteristics. Renesas Electronics shall have no liability for malfunctions or damages arising out of the use of Renesas Electronics products beyond such specified ranges.
9. Although Renesas Electronics endeavors to improve the quality and reliability of its products, semiconductor products have specific characteristics such as the occurrence of failure at a certain rate and malfunctions under certain use conditions. Further, Renesas Electronics products are not subject to radiation resistance design. Please be sure to implement safety measures to guard them against the possibility of physical injury, and injury or damage caused by fire in the event of the failure of a Renesas Electronics product, such as safety design for hardware and software including but not limited to redundancy, fire control and malfunction prevention, appropriate treatment for aging degradation or any other appropriate measures. Because the evaluation of microcomputer software alone is very difficult, please evaluate the safety of the final products or system manufactured by you.
10. Please contact a Renesas Electronics sales office for details as to environmental matters such as the environmental compatibility of each Renesas Electronics product. Please use Renesas Electronics products in compliance with all applicable laws and regulations that regulate the inclusion or use of controlled substances, including without limitation, the EU RoHS Directive. Renesas Electronics assumes no liability for damages or losses occurring as a result of your noncompliance with applicable laws and regulations.
11. This document may not be reproduced or duplicated, in any form, in whole or in part, without prior written consent of Renesas Electronics.
12. Please contact a Renesas Electronics sales office if you have any questions regarding the information contained in this document or Renesas Electronics products, or if you have any other inquiries.

(Note 1) “Renesas Electronics” as used in this document means Renesas Electronics Corporation and also includes its majority-owned subsidiaries.

(Note 2) “Renesas Electronics product(s)” means any product developed or manufactured by or for Renesas Electronics.

To all our customers

Regarding the change of names mentioned in the document, such as Mitsubishi Electric and Mitsubishi XX, to Renesas Technology Corp.

The semiconductor operations of Hitachi and Mitsubishi Electric were transferred to Renesas Technology Corporation on April 1st 2003. These operations include microcomputer, logic, analog and discrete devices, and memory chips other than DRAMs (flash memory, SRAMs etc.) Accordingly, although Mitsubishi Electric, Mitsubishi Electric Corporation, Mitsubishi Semiconductors, and other Mitsubishi brand names are mentioned in the document, these names have in fact all been changed to Renesas Technology Corp. Thank you for your understanding. Except for our corporate trademark, logo and corporate statement, no changes whatsoever have been made to the contents of the document, and these changes do not constitute any alteration to the contents of the document itself.

Note : Mitsubishi Electric will continue the business operations of high frequency & optical devices and power devices.

Renesas Technology Corp.
Customer Support Dept.
April 1, 2003

M51362SP

PLL-SPLIT VIF/SIF

DESCRIPTION

The M51362SP is a semiconductor IC consisting of IF signal processor suitable for color TV sets and VCRs with AV which is a revision of M51365SP.

The circuit includes VIF amplifier, Video detector, VCO, APC detector, AFT, video equalizer, IF/RF AGC, SIF detector, SIF limiter, FM detector functions.

FEATURES

- A full synchronous detector circuit using PLL as video detector provides excellent DG, DP, 920kHz beat and cross color characteristics.
- The PLL-SPLIT method in which video IF and audio IF signal processings are separated and VCO output is used to obtain intercarrier provides good sound sensitivity and reduces buzz. In consumer sets, intercarrier is also available from the video detector output.
- Built-in video equalizer is suitable for VCRs and color TV sets equipped with video output terminals.
- The quadrature detector circuit for FM detector has good linearity with a simple coil.
- The M51362SP has better video S/N ratio than M51365SP by 2~4dB.

APPLICATIONS

TV sets, VCR tuners

RECOMMENDED OPERATING CONDITIONS

Supply voltage range8~10V

Rated supply voltage9V

PIN CONFIGURATION (TOP VIEW)

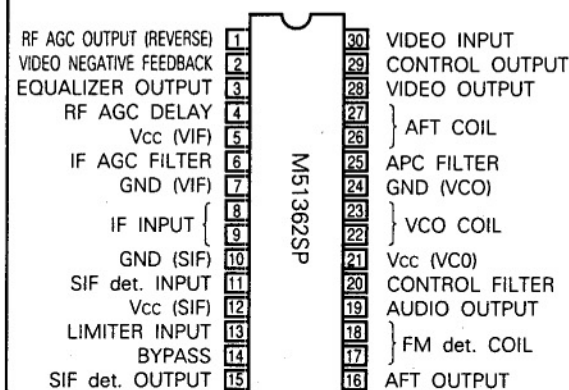

Outline 30P4B

BLOCK DIAGRAM

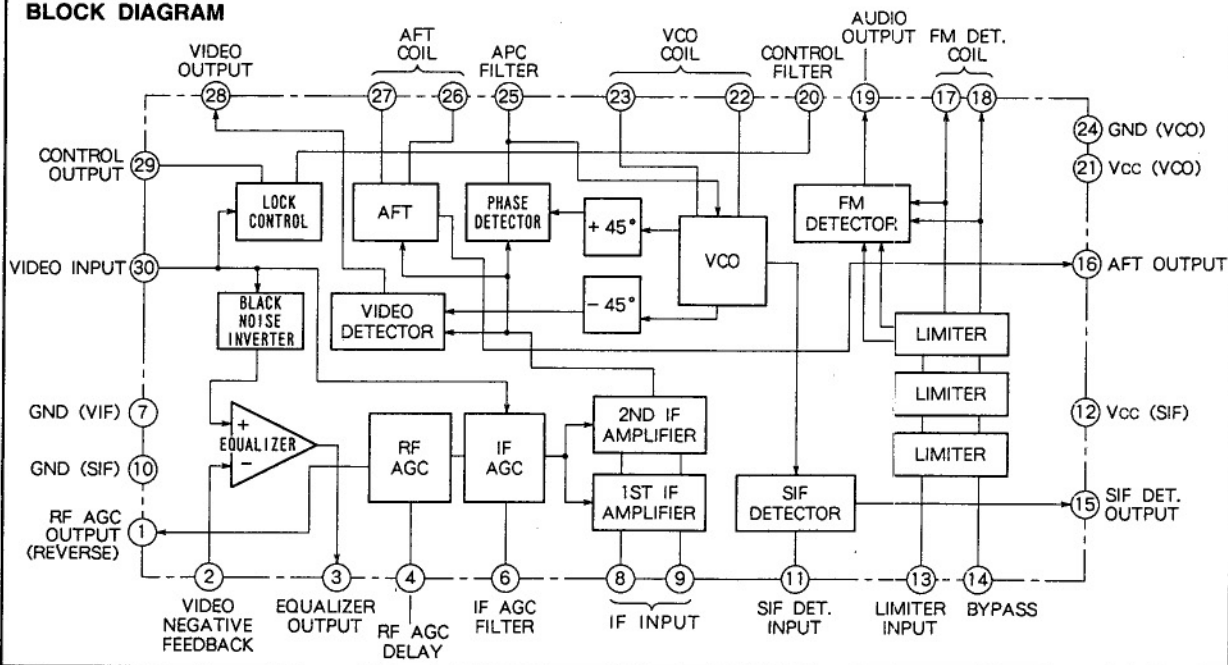

M51362SP

PLL-SPLIT VIF/SIF

ABSOLUTE MAXIMUM RATINGS

Symbol	Parameter	Ratings	Unit
V _{cc}	Supply voltage	14	V
P _d	Power dissipation	1250	mW
T _{opr}	Operating temperature	-20~75	°C
T _{stg}	Storage temperature	-40~125	°C

ELECTRICAL CHARACTERISTICS (T_a = 25°C, V_{cc} = 9V unless otherwise noted)

VIF SECTION

Symbol	Parameter	Test circuit	Test point	Test conditions						Limits			Unit
				Input signal		External power supply (V)			* Switches should usually be set to 1.	Min.	Typ.	Max.	
VIF	SIF1	V ₁	V ₆	V ₂₀									
I _{cc} (VIF)	Circuit current (VIF)	1	A1	-	-	3	-	-	SW1 = 2	33	45	57	mA
V ₂₈	Video detector output DC voltage 1	1	TP9	-	-	3	0	-	SW3 = 2	3.4	3.75	4.1	V
V ₃	Video detector output DC voltage 2	1	TP2	-	-	3	0	-	SW3 = 2	4.4	4.8	5.2	V
V _{o det1}	Video detector output 1	1	TP9	SG1	-	3	-	-		1.15	1.45	1.75	V _{P-P}
V _{o det2}	Video detector output 2	1	TP2	SG1	-	3	-	-		1.6	1.95	2.3	V _{P-P}
P/N	Video S/N	1	TP10	SG6	-	3	-	-	SW6 = 2 (note 1)	44	52		dB
Bw	Video frequency characteristics	1	TP9	SG3	-	3	-	-	(note 2)	5.5	7.5		MHz
V _{in} (min)	Input sensitivity	1	TP9	SG4	-	3	-	-	(note 3)		46	51	dB μ
V _{in} (max)	Maximum allowable input	1	TP9	SG5	-	3	-	-	(note 4)	107	110		dB μ
GR	AGC control range	1	-	-	-	-	-	-	(note 5)	58	64		dB
V _{IH}	IF AGC maximum voltage	1	TP3	-	-	3	-	-		6.5	8.6		V
V _I (80dBμ)	IF AGC (80dB μ)	1	TP3	SG6	-	3	-	-		4.3	4.9	5.5	V
V _{IL}	IF AGC minimum voltage	1	TP3	SG7	-	3	-	-		3.4	3.9	4.4	V
V _{o SIF-1}	SIF det. 4.5MHz output(100dB μ)	1	TP4	SG2	SG8	3	-	-		104	109	114	dB μ
V _{o SIF-2}	SIF det. 4.5MHz output(80dB μ)	1	TP4	SG2	SG9	3	-	-		90	96	101	dB μ
V _{I6}	AFT output voltage	1	TP5	-	-	3	0	-		3.2	4.3	5.4	V
μ	AFT detector sensitivity	1	TP5	SG10	-	3	-	-	(note 6)	48	70	92	mV/kHz
V _{I6H}	AFT maximum voltage	1	TP5	SG10	-	3	-	-	(note 7)	8	8.7		V
V _{I6L}	AFT minimum voltage	1	TP5	SG10	-	3	-	-	(note 8)		0.38	1.0	V
V _{IH}	RF AGC maximum voltage	1	TP1	SG2	-	2	-	-		7	7.85		V
V _{IL}	RF AGC minimum voltage	1	TP1	SG2	-	4	-	-			0	1.0	V
CL-U1	Capture range (U)	1	TP9	SG11	-	3	-	-	(note 9)	0.45	0.8		MHz
CL-L1	Capture range (L)	1	TP9	SG11	-	3	-	-	(note 10)	1.4	2.0		MHz
CL-T	Capture range (T)	1	-	-	-	-	-	-	(note 11)	2.0	2.8		MHz
CL-U2	Capture range (U)	1	TP9	SG11	-	3	-	-	SW5 = 2 (note 9)	0.45	0.8	1.2	MHz
CL-L2	Capture range (L)	1	TP9	SG11	-	3	-	-	SW5 = 2 (note 10)	1.0	1.6	2.2	MHz
V _{20TH}	Lock detector threshold voltage	1	TP8	-	-	3	5	Variable	SW3,4,5 = 2 (note 12)	3.6	4.0	4.4	V
V _{29L}	Minimum voltage at pin ②	1	TP8	-	-	3	5	Variable	SW3,4,5 = 2 (note 13)		0.05	0.5	V
FC1	EQ frequency characteristics 1	1	TP9 TP2	SG12	-	3	-	-	Refer to (note 14)	1.4	2.4	3.4	dB
FC2	EQ frequency characteristics 2	1	TP9 TP2	SG13	-	3	-	-	Refer to (note 14)	4.2	5.7	7.2	dB
FC3	EQ frequency characteristics 3	1	TP9 TP2	SG14	-	3	-	-	Refer to (note 14)	9.5	12.0	14.5	dB
IM	Intermodulation	1	TP9	SG15	-	3	Variable	-	SW3 = 2 (note 15)	34	39		dB
DG	DG	1	TP9	SG16	-	3	-	-	(note 16)		2	5	%
DP	DP	1	TP9	SG16	-	3	-	-	(note 16)		2	5	deg.

M51362SP

PLL-SPLIT VIF/SIF

VIF SECTION (cont.)

Symbol	Parameter	Test circuit	Test point	Test conditions						Limits			Unit
				Input signal		External power supply (V)			* Switches should usually be set to 1.	Min.	Typ.	Max.	
				VIF	SIF1	V ₁	V ₆	V ₂₀					
V _{BTH}	Black spot inverter threshold level	1	TP2	SG1	-	3	Variable	-	SW3 = 2 (note 17)	1.3	1.7	2.1	V
V _{BCL}	Black spot inverter clamp level	1	TP2	SG1	-	3	Variable	-	SW3 = 2 (note 17)	3.7	4.2	4.7	V
V _{SYNC}	Sync tip level at pin ③	1	TP2	SG2	-	3	-	-		2.1	2.5	2.9	V
R _{in} (V)	VIF input resistance	2		90dB μ	-	3	-	-			0.9		k Ω
C _{in} (V)	VIF input capacitance	2		90dB μ	-	3	-	-			6.6		pF
R _{in} (S1)	SIF1 input resistance	2		-	90dB μ	3	-	-			2.1		k Ω
C _{in} (S1)	SIF1 input capacitance	2		-	90dB μ	3	-	-			2.5		pF

SIF SECTION

Symbol	Parameter	Test circuit	Test point	Test conditions						Limits			Unit
				Input signal		External power supply (V)			* Switches should usually be set to 1.	Min.	Typ.	Max.	
				SIF2		V ₁	V ₆	V ₂₀					
I _{cc} (SIF)	Circuit current (SIF)	1	A2	-		0	-	-	SW2 = 2	6.1	8.7	11.4	mA
V ₁₉	AF output DC voltage	1	TP6	-		0	-	-		4.1	4.9	5.7	V
V _{OA} FMAX	Maximum AF output	1	TP6	SG17		0	-	-		225	300	375	mVrms
THDAF	AF output distortion	1	TP6	SG21		0	-	-			0.2	1.0	%
V _{in} (lim)	Input limiting sensitivity	1	TP6	SG18		0	-	-	(note 13)		34	42	dB μ
AMR	AMR	1	TP6	SG19		0	-	-	(note 13)	58	68		dB
S/N	AF S/N	1	TP6	SG20		0	-	-	(note 20)	58	73		dB

ELECTRICAL CHARACTERISTICS TEST METHOD

Note1. Video S/N "P/N"

- a. Input SG6 in VIF IN.
- b. The noise appearing at pin ② is determined by measuring the r.m.s. voltage at TP10 through low pass filter (-3dB at 5MHz).

$$c. P/N = 20 \log \left\{ \frac{\text{Vodet 1 (V}_{p-p}) \times 0.7}{\text{noise (Vrms)}} \right\}$$

where Vodet 1 denotes video detector output 1.

Note2. Video frequency characteristics "Bw"

- a. Set SG3 as follows:
 - f₁ = 58.75MHz V_i = 90dB μ
 - f₂ = 57.75MHz V_i = 70dB μ
 } mixed signal

- b. Measure the element of 1MHz at TP9 and the result is defined as V₁.
- c. Decrease the frequency until element (f₁-f₂) at TP9 reaches 3dB less than V₁. Then, read the frequency.
- d. Bw = 58.75 - f₂ (MHz)

Note3. Input sensitivity "Vin (min)"

- a. Input SG4 in VIF IN.
- b. Decrease the SG4 level and the level at which detector output at pin ② reaches 3dB less than Vodet 1 is defined as input sensitivity.

Note4. Maximum allowable input "Vin (max)"

- a. Set SG5 to 90dB μ and input it in VIF IN.
- b. Detector output at pin ② at this time is defined as V₂.
- c. Increase the voltage of SG5 and voltage at which detector output reaches 3dB less than V₂ is defined as maximum allowable input.

Note5 AGC control range "GR"

- a. AGC control range is defined as follows:
GR = Maximum allowable input - Input sensitivity

Note6 AFT detector sensitivity "μ"

- a. Input SG10 in VIF IN.
- b. Measure difference of frequency between 3.0V and 6.0V of DC voltage at TP5 and the difference is defined as Δf.
- c. AFT detector sensitivity μ is defined as follows:

$$\mu = \frac{3000\text{mV}}{\Delta f \text{ (kHz)}} \text{ (mV/kHz)}$$

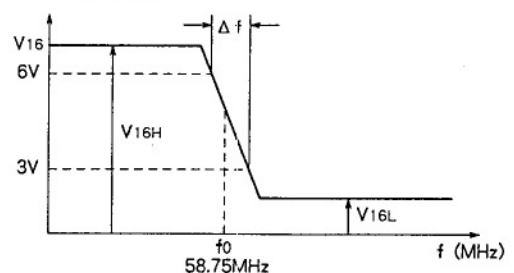

Note7. AFT maximum voltage "V_{16H}"

a. Maximum DC voltage in the figure on the previous page is defined as V_{16H}.

Note8. AFT minimum voltage "V_{16L}"

b. Minimum DC voltage in the figure on the previous page is defined as V_{16L}.

Note9. Capture range (U) "CL-U-1," "CL-U-2"

- a. Input SG11 in VIF IN and increase the frequency till VCO lock is released.
- b. Decrease the frequency of SG11 and the frequency at which VCO locks again is defined as f_v (MHz).
- c. Capture range (U) is defined as f_v - 58.75 (MHz).

Note10. Capture range (L) "CL-L-1," "CL-L-2"

- a. Input SG11 in VIF IN and decrease the frequency till VCO lock is released.
- b. Increase the frequency of SG11 and the frequency at which VCO locks again is defined as f_l (MHz).
- c. Capture range (L) is defined as 58.75 - f_l (MHz).

Note11. Capture range (T) "CT-T"

a. "CL-T" is defined as "CL-U-1" + "CL-L-1" (MHz).

Note12. Lock detector threshold voltage "V_{20TH}"

- a. Set the voltage at V₂₀ to 3V and observe TP8.
- b. Increase the voltage at V₂₀ and the point at which TP8 voltage changes drastically is defined as V_{20TH} (threshold 1V).

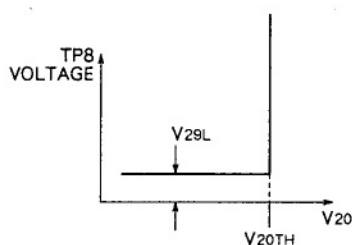

Note13. Minimum voltage at pin ② "V_{29L}"

a. Minimum voltage in Note12 is defined as V_{29L}.

Note14. EQ frequency characteristics "FC1" "FC2" "FC3"

- a. Input SG12, SG13 or SG14 to VIF IN.
- b. Measure the level of element (f₁-f₂) at TP9 and it is defined as V_{EQ IN} (dBμ).
- c. Measure the level of element (f₁-f₂) at TP2 and it is defined as V_{EQ OUT} (dBμ).
- d. EQ frequency characteristics is defined as follows:
FC1~3 = V_{EQ OUT} - V_{EQ IN} (dB)

Note15. Intermodulation "IM"

- a. Input SG15 in VIF IN.
- b. Observe TP9 with oscilloscope, and adjust the voltage of V₆ so that the minimum level of detector output waveform will come to 2V.

c. Observe TP9 with spectrum analyzer at this time, and the ratio of the 920kHz level to the 3.58MHz level is defined as intermodulation.

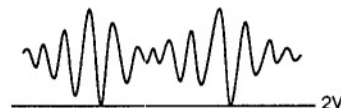

Note16. DG, DP "DG, DP"

- a. Modulated waves of SG16 is generated by 87.5% video modulation of the 10-step waves as shown in the figure below.
- b. Measure DG and DP at TP9 with vectorscope.

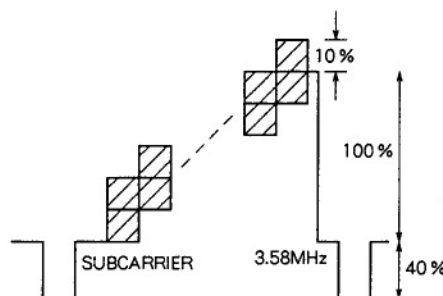

Note17. Black spot inverter threshold level, clamp level "V_{B TH}, V_{B CL}"

- a. Input SG1 in VIF IN.
- b. By varying V₆, output the waveform as shown in the figure below to TP2 and measure each DC voltage.

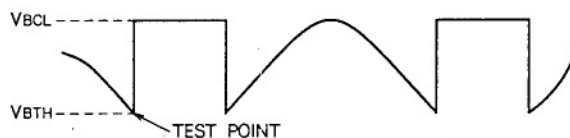

Note18 Input limiting sensitivity "V_{in (lim)}"

- a. Set SG18 to 80dBμ and input it in SIF2 IN.
- b. Decrease the output level of SG18 until detector output at TP6 becomes 3dB smaller than V_{o AF MAX}.
The level of SG18 at this time is input limiting sensitivity.

Note19. AMR "AMR"

- a. Input SG19 in SIF2 IN.
- b. Measure the output voltage at TP6 and it is defined as V_{AM}.
- c. AMR is defined as follows:

$$AMR = 20 \log \left\{ \frac{V_{O AF MAX} (mVrms)}{V_{AM} (mVrms)} \right\} (dB)$$

M51362SP

PLL-SPLIT VIF/SIF

Note20. AF S/N "S/N"

- Input SG20 in SIF2 IN.
- Measure the output voltage at TP6 and it is defined as V_N .
- AF S/N is defined as follows:

$$S/N = 20 \log \left\{ \frac{V_{O \text{ AF MAX}} (\text{mVrms})}{V_N (\text{mVrms})} \right\} (\text{dB})$$

- Amplitude level of all AM modulated waves are the peak level of modulated waves.
- The following is used for the mixer:

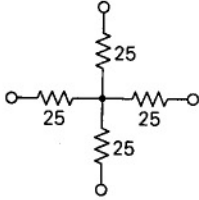

- With V_{CO} coil, IF AGC 0V and non-input condition, adjust free run frequency to 58.75MHz.

INPUT SIGNAL

SG No.	Signals (50 Ω termination)
SG1	$f_0=58.75\text{MHz}$ $V_i=90\text{dB}\mu$ 77.78%AM <small>(Corresponding to 87.5K video modulation $f_m=20\text{kHz}$)</small>
SG2	$f_0 = 58.75\text{MHz}$ $V_i = 90\text{dB}\mu$
SG3	$f_1 = 58.75\text{MHz}$ $V_i = 90\text{dB}\mu$ $f_2 = 53 \pm 5\text{MHz}$ $V_i = 70\text{dB}\mu$ } mixed signal
SG4	$f_0 = 58.75\text{MHz}$ $V_i = \text{Vvariable}$ $f_m = 20\text{kHz}$ 77.78% AM
SG5	$f_0 = 58.75\text{MHz}$ $V_i = \text{Vvariable}$ $f_m = 20\text{kHz}$ 16% AM
SG6	$f_0 = 58.75\text{MHz}$ $V_i = 80\text{dB}\mu$
SG7	$f_0 = 58.75\text{MHz}$ $V_i = 110\text{dB}\mu$
SG8	$f_0 = 54.25\text{MHz}$ $V_i = 100\text{dB}\mu$
SG9	$f_0 = 54.25\text{MHz}$ $V_i = 80\text{dB}\mu$
SG10	$f_0 = 58.75\text{MHz} \pm 5\text{MHz}$ $V_i = 90\text{dB}\mu$
SG11	$f_0=58.75\text{MHz} \pm 5\text{MHz}$ $V_i=90\text{dB}\mu$ $f_m=20\text{kHz}$ 77.78%AM
SG12	$f_1 = 58.75\text{MHz}$ $V_i = 90\text{dB}\mu$ $f_2 = 58.25\text{MHz}$ $V_i = 60\text{dB}\mu$ } mixed signal
SG13	$f_1 = 58.75\text{MHz}$ $V_i = 90\text{dB}\mu$ $f_2 = 55.75\text{MHz}$ $V_i = 60\text{dB}\mu$ } mixed signal
SG14	$f_1 = 58.75\text{MHz}$ $V_i = 90\text{dB}\mu$ $f_2 = 54.75\text{MHz}$ $V_i = 60\text{dB}\mu$ } mixed signal
SG15	$f_1 = 58.75\text{MHz}$ $V_i = 90\text{dB}\mu$ $f_2 = 55.17\text{MHz}$ $V_i = 80\text{dB}\mu$ $f_3 = 54.25\text{MHz}$ $V_i = 80\text{dB}\mu$ } mixed signal
SG16	$f_0 = 58.75\text{MHz}$ standard 10 - step modulation $m = 87.5\%$ video modulation, sync tip level 90dB μ
SG17	$f_0 = 4.5\text{MHz} \pm 25\text{kHz}$ dev $V_i = 100\text{dB}\mu$ $f_m = 400\text{Hz}$
SG18	$f_0 = 4.5\text{MHz} \pm 25\text{kHz}$ dev $V_i = \text{Vvariable}$ $f_m = 400\text{Hz}$
SG19	$f_0 = 4.5\text{MHz}$ $V_i = 100\text{dB}\mu$ 30% AM $f_m = 400\text{Hz}$
SG20	$f_0 = 4.5\text{MHz}$ $V_i = 100\text{dB}\mu$
SG21	$f_0 = 4.5\text{MHz}$ $V_i = 100\text{dB}\mu$ $f_m = 400\text{Hz} \pm 7.5\text{kHz}$ dev

M51362SP

PLL-SPLIT VIF/SIF

TEST CIRCUIT 1

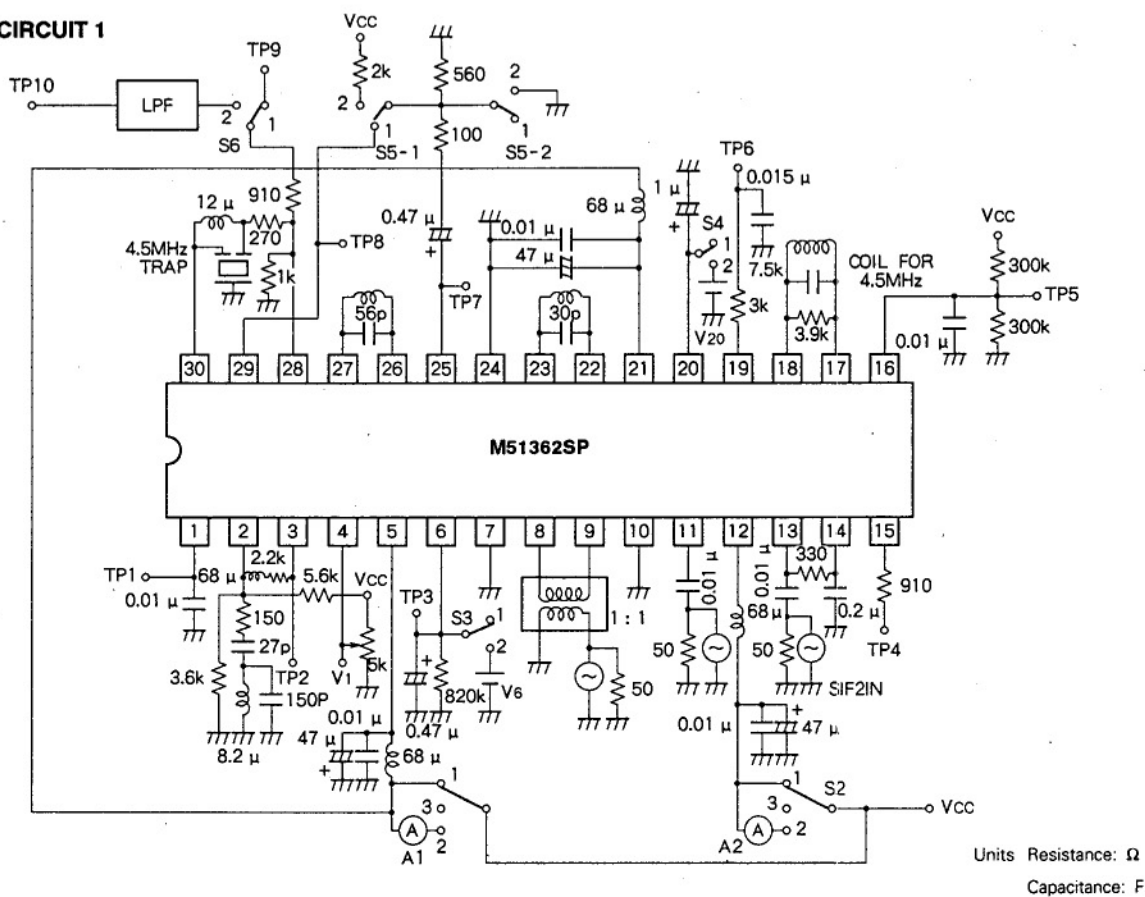

TEST CIRCUIT 2

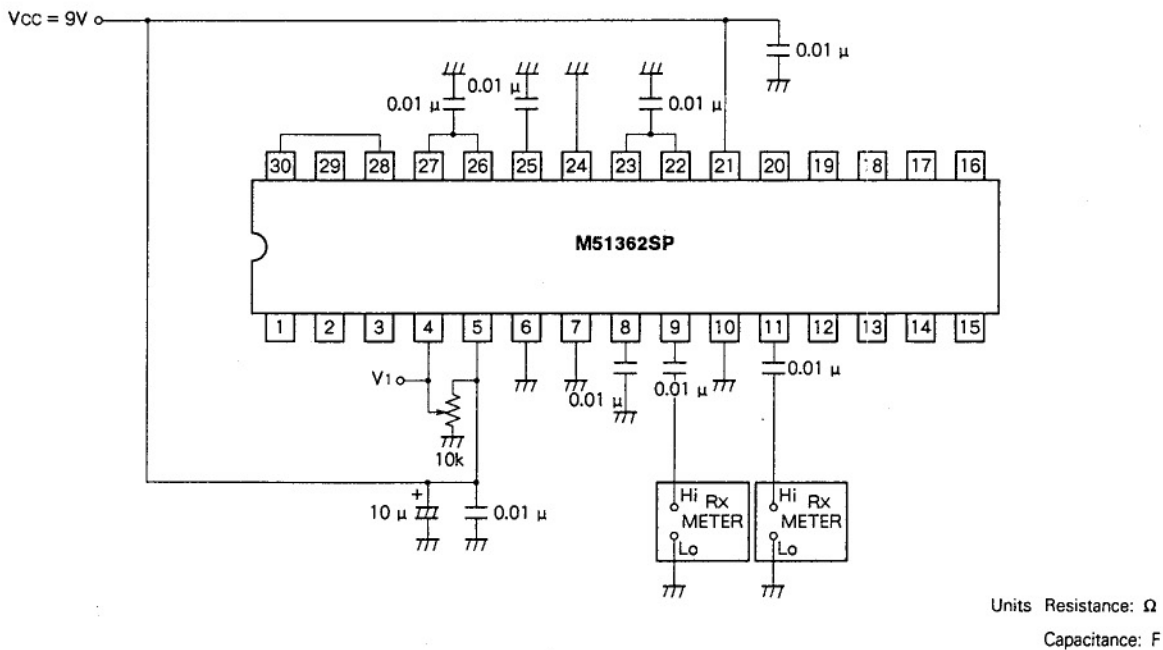

TYPICAL CHARACTERISTICS

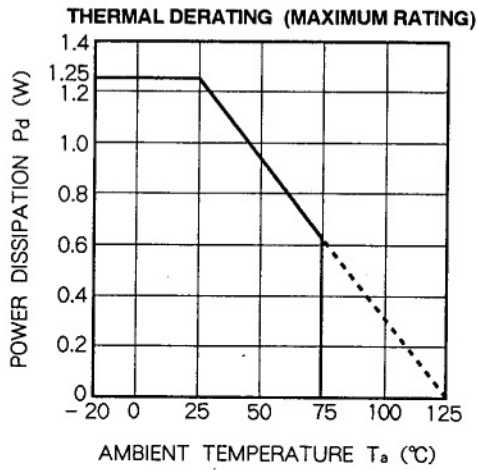

APPLICATION EXAMPLE

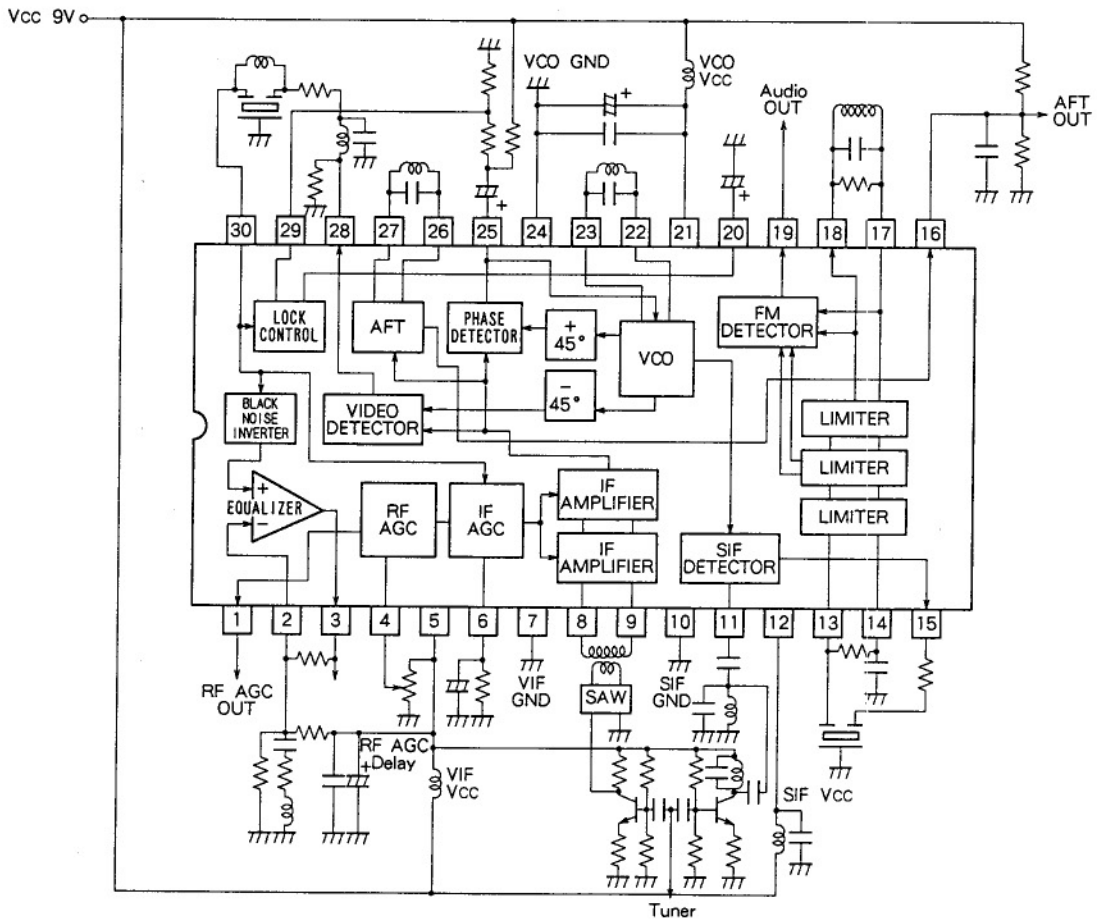

Units Resistance: Ω
Capacitance: F

DESCRIPTION OF PIN

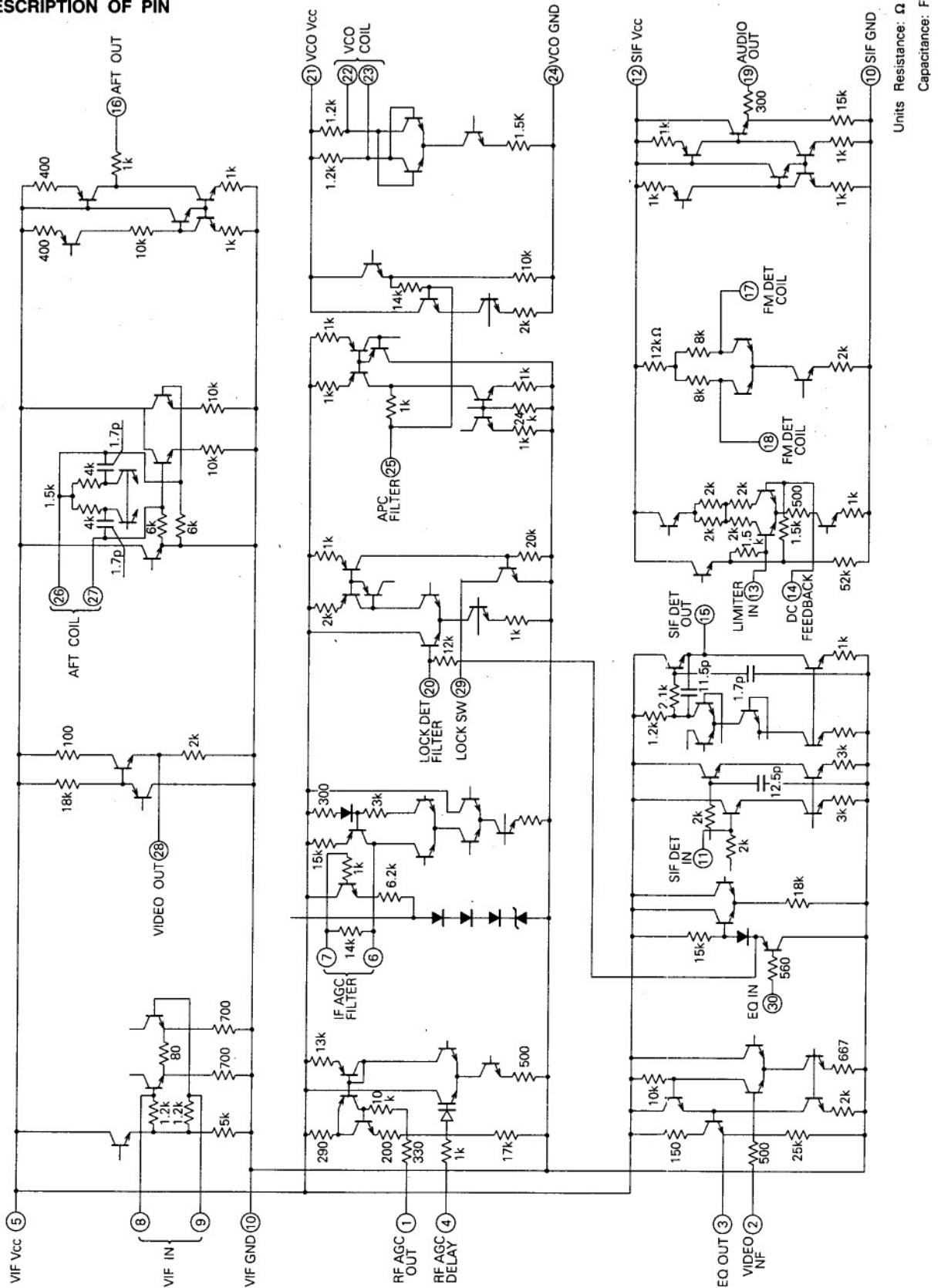

PRECAUTIONS FOR APPLICATION

1. VIF Amplifier

The VIF amplifier is a two-stage amplifier without DC feedback.

With a gain of approx. 40dB, the VIF amplifier is connected to a video detector via an internal capacitor.

Maximum input amplitude is determined by the input dynamic range of the VIF amplifier, allowing up to 110dB μ input. During excessive input, surpassing this limit will cause the linearity to worsen, while leaving amplitude unchanged. Since gain control has the characteristic that AGC speed is fastest in the range 50~60dB μ , to prevent sag, select an appropriate filter time constant.

IF input impedance is approx. 1K Ω and must be input in balanced type.

2. Video Detector, PLL Section

The PLL system produces a pure carrier wave. The PLL is locked as shown in the diagram below.

The VIDEO DET and APC DET employ a double balanced mixer.

Detector output (pin 28) is 1.5V_{P-P} (V_{CC} = 9V, negative sync). Detector output is almost proportional to supply voltage. Pin 28 is an emitter follower, containing a 2K Ω emitter resistor, and requires an externally attached resistor (2K Ω ~1K Ω) as it is insufficient alone to drive a 4.5MHz trap.

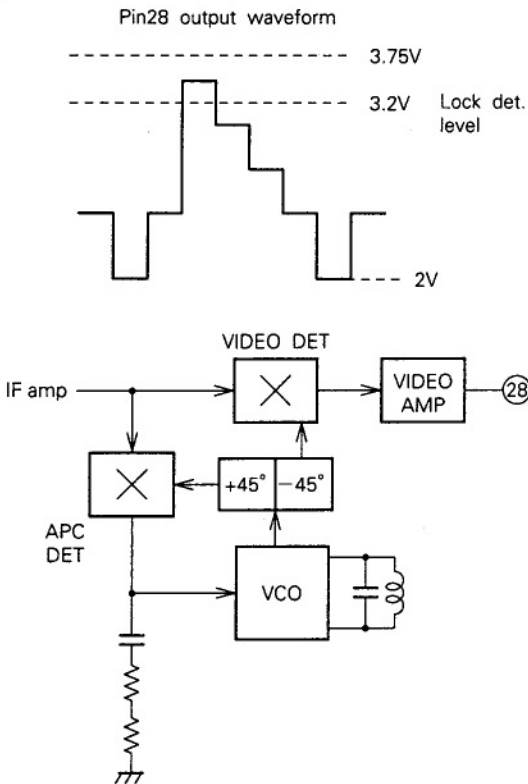

The lock detector determines locked/unlocked conditions by the average level of detector output.

In pin 27, the threshold is 3.2V.

The time constant switch is pin 29.

The VCO circuit diagram is shown to the right, and illustrates how sinking current is varied to adjust frequency.

The variable range falls between -1.7MHz and +1.3MHz at a capacity of 27PF (45.75MHz).

The variable range widens as the capacity decreases, while the temperature drift characteristic and harmonics worsen. V_{CC} and GND of the VCO section are independent of those of the VIF, while the same DC voltage must be supplied as for the VIF.

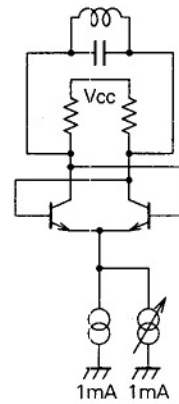

3. SIF Det.

4.5MHz issues from pin 28, however, for M51362SP, inputting 41.25MHz thru pin 11 causes 4.5MHz to be output from pin 15, the product of multiplying 45.75MHz by the carrier wave gained at the VCO.

Since conversion gain is 18dB, which is constant, note that at a lower level than the delay point, the output level is also lowered linearly.

Input impedance is approx. 2K Ω , output pin 15 is an emitter follower type circuit, current sink is 0.6mA, and a 300 Ω resistor is connected in series.

4. AFT

The AFT circuit is of the conventional type. Output is also of the conventional current-drive type.

Since internal operating current is reduced, use a load resistor three times larger than the conventional one. A defeat terminal is not provided here.

Therefore, using the middle point in the coil between pins 26 and 27, lower the voltage of pins 26 and 27 to less than 1V. The internal resistor of pins 26 and 27 is 6K Ω .

M51362SP

PLL-SPLIT VIF/SIF

5. IF/RF AGC

IF AGC input is applied from pin 28 Video Out. → 4.5MHz trap → pin 31 to PNP emitter follower.

The IF AGC amplifier is a two-stage amplifier, with pin 6 & pin 7 serving as a filter terminal.

Output to pin 6 is a current-drive type, and a current sink is 0.5mA.

The RF AGC is a reverse output type; its pin 1 output is illustrated in the figure to the right.

Output voltage is (7.8V~0V) at $V_{cc} = 9V$.

Black spot inverter works before EQ amp. Voltage lower than sync chip by 0.45V (pin 29) is to be threshold.

Clamp voltage is nearly at the white level.

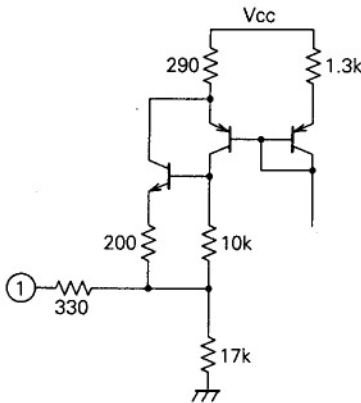

6. EQ Amplifier

Basically, the EQ amplifier is as shown in the diagram to the right.

Providing the feedback to pin 2, it has the frequency characteristic.

It can also be used as an amplifier with a fixed gain.

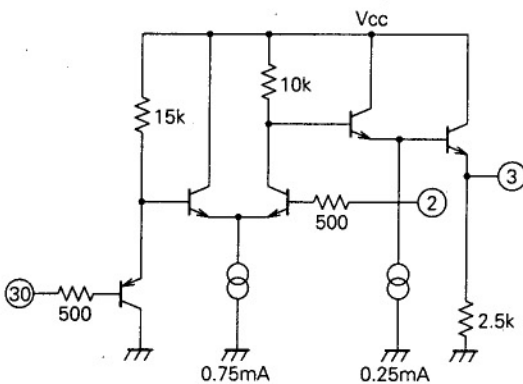

7. SIF Section

As V_{cc} and GND of the SIF section are independent of those of the VIF, the supply voltage of the SIF section can be changed.

The limiter amplifier is a triple amplification device, including an internal differential amplifier. Pin 14 is a DC feedback

terminal.

The resistor between pins 13 and 14 is provided to prevent parasitic oscillation.

The FM detector employs a quadrature detection method and requires a tank coil and damping resistor at pins 17 and 18.

Note that use of a ceramic discriminator would not obtain a good characteristic.

Pin 19 audio output also employs an emitter follower and the output impedance is approx. 700Ω.

Principle of M51362SP PLL Section

M51362SP's PLL section is formed as shown in Fig. 1. The locked loop is indicated by broken lines.

The APC and video detector are double balance-type multipliers, and the LPF is a lag-lead filter with external C.R.

The APC detector is a phase comparator and outputs voltage corresponding to the phase difference between the IF signal and VCO output (output through +45° phase shift device).

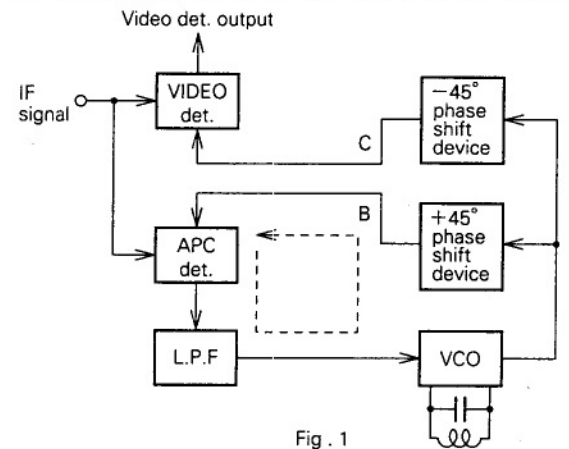

Fig. 1

The phase comparator usually has such a characteristic as the one illustrated in Fig. 2: When the phase angle of B is +90° out-of-phase for the IF signal, the APC output current becomes 0, while APC output current becomes positive when the phase angle lags.

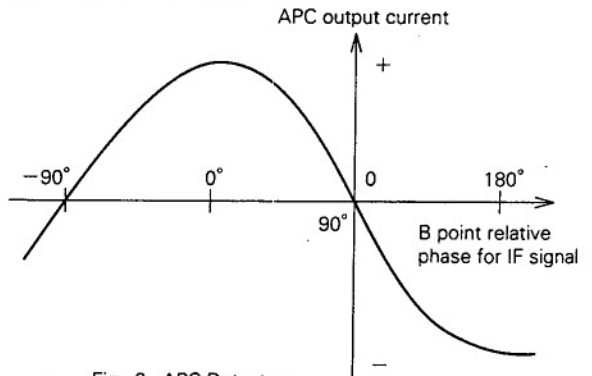

Fig. 2 APC Detector

M51362SP

- PLL-SPLIT VIF/SIF

Output current is converted into voltage, and unnecessary frequency is cut off via LPF. Then, the voltage is applied to VCO as controlled voltage. Here, the VCO characteristic is shown in Fig. 3, and for the IF signal, the phase at B relative to the IF signal is -90° .

The procedure by which the VCO follows the IF signal is described below: For example, when the phase of the IF signal lags (the phase at B relative to the IF signal leads more than -90°), APC output current becomes positive, controlled current increases, frequency tends to decrease and, consequently, the phase lags.

So at point B, the VCO locked in phase angle is -90° . Meanwhile, when the frequency of the IF signal becomes high, APC output is negative, controlled voltage decreases, and the VCO frequency becomes higher, because the instantaneous phase is equivalent to leading.

However, with phase error inversely proportional to loop gain, the VCO locks.

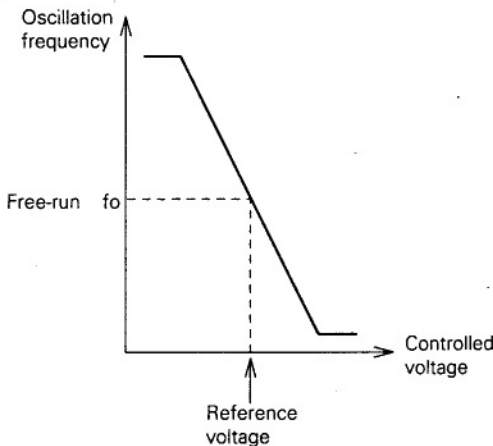

Fig. 3 VCO Characteristic

Free-run frequency is oscillation frequency produced when center voltage is applied to the VCO.

When locked, the input frequency lock range depends on the variable frequency range, and the lower loop gain narrows this range. Description of the capture procedure for the IF signal is omitted here due to its complexity. The capture range is narrower than that of the lock in relation to loop gain, and narrower than the LPF bandwidth.

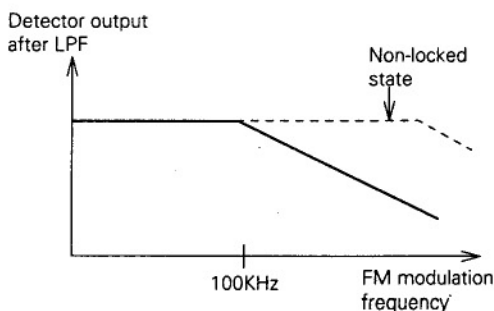

Fig. 4

When the M51362SP is in the non-locked state and a locked condition is detected, the LPF time constant is reduced to widen the capture range.

The frequency response characteristic under the locked state is shown in Fig. 4; cut-off frequency is approx. 100KHz, and is equivalent to the bandwidth of the carrier wave reproduced from the IF signal.

Here, the AM detector section is now described. If, in Fig. 5, the phase at point B is locked at -90° , phase lags by 45° at point A, this means the IF signal carrier wave will be -135° .

Consequently, the carrier wave phase at point C, where the signal is input into the video detector, lags by an additional 45° , producing -180° (out-of-phase).

A correct phase produces the most complete and effective demodulation of the video signal. (See Fig. 5).

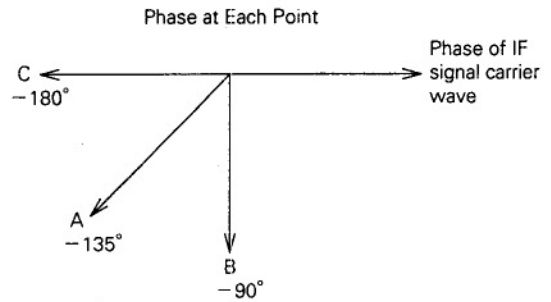

Fig. 5

Fig.6 illustrates the basic circuit of the phase shift device. Each phase shift device comprises an LPF (-45°), an HPF ($+45^\circ$) having simple C and R and set so that the phase will rotate by $\pm 45^\circ$ at 45.75MHz.

Consequently, although the phase rotation varies in the other IF band, the relative phase angle is 90° , independent of frequency, as the values of R and C are set equal to one another.

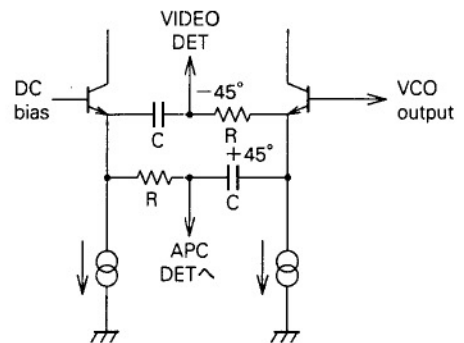

Fig. 6

M51362SP

PLL-SPLIT VIF/SIF

SPECIAL PARTS

Coil Specification

f = 45.75MHz

- 1) VCO coil pin ⑳, ㉑

Qu	Co(pF)	Turns	Bobbin	Wire
92±20%	27 Stray 7.2	(1-6) $6\frac{1}{2}$ t	10K type	0.12Φ OUEW

Variable range widens as Co is reduced.

- 2) AFT coil pin ㉒, ㉓

Qu	Co(pF)	Turns	Bobbin	Wire
84±20%	59±6%	(1-6) $4\frac{1}{4}$ t	10K type	0.12Φ OUEW

- 3) SIF coil pin ㉔

Filter passing only 41.25MHz. Can be used in AFT coil.
When SAW filter (41.25MHz) is used, compensation for loss is necessary.

- 4) SIF FM det. coil pin ㉕, ㉖

Qu	Co(pF)	Turns	Bobbin	Wire
60±20%	68pF	(4-6) 36t	10K type	0.12Φ OUEW