

1310/1550 nm 10 G XFP ROSA



The high-reliability Lumentum 1310/1550 nm 10 G XFP ROSA receiver optical sub-assembly (ROSA) product, designed specifically for the XFP transceiver, provides excellent performance over extended operating temperatures in high-speed applications up to 10 G. The product integrates PIN and TIA chips in a custom hermetic TO46 package. Each device is actively aligned to a precision OSA housing using a proprietary alignment algorithm and is tested to precise requirements. An optional, controlled-impedance flex OSA-PCBA connector provides the user with optimum performance.

Key Features

- Handles data rates up to 10 G
- Supports 1310 nm and 1550 nm multi-rate applications
- Operates from -40°C to 85°C
- Includes differential output
- Supports received signal strength indicator (RSSI) function

Applications

- 10 G Ethernet 10GBASE-LR/ER
- SONET OC-192 SR1/IR2

Compliance

- RoHS 6

Dimensions Diagram

(Specifications in mm unless otherwise noted.)

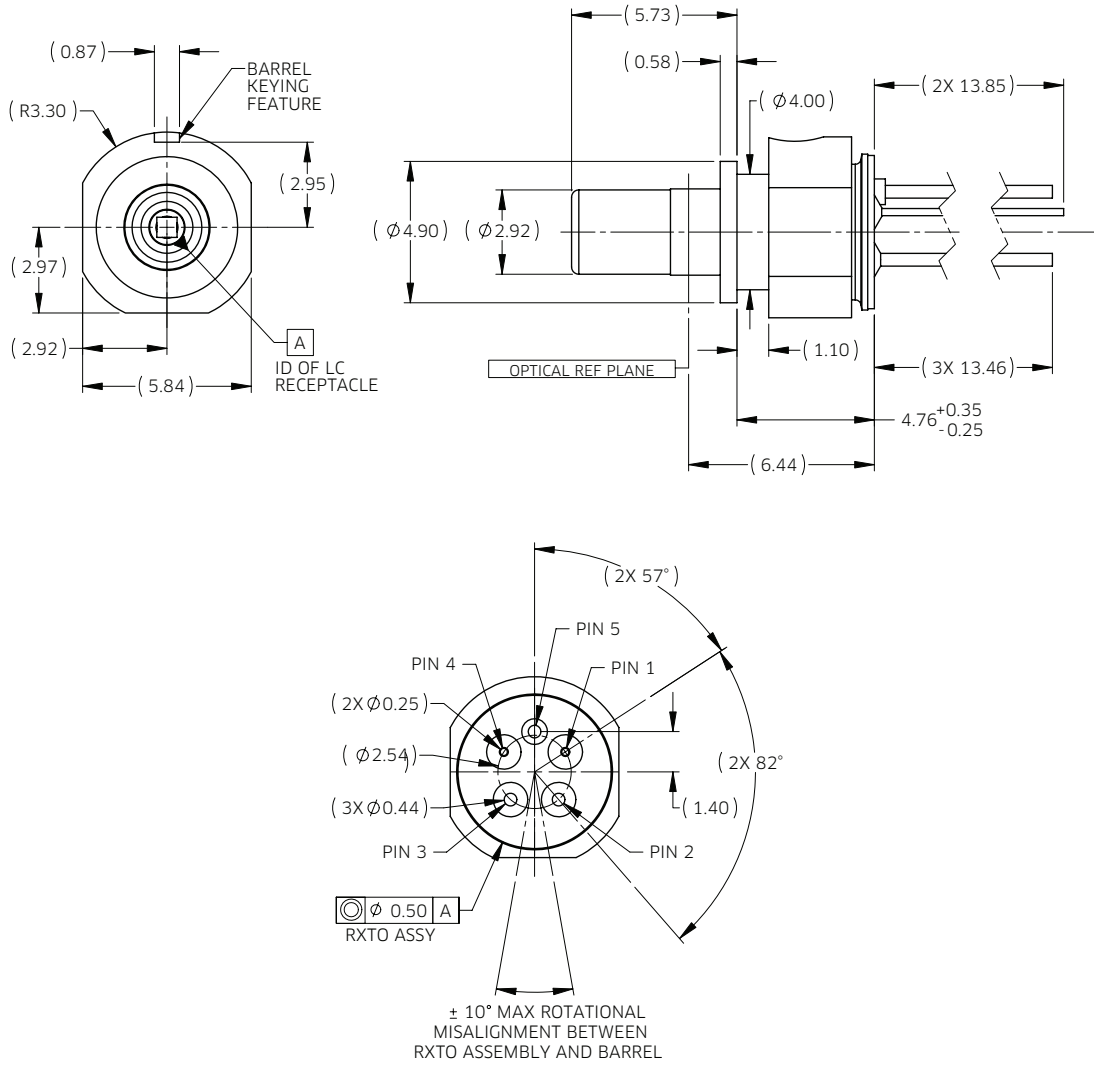

Pinout

Pin	Symbol	Description
1	OUT+	Non-inverting output
2	V _{cc}	Power supply
3	RSSI	Received signal strength indicator
4	OUT-	Inverting output
5	GND	Case & RF ground

Electrical Schematics for Flexible Printed Circuit (FPC)

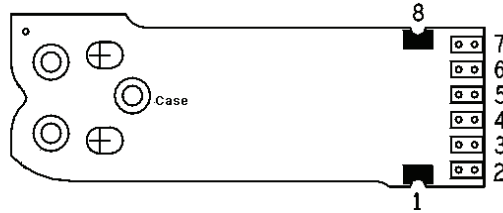

Note:
Pin definition for FPC can open to customer design

Pinout

Pin	Symbol
1	GND
2	V _{cc}
3	GND
4	VOUT -N
5	VOUT +P
6	GND
7	Monitor
8	GND

Absolute Maximum Ratings

Parameter	Symbol	Rating
Storage temperature	T _{STG}	-40 to +85°C
Operating case temperature (T _{op})	T _{op}	-40 to +85°C
Supply voltage	V _{cc}	-0.3 to 4.0 V
Voltage at either output	V _{io}	-0.3 to 4.0 V
Current into any input or output	I _{io}	-8 to 8 mA
ESD threshold (HBM)	V _{ESD}	300 V
Maximum incident optical power	P ₀	+4.5 dBm

Note:
All specifications are at T_a = 25°C unless otherwise stated

Specifications

Parameter	Symbol	Conditions	Minimum	Typical	Maximum
TIA supply voltage	V _{cc}		3.15 V	3.30 V	3.45 V
TIA supply current	I _{cc}	V _{cc} =3.3 V	—	28 mA	41mA
Wavelength	λ		1260 nm	—	1565 nm
Photodiode responsivity	R	Measured at 1310 nm	0.75 A/W	—	—
Single ended output impedance	Z _{out}		40 Ω	50 Ω	60 Ω
Power consumption	P _e		—	100 mW	—
RSSI offset current (no light) ¹	I _{dRSSI}		3.5 μA	10 μA	16 μA
RSSI gain internal bias	A _{RSSI}		0.48 A/A	0.50 A/A	0.52 A/A
Data rate	B		9.95 G	—	11.35 G
RF bandwidth (-3 dB)	BW	Small signal bandwidth	7 GHz	—	—
Low frequency cut-off (-3 dB)	f _{c, low}		—	30 KHz	100 KHz
Sensitivity average power	Sens_Avg	10.709 G, NRZ, PRBS 2 ³¹ -1 1550 nm, ExtRatio>10 dB, BER=10 ⁻¹²	—	-19.5 dBm	—

Specifications (Continued)

Parameter	Symbol	Conditions	Minimum	Typical	Maximum
Stressed sensitivity OMA XFP-SR1 XFP-IR2	SRS_10GbaseL SRS_10GbaseE	IEEE802.3ae, 10GBase-L stress IEEE802.3ae, 10GBase-E stress	- -	-16 dBm -16 dBm	- -
Overload	P _{max}	10.709 G, NRZ, PRBS 2 ³¹ -1, 1260 - 1355 nm, Ext Ratio=13.0 dB, BER=10 ⁻¹²	1.5 dBm	-	-
Optical return loss XFP-SR1 XFP-IR2	ORL	1290 - 1330 nm 1530 - 1565 nm	- -	- -	-14 dB -28 dB
Transimpedance (single-ended)	Z _r		5000 Ω	7000 Ω	10000 Ω
Maximum differential output voltage	V _{out, D, Max}		240 mV _{PP}	280 mV _{PP}	350 mV _{PP}
TIA input referred RMS noise		10 GHz bandwidth	-	0.9 μA	1.6 μA

Note:

All parameters are over temperature and end-of-life unless otherwise stated.

- The RSSI (received signal strength indicator) function is used to mirror the photodiode output with an analog current output. This current has been defined at certain proportion ratio to the photodiode output current. This function requires a resistive load to ground (GND). The voltage gain can be adjusted for the intended application by choosing different external resistor. Offset is added to improve accuracy below 5 μA. When measured without input current (no light) the offset can be subtracted as a constant offset from RSSI measurements. RSSI current output will operate from sensitivity to overload.

Electrostatic Discharge (ESD)

ESD protection is imperative. Use of grounding straps, antistatic mats, and other standard ESD protective equipment is required when handling or testing a junction photodiode. Fiber pigtail should be handled with less than 10 N pull and with bending radius greater than one inch. Soldering temperature of the leads should not exceed 260°C for more than 10 seconds.

Ordering Information

For more information on this or other products and their availability, please contact your local Lumentum account manager or Lumentum directly at customer.service@lumentum.com.

Product Code	Description
21141321	10G 5L LC ROSA for XFP IR2 with flex
21141320	10G 5L LC ROSA for XFP SR1 with flex



North America
Toll Free: 844 810 LITE (5483)

Outside North America
Toll Free: 800 000 LITE (5483)

China
Toll Free: 400 120 LITE (5483)

© 2015 Lumentum Operations LLC
Product specifications and descriptions in this document are subject to change without notice.