

MOSEL VITELIC **V52C4258**
MULTIPOINT VIDEO RAM WITH
256K X 4 DRAM AND 512 X 4 SAM

HIGH PERFORMANCE V52C4258	60	70	80	10
Max. $\overline{\text{RAS}}$ Access Time, (t_{RAC})	60 ns	70 ns	80 ns	100 ns
Max. $\overline{\text{CAS}}$ Access Time, (t_{CAC})	15 ns	20 ns	25 ns	25 ns
Max. Column Address Access Time, (t_{AA})	30 ns	35 ns	40 ns	50 ns
Min. Fast Page Mode Cycle Time, (t_{PC})	40 ns	45 ns	50 ns	55 ns
Min. Read/Write Cycle Time, (t_{RC})	120 ns	140 ns	150 ns	180 ns
Max. Serial Access Time, (t_{SCA})	25 ns	25 ns	25 ns	25 ns
Min. Serial Port Cycle Time, (t_{SCC})	30 ns	30 ns	30 ns	30 ns

Features

- Organization
 - RAM Port: 262,144 words x 4 bits
 - SAM Port: 512 words x 4 bits
- RAM Port
 - Fast Page Mode, Read-Modify-Write, Write-Per-Bit
 - Block Write/Flash Write
 - Color Register Load/Read
 - 512 Refresh Cycles/8 ms
 - $\overline{\text{CAS}}$ -before- $\overline{\text{RAS}}$ Refresh, Hidden Refresh, $\overline{\text{RAS}}$ -only Refresh
- SAM Port
 - High Speed Serial Read/Write Capability
 - 512 Tap Locations
 - Fully Static Register
- RAM-SAM Bidirectional Transfer
 - Read/Write/Pseudo Write Transfer
 - Real Time Read Transfer
 - Split Read/Write Transfer
- Low Power Dissipation
 - RAM Port Operating Alone – 85 mA
 - SAM Port Operating Alone – 50 mA
- Low CMOS Standby Current – 7 mA
- Package
 - 28 pin 400 mil SOJ
 - 28 pin 400 mil ZIP

Description

The V52C4258 VRAM is equipped with a 262,144-words by 4-bits dynamic random access memory (RAM) port and a 512-words by 4-bits static serial access memory (SAM) port. The V52C4258 supports three types of operations: random access to and from the RAM port, high speed serial access to and from the SAM port, and bidirectional transfer of data between any selected row in the RAM port and the SAM port. The RAM port and the SAM port can be accessed independently except when data is being transferred between them internally.

In addition to the conventional multipoint video RAM operating modes, the V52C4258 features the block write and flash write functions on the RAM port and a split register data transfer capability on the SAM port.

3

Device Usage Chart

Operating Temperature Range	Package Outline		Access Time (ns)				Power	Temperature Mark
	K	Z	60	70	80	100	Std	
0°C–70°C	•	•	•	•	•	•	•	Blank

Description	Pkg.	Pin Count
SOJ	K	28
ZIP	Z	28

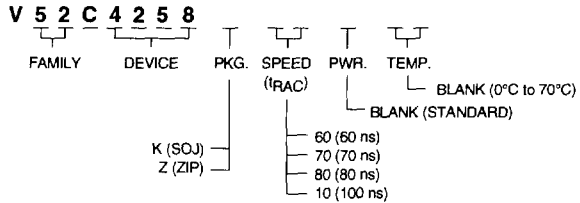

28 Lead Pin Configuration

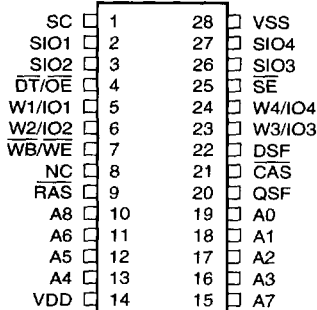

K - SOJ

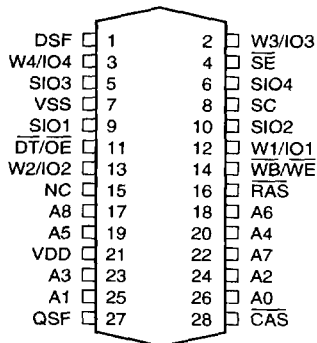

Z - ZIP

Pin Names

Name	Description
A0-A8	Address Inputs
RAS	Row Address Strobe
CAS	Column Address Strobe
DT/OE	Data Transfer/Output Enable
WB/WE	Write per Bit/Write Enable
DSF	Special Function Control
W1/IO1-W4/IO4	Write Mask/Data In, Out
SC	Serial Clock
SE	Serial Enable
SIO1-SIO4	Serial Input/Output
QSF	Special Flag Output
VDD/VSS	Power (5V)/Ground
NC	No Connection

Absolute Maximum Ratings*

Ambient Temperature

Under Bias -10°C to +80°C

Storage Temperature (plastic) -55°C to +125°C

Voltage Relative to V_{SS} -1.0 to +7.0 V

Short Circuit Out Current 50 mA

Power Dissipation 1 W

*Note: Operation above Absolute Maximum Ratings can adversely affect device reliability.

Capacitance*

$T_A = 25^\circ\text{C}$, $V_{DD} = 5\text{ V} \pm 10\%$, $V_{SS} = 0\text{ V}$, $f = 1\text{ MHz}$

Symbol	Parameter	Min.	Max.	Unit
C_{IN}	Input Capacitance		7	pF
$C_{IN/OUT}$	Input/Output Capacitance		9	pF
C_{OUT}	Output Capacitance (QSF)		9	pF

*Note: Capacitance is sampled and not 100% tested.

Functional Diagram

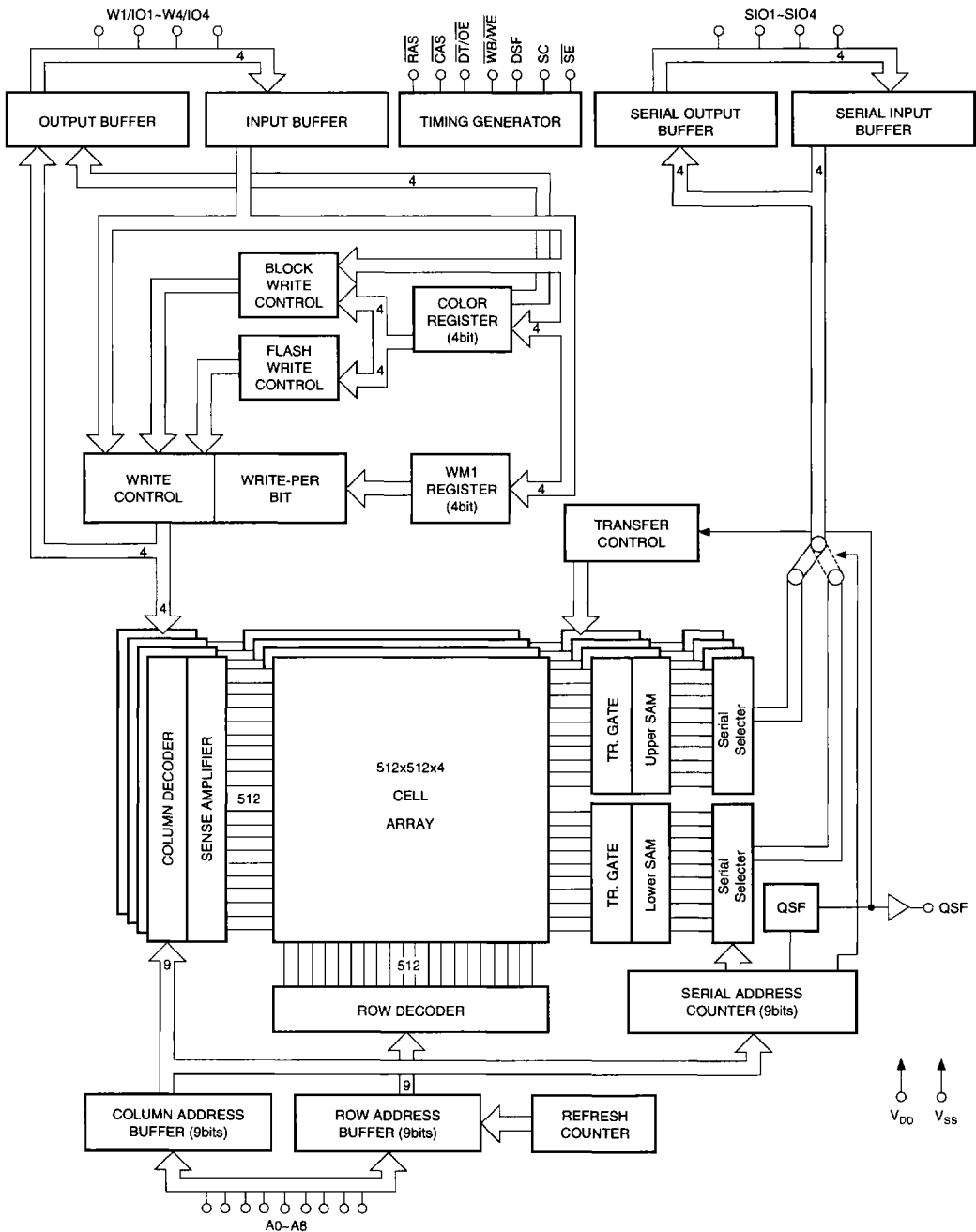

3

DC and Operating Characteristics

 ($V_{DD} = 5V \pm 10\%$, $T_A = 0-70^\circ\text{C}$)

Symbol	Parameter (RAM Port)	SAM Port	-60		-70		-80		-10		Unit	Note
			Min.	Max.	Min.	Max.	Min.	Max.	Min.	Max.		
I_{DD1}	Operating Current $\overline{\text{RAS}}$, $\overline{\text{CAS}}$ Cycling, $t_{RC} = t_{RC} \text{ Min.}$	Standby		95		85		75		65	mA	1,2
I_{DD1A}		Active		130		120		110		100	mA	1,2
I_{DD2}	Standby Current $\overline{\text{RAS}}$, $\overline{\text{CAS}} = V_{IH}$	Standby		7		7		7		7	mA	
I_{DD2A}		Active		55		50		45		40	mA	1,2
I_{DD3}	RAS-Only Refresh Current $\overline{\text{RAS}}$ Cycling, $\overline{\text{CAS}} = V_{IH}$, $t_{RC} = t_{RC} \text{ Min.}$	Standby		95		85		75		65	mA	1,2
I_{DD3A}		Active		130		120		110		100	mA	1,2
I_{DD4}	Page Mode Current $\overline{\text{RAS}} = V_{IL}$, $\overline{\text{CAS}}$ Cycling, $t_{PC} = t_{PC} \text{ Min.}$	Standby		75		70		65		60	mA	1,2
I_{DD4A}		Active		130		120		110		100	mA	1,2
I_{DD5}	CAS-before-RAS Refresh Current $\overline{\text{RAS}}$ Cycling, $\overline{\text{CAS}}$ before $\overline{\text{RAS}}$, $t_{RC} = t_{RC} \text{ Min.}$	Standby		95		85		75		65	mA	1,2
I_{DD5A}		Active		130		120		110		100	mA	1,2
I_{DD6}	Data Transfer Current $\overline{\text{RAS}}$, $\overline{\text{CAS}}$ Cycling, $t_{RC} = t_{RC} \text{ Min.}$	Standby		95		85		75		65	mA	1,2
I_{DD6A}		Active		130		120		110		100	mA	1,2
I_{DD7}	Flash Write Current $\overline{\text{RAS}}$, $\overline{\text{CAS}}$ Cycling, $t_{RC} = t_{RC} \text{ Min.}$	Standby		95		85		75		65	mA	1,2
I_{DD7A}		Active		130		120		110		100	mA	1,2
I_{DD8}	Block Write Current $\overline{\text{RAS}}$, $\overline{\text{CAS}}$ Cycling, $t_{RC} = t_{RC} \text{ Min.}$	Standby		95		85		75		65	mA	1,2
I_{DD8A}		Active		130		120		110		100	mA	1,2
$I_{I(L)}$	Input Leakage Current $0V \leq V_{IN} \leq 5.5V$, all other pins not under test = $0V$		-10	10	-10	10	-10	10	-10	10	μA	
$I_{O(L)}$	Output Leakage Current $0V \leq V_{OUT} \leq 5.5V$, Output Disable		-10	10	-10	10	-10	10	-10	10	μA	
V_{OH}	Output "H" Level Voltage $I_{OUT} = -2 \text{ mA}$		2.4		2.4		2.4		2.4		V	
V_{OL}	Output "L" Level Voltage $I_{OUT} = 2 \text{ mA}$			0.4		0.4		0.4		0.4	V	
V_{IH}	Input High Voltage		2.4	$V_{DD}+1$	2.4	$V_{DD}+1$	2.4	$V_{DD}+1$	2.4	$V_{DD}+1$	V	
V_{IL}	Input Low Voltage		-1.0	0.8	-1.0	0.8	-1.0	0.8	-1.0	0.8	V	

AC Electrical Characteristics Notes: 3, 4, 5

Symbol	Parameter	-60		-70		-80		-10		Unit	Notes
		Min.	Max.	Min.	Max.	Min.	Max.	Min.	Max.		
t_{RC}	Random Read or Write Cycle Time	120		140		150		180		ns	
t_{RMW}	Read-Modify-Write Cycle Time	175		195		195		235		ns	
t_{PC}	Fast Page Mode Cycle Time	40		45		50		55		ns	
t_{PRMW}	Fast Page Mode Read-Modify-Write Cycle Time	85		90		90		100		ns	
t_{RAC}	Access Time from \overline{RAS}		60		70		80		100	ns	6,12
t_{AA}	Access Time from Column Address		30		35		40		50	ns	6,12
t_{CAC}	Access Time from \overline{CAS}		15		20		25		25	ns	6,13
t_{CPA}	Access Time from \overline{CAS} Precharge		35		40		45		50	ns	6,13
t_{OFF}	Output Buffer Turn-Off Delay	0	15	0	20	0	20	0	20	ns	8
t_T	Transition Time (Rise and Fall)	3	35	3	35	3	35	3	35	ns	5
t_{RP}	\overline{RAS} Precharge Time	50		60		60		70		ns	
t_{RAS}	\overline{RAS} Pulse Width	60	10K	70	10K	80	10K	100	10K	ns	
t_{RASP}	\overline{RAS} Pulse Width (Fast Page Mode only)	60	100K	70	100K	80	100K	100	100K	ns	
t_{RSH}	\overline{RAS} Hold Time	15		20		25		25		ns	
t_{CSH}	\overline{CAS} Hold Time	60		70		80		100		ns	
t_{CAS}	\overline{CAS} Pulse Width	15	10K	20	10K	25	10K	25	10K	ns	
t_{RCD}	\overline{RAS} to \overline{CAS} Delay Time	20	45	20	50	20	55	20	75	ns	12
t_{RAD}	\overline{RAS} to Column Address Delay Time	15	30	15	35	15	40	20	50	ns	12
t_{RAL}	Column Address to \overline{RAS} Lead Time	30		35		40		55		ns	
t_{CRP}	\overline{CAS} to \overline{RAS} Precharge Time	10		10		10		10		ns	
t_{CPN}	\overline{CAS} Precharge Time	10		10		10		10		ns	
t_{CP}	\overline{CAS} Precharge Time (Fast Page Mode)	10		10		10		10		ns	
t_{ASR}	Row Address Setup Time	0		0		0		0		ns	
t_{RAH}	Row Address Hold Time	10		10		10		10		ns	
t_{ASC}	Column Address Setup Time	0		0		0		0		ns	
t_{CAH}	Column Address Hold Time	10		15		15		15		ns	
t_{AR}	Column Address Hold Time referenced to \overline{RAS}	50		55		55		70		ns	
t_{RCS}	Read Command Setup Time	0		0		0		0		ns	
t_{RCH}	Read Command Hold Time	0		0		0		0		ns	9
t_{RRH}	Read Command Hold Time referenced to \overline{RAS}	0		0		0		0		ns	9
t_{WCH}	Write Command Hold Time	10		15		15		15		ns	
t_{WCR}	Write Command Hold Time referenced to \overline{RAS}	50		55		55		70		ns	

AC Electrical Characteristics (Cont'd)

Symbol	Parameter	-60		-70		-80		-10		Unit	Notes
		Min.	Max.	Min.	Max.	Min.	Max.	Min.	Max.		
t _{WP}	Write Command Pulse Width	10		15		15		15		ns	
t _{RWL}	Write Command to $\overline{\text{RAS}}$ Lead Time	15		20		20		25		ns	
t _{CWL}	Write Command to $\overline{\text{CAS}}$ Lead Time	15		20		20		25		ns	
t _{DS}	Data Setup Time	0		0		0		0		ns	10
t _{DH}	Data Hold Time	15		15		15		15		ns	10
t _{DHR}	Data Hold Time referenced to $\overline{\text{RAS}}$	50		55		55		70		ns	
t _{WCS}	Write Command Setup Time	0		0		0		0		ns	11
t _{RWD}	$\overline{\text{RAS}}$ to $\overline{\text{WE}}$ Delay Time	90		100		100		130		ns	11
t _{AWD}	Column Address to $\overline{\text{WE}}$ Delay Time	60		65		65		80		ns	11
t _{CWD}	$\overline{\text{CAS}}$ to $\overline{\text{WE}}$ Delay Time	40		45		45		55		ns	11
t _{DZC}	Data to $\overline{\text{CAS}}$ Delay Time	0		0		0		0		ns	
t _{DZO}	Data to $\overline{\text{OE}}$ Delay Time	0		0		0		0		ns	
t _{OEa}	Access Time from $\overline{\text{OE}}$		15		20		20		25	ns	6
t _{OEZ}	Output Buffer Turn-Off Delay from $\overline{\text{OE}}$	0	10	0	10	0	10	0	20	ns	8
t _{OEED}	$\overline{\text{OE}}$ to Data Delay Time	10		10		10		20		ns	
t _{OEH}	$\overline{\text{OE}}$ Command Hold Time	10		10		10		20		ns	
t _{ROH}	$\overline{\text{RAS}}$ Hold Time referenced to $\overline{\text{OE}}$	10		15		15		15		ns	
t _{CSR}	$\overline{\text{CAS}}$ Setup Time for $\overline{\text{Cas}}$ -before- $\overline{\text{RAS}}$ Cycle	10		10		10		10		ns	
t _{CHR}	$\overline{\text{CAS}}$ Hold Time for $\overline{\text{CAS}}$ -before- $\overline{\text{RAS}}$ Cycle	10		10		10		10		ns	
t _{RPC}	$\overline{\text{RAS}}$ Precharge to $\overline{\text{CAS}}$ Active Time	0		0		0		0		ns	
t _{REF}	Refresh Period		8		8		8		8	ms	
t _{WSR}	$\overline{\text{WB}}$ Setup Time	0		0		0		0		ns	
t _{RWH}	$\overline{\text{WB}}$ Hold Time	15		15		15		15		ns	
t _{FSR}	DSF Setup Time referenced to $\overline{\text{RAS}}$	0		0		0		0		ns	
t _{RFH}	DSF Hold Time referenced to $\overline{\text{RAS}}$ (1)	15		15		15		15		ns	
t _{FHR}	DSF Hold Time referenced to $\overline{\text{RAS}}$ (2)	50		55		55		70		ns	
t _{FSC}	DSF Setup Time referenced to $\overline{\text{CAS}}$	0		0		0		0		ns	
t _{CFH}	DSF Hold Time referenced to $\overline{\text{CAS}}$	15		15		15		15		ns	
t _{MS}	Write-Per-Bit Mask Data Setup Time	0		0		0		0		ns	
t _{MH}	Write-Per-Bit Mask Data Hold Time	15		15		15		15		ns	
t _{THS}	$\overline{\text{DT}}$ High Setup Time	0		0		0		0		ns	
t _{THH}	$\overline{\text{DT}}$ High Hold Time	15		15		15		15		ns	
t _{TLS}	$\overline{\text{DT}}$ Low Setup Time	0		0		0		0		ns	

AC Electrical Characteristics (Cont'd)

Symbol	Parameter	-60		-70		-80		-10		Unit	Notes
		Min.	Max.	Min.	Max.	Min.	Max.	Min.	Max.		
t _{TLH}	\overline{DT} Low Hold Time	15	10K	15	10K	15	10K	15	10K	ns	
t _{RTH}	\overline{DT} Low Hold Time referenced to \overline{RAS} (Real Time Read Transfer)	55	10K	60	10K	65	10K	80	10K	ns	
t _{ATH}	\overline{DT} Low Hold Time referenced to Column Address (Real Time Read Transfer)	20		25		30		30		ns	
t _{CTH}	\overline{DT} Low Hold Time referenced to \overline{CAS} (Real Time Read Transfer)	15		20		25		25		ns	
t _{ESR}	\overline{SE} Setup Time referenced to \overline{RAS}	0		0		0		0		ns	
t _{REH}	\overline{SE} Hold Time referenced to \overline{RAS}	15		15		15		15		ns	
t _{TRP}	\overline{DT} to \overline{RAS} Precharge Time	50		60		60		70		ns	
t _{TP}	\overline{DT} Precharge Time	20		20		20		30		ns	
t _{RSD}	\overline{RAS} to First SC Delay Time (Read Transfer)	65		70		80		100		ns	
t _{ASD}	Column Address to First SC Delay Time (Read Transfer)	40		45		45		50		ns	
t _{CSD}	\overline{CAS} to First SC Delay Time (Read Transfer)	20		20		25		25		ns	
t _{TSL}	Last SC to \overline{DT} Lead Time (Real Time Read Transfer)	5		5		5		5		ns	
t _{TSD}	\overline{DT} to First SC Delay Time (Read Transfer)	15		15		15		15		ns	
t _{SRS}	Last SC to \overline{RAS} Setup Time (Serial Input)	20		25		25		30		ns	
t _{SRD}	\overline{RAS} to First SC Delay Time (Serial Input)	20		20		20		25		ns	
t _{SDD}	\overline{RAS} to Serial Input Delay Time	40		40		40		50		ns	
t _{SDZ}	Serial Output Buffer Turn-Off Delay from \overline{RAS} (Pseudo Write Transfer)	10	40	10	40	10	40	10	50	ns	8
t _{SCC}	SC Cycle Time	30		30		30		30		ns	
t _{SC}	SC Pulse Width (SC High Time)	10		10		10		10		ns	
t _{SCP}	SC Precharge Time (SC Low Time)	10		10		10		10		ns	
t _{SCA}	Access Time from SC		25		25		25		25	ns	7
t _{SOH}	Serial Output Hold Time from SC	5		5		5		5		ns	
t _{SDS}	Serial Input Setup Time	0		0		0		0		ns	
t _{SDH}	Serial Input Hold Time	15		15		15		15		ns	
t _{SEA}	Access Time from \overline{SE}		25		25		25		25	ns	7
t _{SE}	\overline{SE} Pulse Width	25		25		25		25		ns	
t _{SEP}	\overline{SE} Precharge Time	25		25		25		25		ns	
t _{SEZ}	Serial Output Buffer Turn-Off Delay from \overline{SE}	0	20	0	20	0	20	0	20	ns	8
t _{SEZ}	Serial Input to \overline{SE} Delay Time	0		0		0		0		ns	

AC Electrical Characteristics (Cont'd)

Symbol	Parameter	-60		-70		-80		-10		Unit	Notes
		Min.	Max.	Min.	Max.	Min.	Max.	Min.	Max.		
t _{SZS}	Serial Input to First SC Delay Time	0		0		0		0		ns	
t _{SWS}	Serial Write Enable Setup Time	5		5		5		5		ns	
t _{SWH}	Serial Write Enable Hold Time	15		15		15		15		ns	
t _{SWIS}	Serial Write Disable Setup Time	5		5		5		5		ns	
t _{SWIH}	Serial Write Disable Hold Time	15		15		15		15		ns	
t _{STS}	Split Transfer Setup Time	25		25		30		30		ns	
t _{STH}	Split Transfer Hold Time	25		25		30		30		ns	
t _{SQD}	SC-QSF Delay Time		25		25		25		25	ns	
t _{TQD}	\overline{DT} -QSF Delay Time		25		25		25		25	ns	
t _{CQD}	\overline{CAS} -QSF Delay Time		35		35		35		35	ns	
t _{RQD}	\overline{RAS} -QSF Delay Time		75		75		75		85	ns	

Notes

1. These parameters depend on cycle rate.
2. These parameters depend on output loading. Specified values are obtained with the output open.
3. An initial pause of 200 μ s is required after power-up, followed by any 8 $\overline{\text{RAS}}$ cycles ($\overline{\text{DT}}/\overline{\text{OE}}$ "high") and any 8 SC cycles before proper device operation is achieved. In case of using internal refresh counter, a minimum of 8 $\overline{\text{CAS}}$ -before- $\overline{\text{RAS}}$ initialization cycles instead of 8 $\overline{\text{RAS}}$ cycles are required.
4. AC measurements assume $t_T = 5$ ns.
5. V_{IH} (min.) and V_{IL} (max.) are reference levels for measuring timing of input signals. Also, transition times are measured between V_{IH} and V_{IL} .
6. RAM port outputs are measured with a load equivalent to 1 TTL load and 100 pF. D_{OUT} reference levels: $V_{OH}/V_{OL} = 2.0V/0.8V$.
7. SAM port outputs are measured with a load equivalent to 1 TTL load and 30 pF. D_{OUT} reference levels: $V_{OH}/V_{OL} = 2.0V/0.8V$.
8. t_{OFF} (max.), t_{OEZ} (max.), t_{SDZ} (max.) and t_{SEZ} (max.) define the time at which the outputs achieve the open circuit condition and are not referenced to output voltage levels.
9. Either t_{RCH} or t_{RRH} must be satisfied for a read cycle.
10. These parameters are referenced to $\overline{\text{CAS}}$ leading edge of early write cycles and to $\overline{\text{WB}}/\overline{\text{WE}}$ leading edge in $\overline{\text{OE}}$ -controlled write cycles and read-modify-write cycles.
11. t_{WCS} , t_{RWD} , t_{CWD} and t_{AWD} are not restrictive operating parameters. They are included in the data sheet as electrical characteristics only. If $t_{WCS} \geq t_{WCS}$ (min.), the cycle is an early write cycle and the data out pin will remain open circuit (high impedance) throughout the entire cycle. If $t_{RWD} \geq t_{RWD}$ (min.), $t_{CWD} \geq t_{CWD}$ (min.) and $t_{AWD} \geq t_{AWD}$ (min.), the cycle is a read-modify-write cycle and the data out will contain data read from the selected cell. If neither of the above sets of conditions is satisfied, the condition of the data out (at access time) is indeterminate.
12. Operation within the t_{RCD} (max.) limit ensures that t_{RAC} (max.) can be met. t_{RCD} (max.) is specified as a reference point only; if t_{RCD} is greater than the specified t_{RCD} (max.) limit, then access time is controlled by t_{CAC} .
13. Operation within the t_{RAD} (max.) limit ensures that t_{RAC} (max.) can be met. t_{RAD} (max.) is specified as a reference point only; if t_{RAD} is greater than the specified t_{RAD} (max.) limit, then access time is controlled by t_{AA} .

TIMING WAVEFORMS

Read Cycle

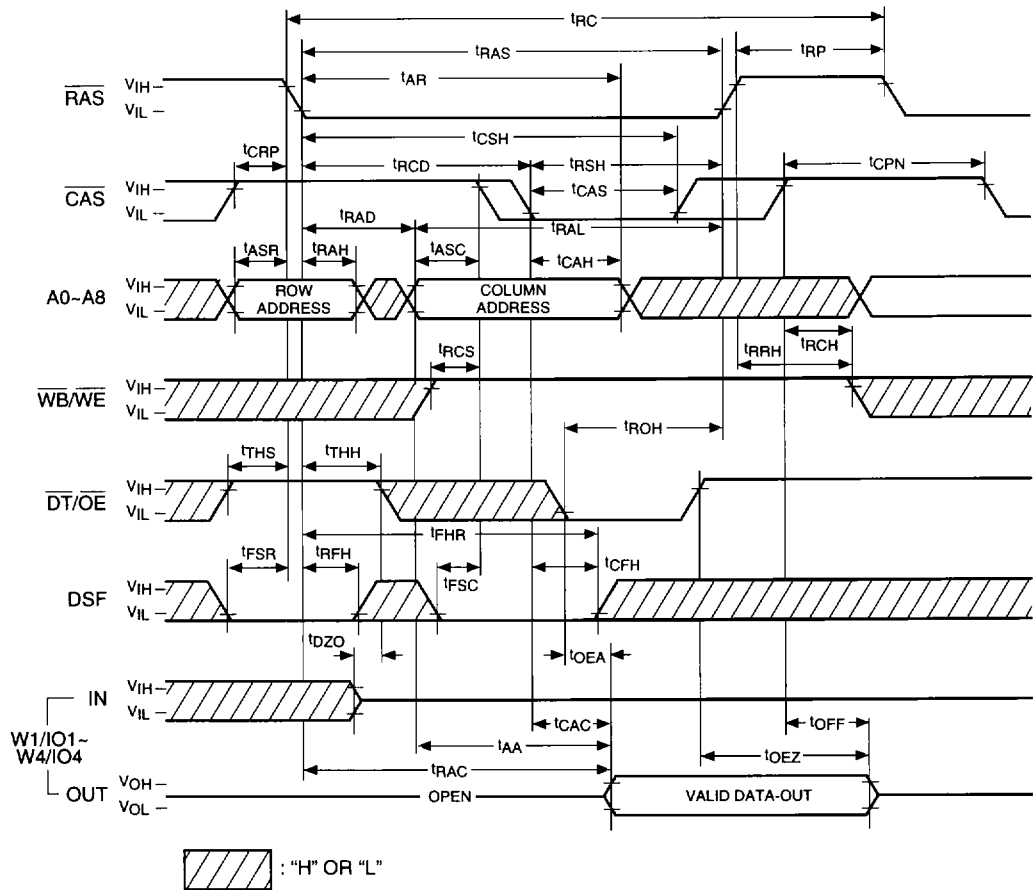

Write Cycle (Early Write)

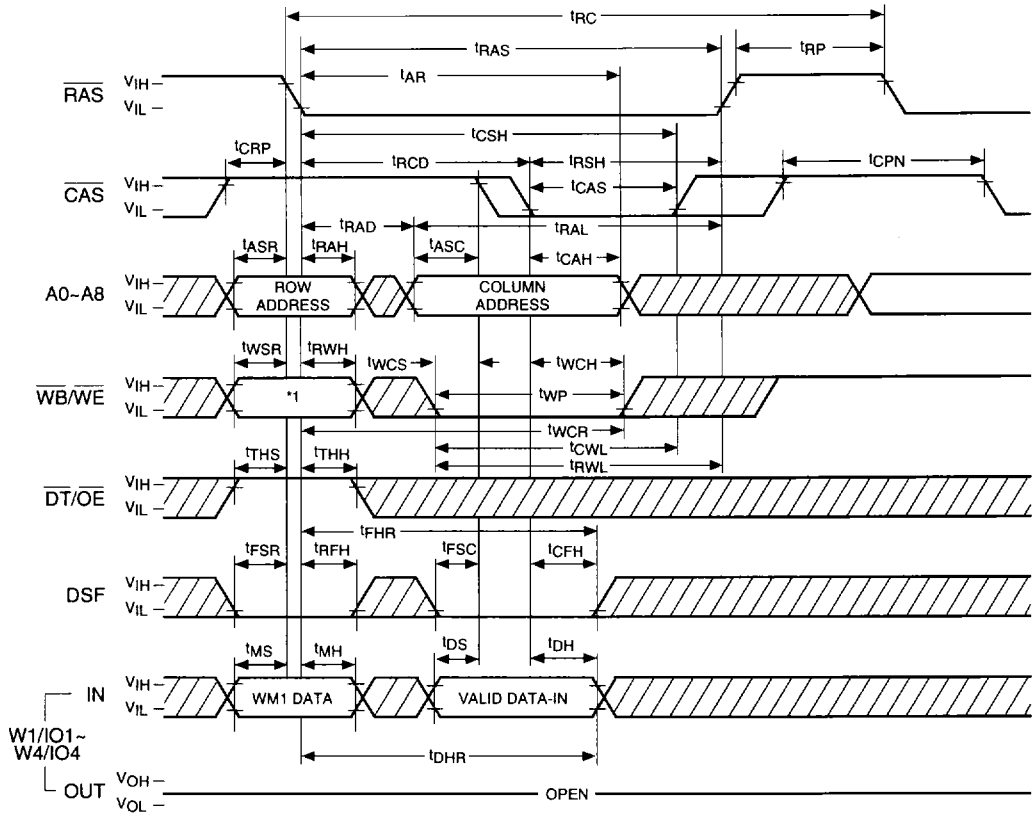

 : "H" OR "L"

*1 WB/WE	W1/IO1~W4/IO4	Cycle
0	WM1 data	Write per bit
1	Don't Care	Normal Write

WM1 data: 0: Write Disable
1: Write Enable

RAS Only Refresh Cycle

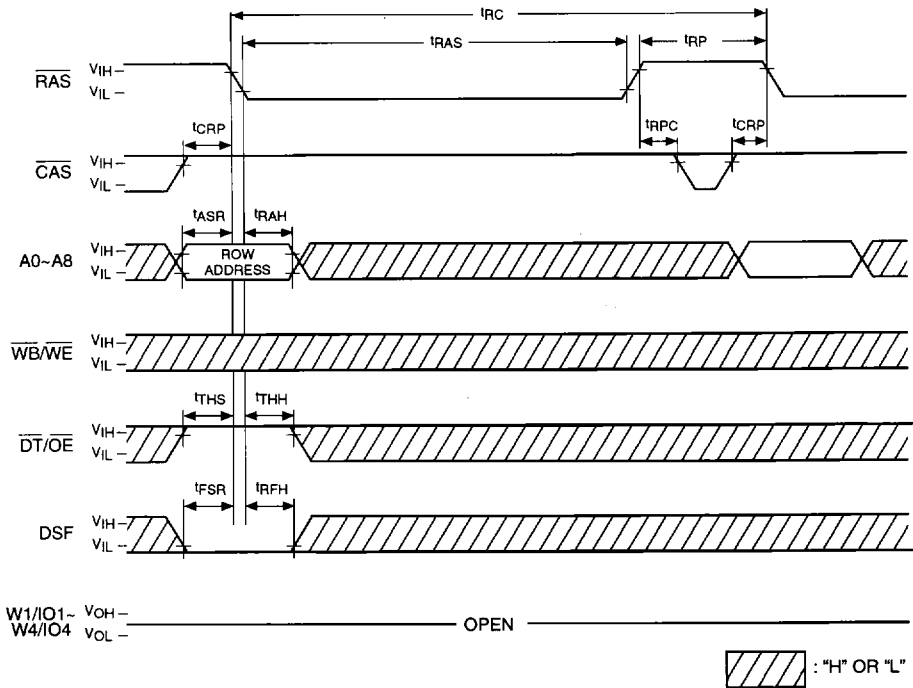

3

CAS before RAS Refresh Cycle

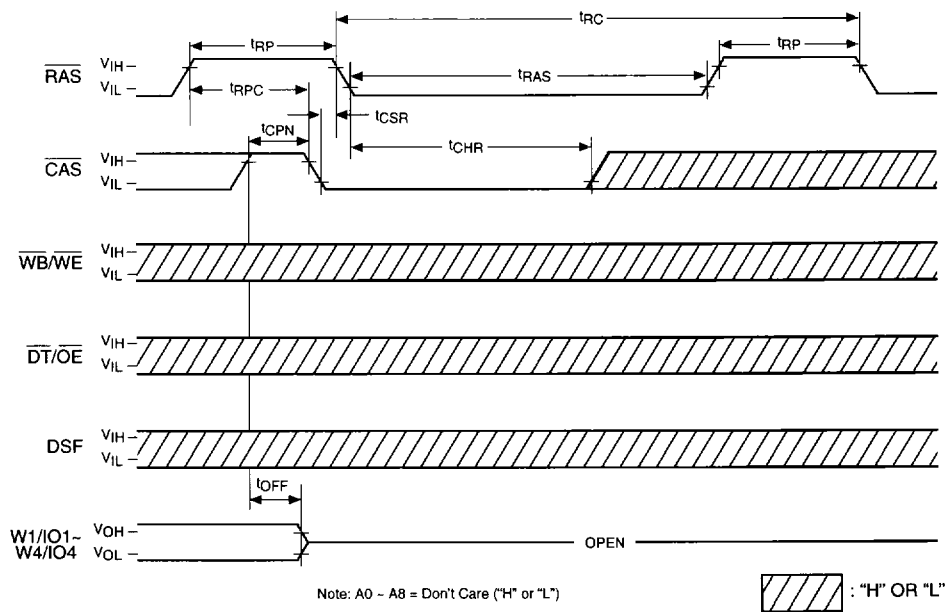

Flash Write Cycle

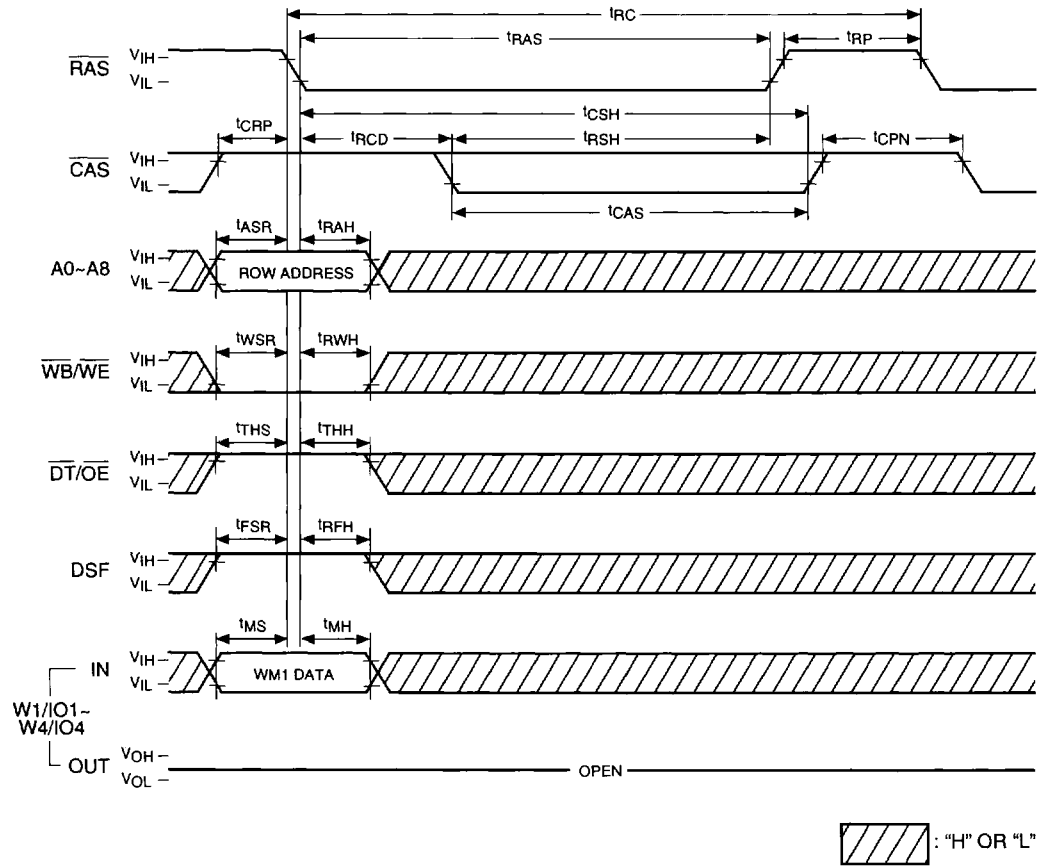

WM1 DATA	Cycle
0	Flash Write Disable
1	Flash Write Enable

Page Mode Block Write Cycle

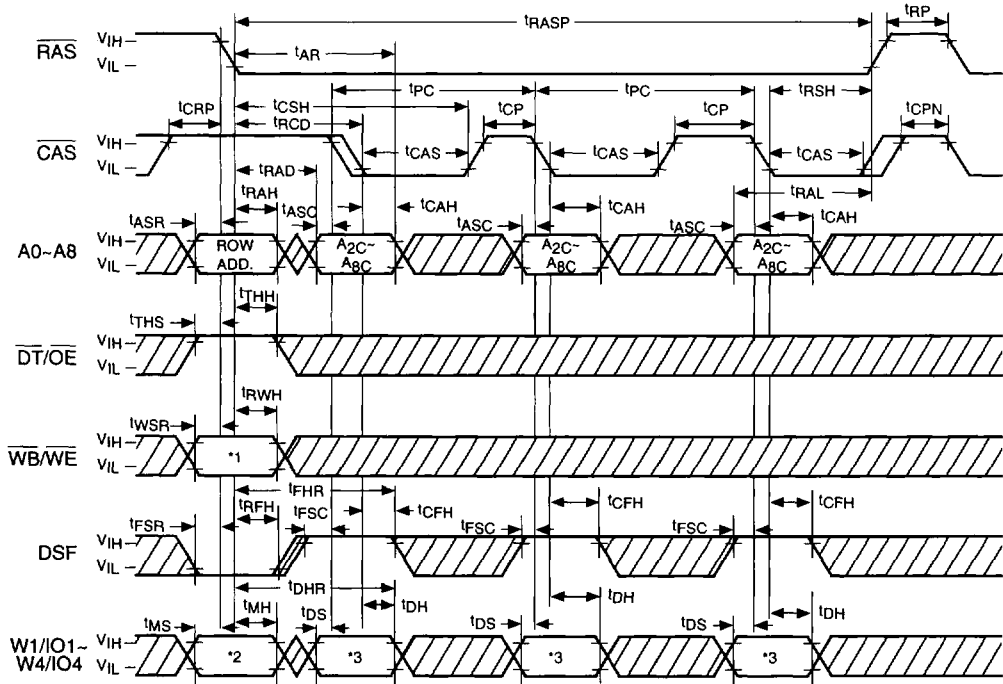

: "H" OR "L"

*1 $\overline{WB/WE}$	*2 W1/IO1-W4/IO4	Cycle
0	WM1 data	Masked Block Write
1	Don't Care	Block Write (Non Mask)

WM1 data: 0: Write Disable
1: Write Enable

*3) Column Select

$W1/IO1$ — Column 0 ($A_{1C} = 0, A_{0C} = 0$)
 $W2/IO2$ — Column 1 ($A_{1C} = 0, A_{0C} = 1$)
 $W3/IO3$ — Column 2 ($A_{1C} = 1, A_{0C} = 0$)
 $W4/IO4$ — Column 3 ($A_{1C} = 1, A_{0C} = 1$)

Wn/IO_n
 = 0 : Disable
 = 1 : Enable

Real Time Read Transfer Cycle

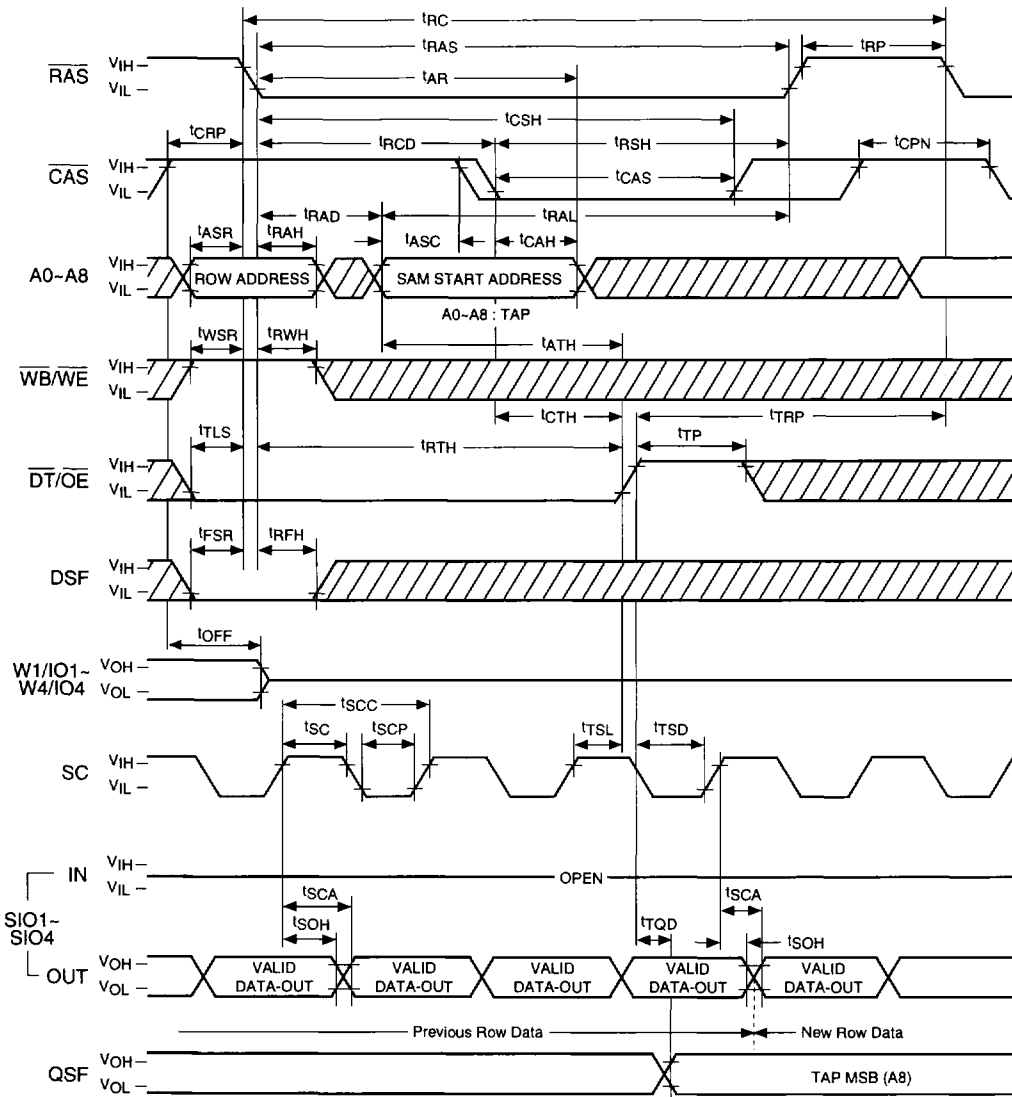

Note: SE = V_{IL}

 : "H" OR "L"

Split Read Transfer Cycle

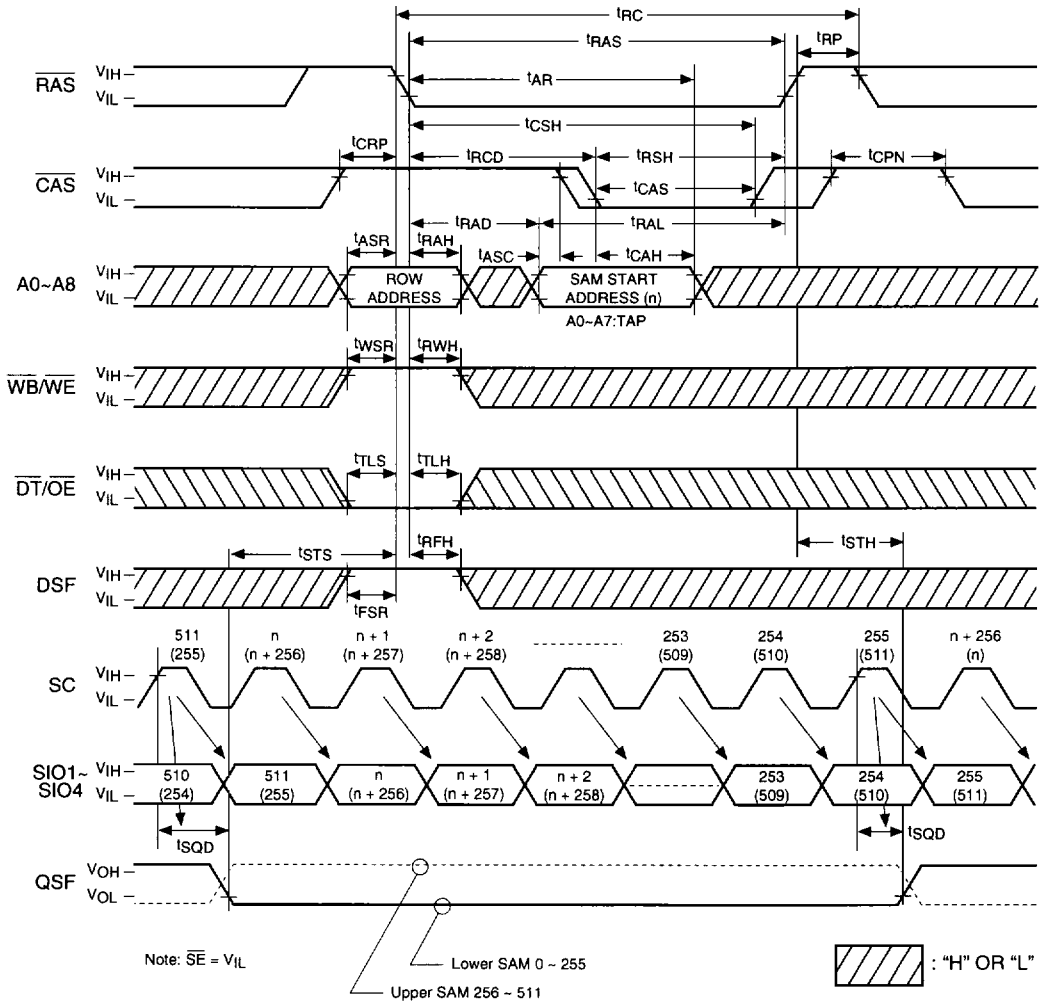

3

Pseudo Write Transfer Cycle

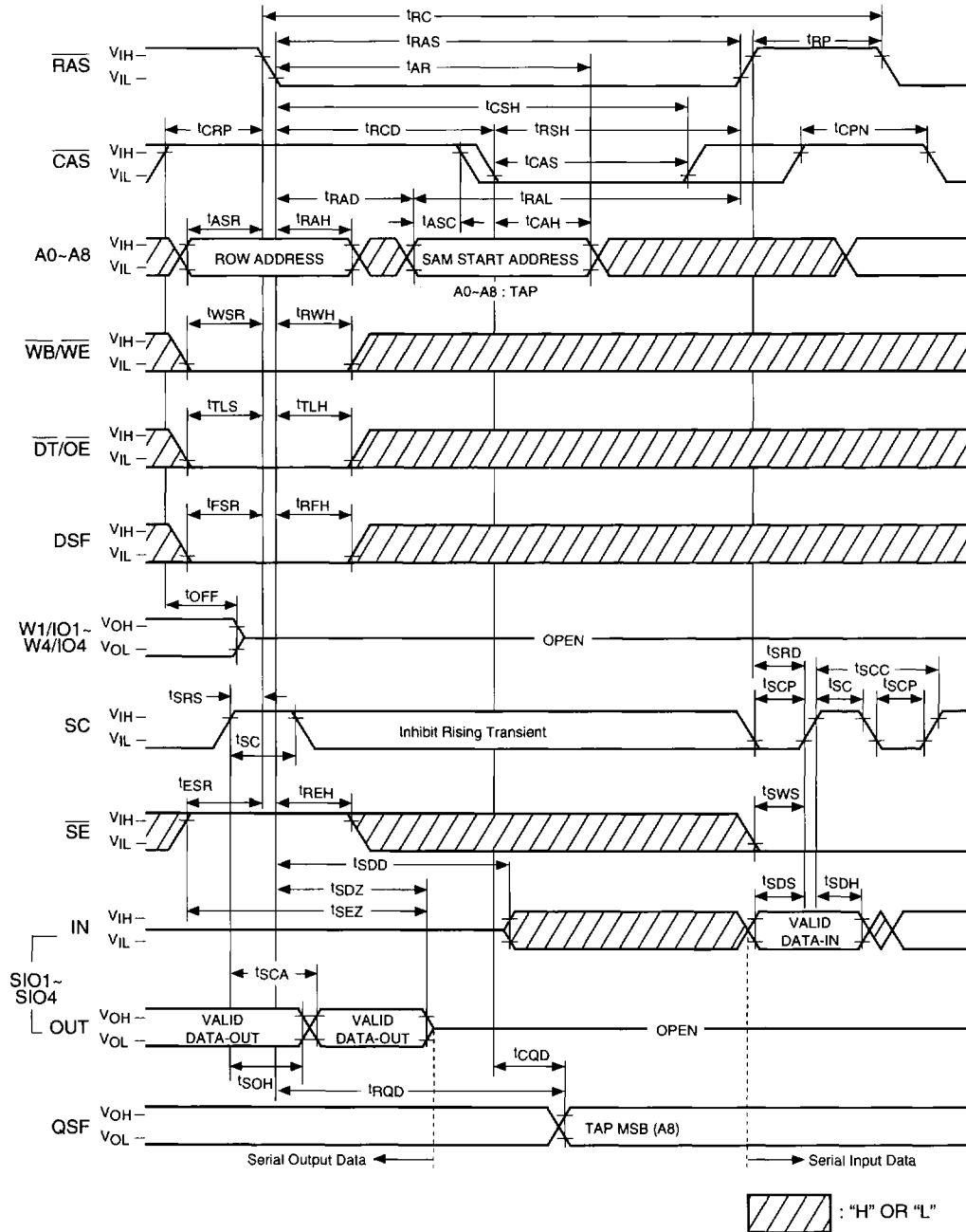

Write Transfer Cycle

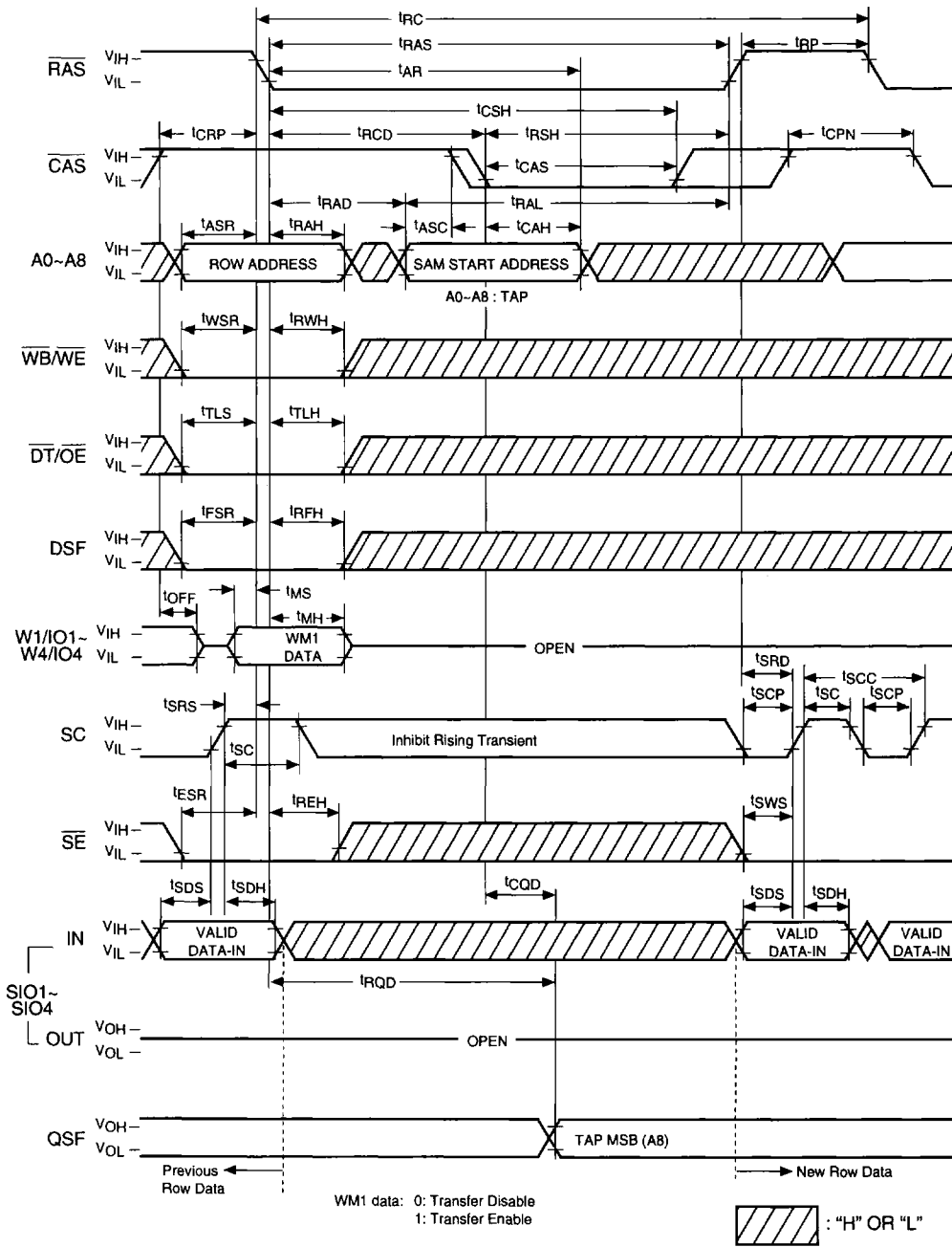

3

Split Write Transfer Cycle

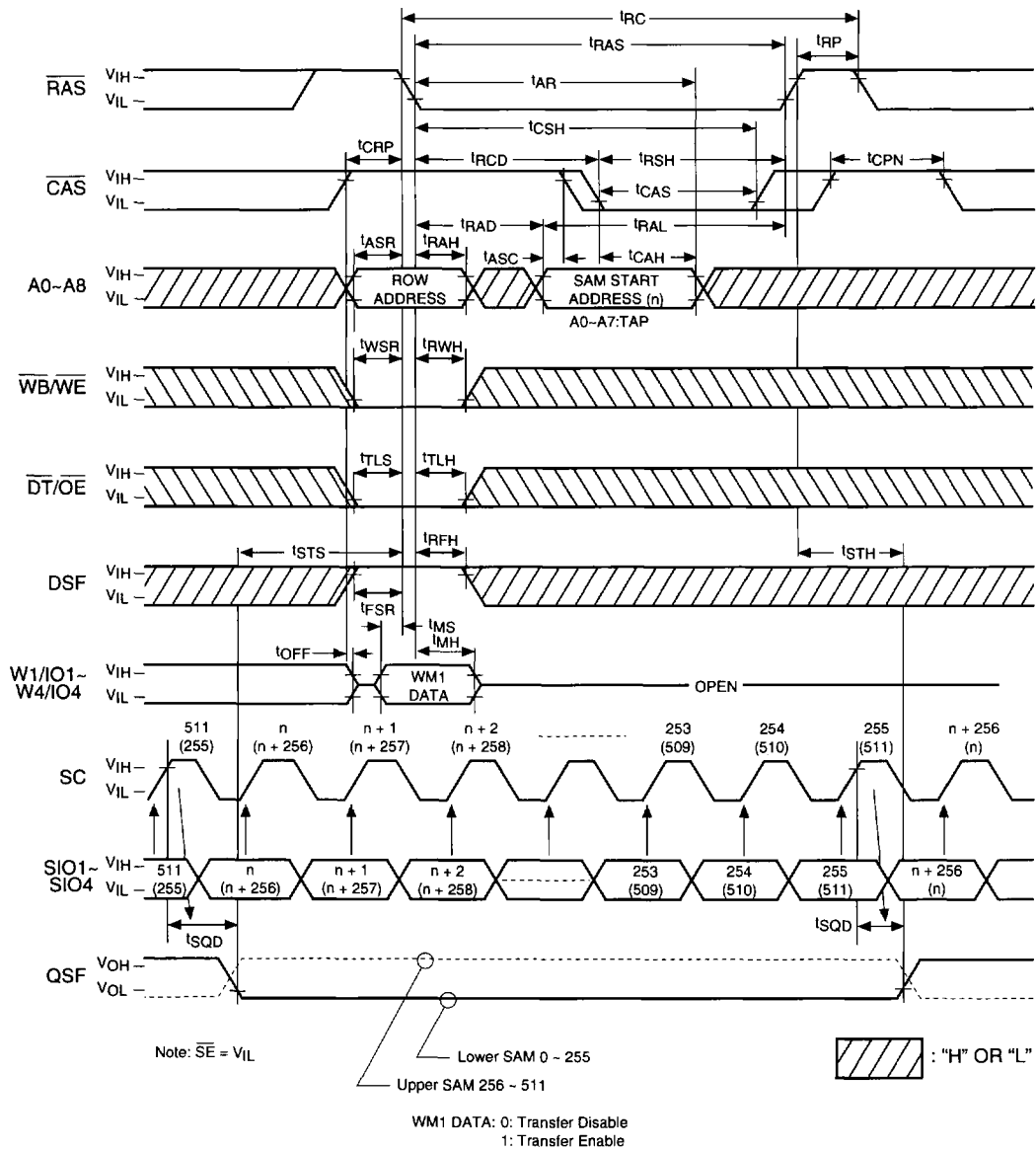

Serial Read Cycle ($\overline{SE} = V_{IL}$)

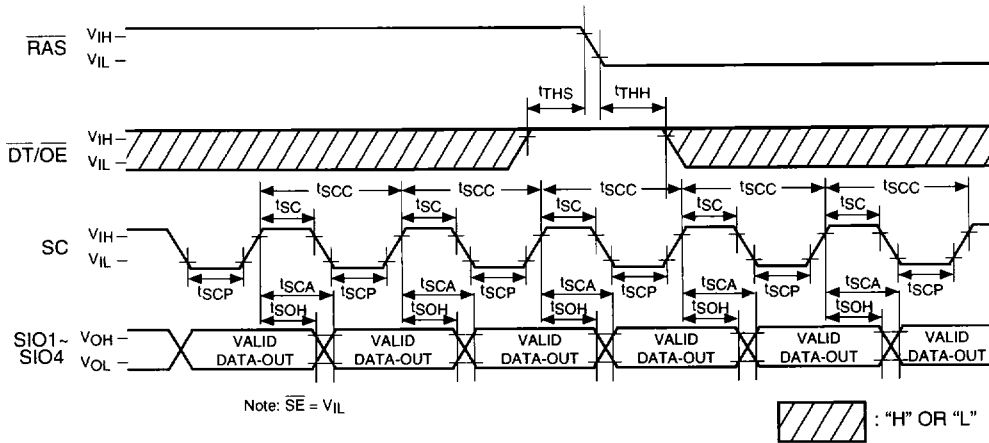

3

Serial Read Cycle (\overline{SE} Controlled Outputs)

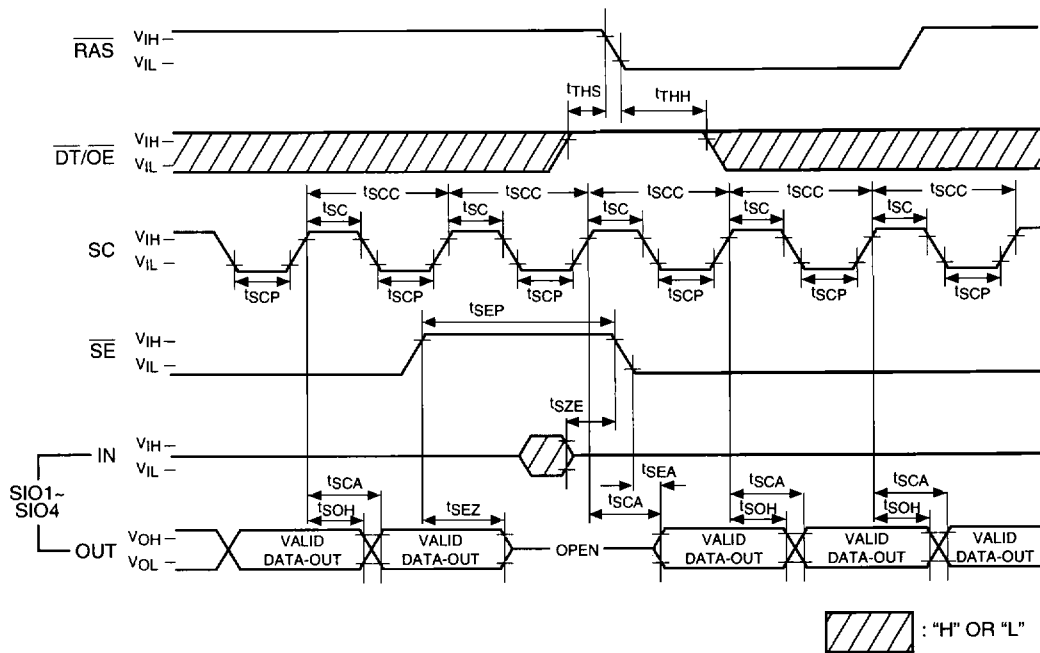

Pin Functions

Address Inputs: A0–A8

The 18 address bits required to decode 4 bits of the 1,048,576 cell locations within the dynamic RAM memory array of the V52C4258 are multiplexed onto 9 address input pins (A₀–A₈). Nine row address bits are latched on the falling edge of the row address strobe ($\overline{\text{RAS}}$) and the following nine column address bits are latched on the falling edge of the column address strobe ($\overline{\text{CAS}}$).

Row Address Strobe: $\overline{\text{RAS}}$

A random access cycle or a data transfer cycle begins at the falling edge of $\overline{\text{RAS}}$. $\overline{\text{RAS}}$ is the control input that latches the row address bits and the states of $\overline{\text{CAS}}$, $\overline{\text{DT/OE}}$, $\overline{\text{WB/WE}}$, $\overline{\text{SE}}$ and DSF to invoke the various random access and data transfer operating modes shown in Table 2. $\overline{\text{RAS}}$ has minimum and maximum pulse widths and a minimum precharge requirement which must be maintained for proper device operation and data integrity. The RAM port is placed in standby mode when the $\overline{\text{RAS}}$ control is held "high".

Column Address Strobe: $\overline{\text{CAS}}$

$\overline{\text{CAS}}$ is the control input that latches the column address bits and the state of the special function input DSF. DSF is used in conjunction with the $\overline{\text{RAS}}$ control to select either read/write operations or the special block write feature on the RAM port when the DSF input is held "low" at the falling edge of $\overline{\text{RAS}}$. Refer to the operation truth table shown in Table 1. $\overline{\text{CAS}}$ has minimum and maximum pulse widths and a minimum precharge requirement which must be maintained for proper device operation and data integrity. $\overline{\text{CAS}}$ also acts as an output enable for the output buffers on the RAM port.

Data Transfer/Output Enable: $\overline{\text{DT/OE}}$

The $\overline{\text{DT/OE}}$ input is a multifunction pin. When $\overline{\text{DT/OE}}$ is "high" at the falling edge of $\overline{\text{RAS}}$, RAM port operations are performed and $\overline{\text{DT/OE}}$ is used as an output enable control. When the $\overline{\text{DT/OE}}$ is "low" at the falling edge of $\overline{\text{RAS}}$, a data transfer operation is started between the RAM port and the SAM port.

Write Per Bit/Write Enable: $\overline{\text{WB/WE}}$

The $\overline{\text{WB/WE}}$ input is also a multifunction pin. When $\overline{\text{WB/WE}}$ is "high" at the falling edge of $\overline{\text{RAS}}$, during RAM port operations, it is used to write data into the memory array in the same manner as a standard DRAM. When $\overline{\text{WB/WE}}$ is "low" at the falling edge of $\overline{\text{RAS}}$, during RAM port operations, the write-per-bit function is enabled. The $\overline{\text{WB/WE}}$ input also

determines the direction of data transfer between the RAM array and the serial register (SAM).

When $\overline{\text{WB/WE}}$ is "high" at the falling edge of $\overline{\text{RAS}}$, the data is transferred from RAM to SAM (read transfer). When $\overline{\text{WB/WE}}$ is "low" at the falling edge of $\overline{\text{RAS}}$, the data is transferred from SAM to RAM (masked write transfer).

Write Mask Data/Data Input and Output:

W_1/IO_1 – W_4/IO_4

When the write-per-bit function is enabled, the mask data on the W_i/IO_i pins is latched into the write mask register (WM1) at the falling edge of $\overline{\text{RAS}}$. Data is written into the DRAM on data lines where the write-mask data is a logic "1". Writing is inhibited on data lines where the write-mask data is a logic "0". The write-mask data is valid for only one cycle. Data is written into the RAM port during a write or read-modify-write cycle. The input data is latched at the falling edge of either $\overline{\text{CAS}}$ or $\overline{\text{WB/WE}}$, whichever occurs late. During an early-write cycle, the outputs are in the high-impedance state. Data is read out of the RAM port during a read or read-modify-write cycle. The output data becomes valid on the W_i/IO_i pins after the specified access times from $\overline{\text{RAS}}$, $\overline{\text{CAS}}$, $\overline{\text{DT/OE}}$ and column address are satisfied and will remain valid as long as $\overline{\text{CAS}}$ and $\overline{\text{DT/OE}}$ are kept "low". The outputs will return to the high-impedance state at the rising edge of either $\overline{\text{CAS}}$ or $\overline{\text{DT/OE}}$, whichever occurs first.

Serial Clock: SC

All operations of the SAM port are synchronized with the serial clock SC. Data is shifted in or out of the SAM registers at the rising edge of SC. In a serial read, the output data becomes valid on the SIO pins after the maximum specified serial access time t_{SCA} from the rising edge of SC. The serial clock SC also increments the 9-bits serial pointer (8-bits in split register mode) which is used to select the SAM address. The pointer address is incremented in a wrap-around mode to select sequential locations after the starting location which is determined by the column address in the normal transfer cycle. When the pointer reaches the most significant address location (decimal 511), the next SC clock will place it at the least significant address location (decimal 0). The serial clock SC must be held at a constant V_{IH} or V_{IL} level during read/pseudo write/write transfer operations and should not be clocked while the SAM port is in the standby mode, to prevent the SAM pointer from being incremented.

Serial Enable: \overline{SE}

The \overline{SE} input is used to enable serial access operation. In a serial read cycle, \overline{SE} is used as an output control. In a serial write cycle, \overline{SE} is used as a write enable control. When \overline{SE} is "high", serial access is disabled, however, the serial address pointer location is still incremented when SC is clocked even when \overline{SE} is "high".

Special Function Control: DSF

The DSF input is latched at the falling edge of \overline{RAS} and \overline{CAS} and allows for the selection of various random port and data transfer operating modes. In addition to the conventional multiport DRAM, the special features, consisting of flash write, block write, load/read color register and split read/write transfer can be invoked.

Special Function Output: QSF

QSF is an output signal which, during split register mode, indicates which half of the split SAM is being accessed. QSF "low" indicates that the lower split SAM (Bit 0–255) is being accessed, and QSF "high" indicates that the upper split SAM (Bit 256–511) is being accessed. QSF is monitored so that after it toggles and after allowing for a delay of t_{STS} , split read/write transfer operation can be performed on the non-active split SAM.

Serial Input/Output: SIO1–SIO4

Serial input and output share common I/O pins. Serial input or output mode is determined by the most recent read, write or pseudo write transfer cycle. When a read transfer cycle is performed, the SAM port is in the output mode. When a write or pseudo write transfer cycle is performed, the SAM port is switched from output mode to input mode. During the subsequent write transfer cycle, the SAM remains in the input mode.

Operation Mode

The RAM port and data transfer operating of the V52C4258 are determined by the state of \overline{CAS} , $\overline{DT}/\overline{OE}$, $\overline{WB}/\overline{WE}$, \overline{SE} and DSF at the falling edge of \overline{RAS} and by the state of DSF at the falling edge of \overline{CAS} .

Table 1 and Table 2 show the operation truth table and the functional truth table for a listing of all available RAM port and transfer operations, respectively.

Table 1. Operation Truth Table

CAS Falling Edge ↓		DSF					
RAS Falling Edge ↓		DSF		0	0	1	1
CAS	$\overline{DT}/\overline{OE}$	$\overline{WB}/\overline{WE}$	\overline{SE}	0	1	0	1
0	•	•	•	CAS-before-RAS Refresh			
1	0	0	0	Masked Write Transfer	Split Write Transfer	Masked Write Transfer	Split Write Transfer with
1	0	0	1	Pseudo Write Transfer	With Mask	Pseudo Write Transfer	Mask
1	0	1	•	Read Transfer	Split Read Transfer	Read Transfer	Split Read Transfer
1	1	0	•	Read/Write per Bit	Masked Flash Write	Masked Block Write	Masked Flash Write
1	1	1	•	Read/Write	Load/Read Color	Block Write	Load/Read Color

Table 2. Functional Truth Table

Function	\overline{RAS} ↓					\overline{CAS} ↓	Address		W/IO			Write Mask	Register	
	\overline{CAS} ↓	DT/OE	WB/WE	DSF	SE	DSF	\overline{RAS} ↓	\overline{CAS} ↓	\overline{RAS} ↓	\overline{CAS} ↓	\overline{CAS} ↓ WE ↓		WM1	Color
CAS-before-RAS Refresh	0	•	•	•	•	–	•	–	•	–	–	–	–	–
Masked Write Transfer	1	0	0	0	0	•	Row	TAP	WM1	•	•	WM1	Load use	–
Pseudo Write Transfer	1	0	0	0	1	•	Row	TAP	•	•	•	–	–	–
Split Write Transfer	1	0	0	1	•	•	Row	TAP	WM1	–	•	WM1	Load use	–
Read Transfer	1	0	1	0	•	•	Row	TAP	•	•	•	–	–	–
Split Read Transfer	1	0	1	1	•	•	Row	TAP	•	•	•	–	–	–
Write per Bit	1	1	0	0	•	0	Row	Column	WM1	–	DIN	WM1	Load use	–
Masked Block Write	1	1	0	0	•	1	Row	Column A2C-8C	WM1	Column Select	–	WM1	Load use	use
Masked Flash Write	1	1	0	1	•	•	Row	•	WM1	–	•	WM1	Load use	use
Read/Write	1	1	1	0	•	0	Row	Column	•	–	DIN	–	–	–
Block Write	1	1	1	0	•	1	Row	Column A2C-8C	•	Column Select	–	–	–	use
Load/Read Color	1	1	1	1	•	•	Row	•	•	–	Color	–	–	Load/Read

Note: • = "0" or "1", TAP = SAM Start Address, – = not used.

If the special function control input (DSF) is in the "low" state at the falling edges of \overline{RAS} and \overline{CAS} , only the conventional multiport DRAM operating features can be invoked: \overline{CAS} -before- \overline{RAS} refresh, write transfer, pseudo-write transfer, read transfer, write-per-bit and read/write modes. If the DSF input

is "high" at the falling edge of \overline{RAS} , special features such as split write transfer, split read transfer, flash write and load/read color register can be invoked. If the DSF input is "low" at the falling edge of \overline{RAS} and "high" at the falling edge of \overline{CAS} , the block write special feature can be invoked.

3

RAM Port Operation

Fast Page Mode Cycle

Fast page mode allows data to be transferred into or out of multiple column locations of the same row by performing multiple $\overline{\text{CAS}}$ cycles during a single active $\overline{\text{RAS}}$ cycle. During a fast page cycle, the $\overline{\text{RAS}}$ signal may be maintained active for a period up to 100 μs . For the initial fast page mode access, the output data is valid after the specified access times from $\overline{\text{RAS}}$, $\overline{\text{CAS}}$, column address and $\overline{\text{DT/OE}}$. For all subsequent fast page mode read operations, the output data is valid after the specified access times from $\overline{\text{CAS}}$, column address and $\overline{\text{DT/OE}}$. When the write-per-bit function is enabled, the mask data latched at the falling edge of $\overline{\text{RAS}}$ is maintained throughout the fast page mode write or read-modify-write cycle.

$\overline{\text{RAS}}$ -Only Refresh

The data in the DRAM requires periodic refreshing to prevent data loss. Refreshing is accomplished by performing a memory cycle at each of the 512 rows in the DRAM array within the specified 8ms refresh period. Although any normal memory cycle will perform the refresh operation, this function is most easily accomplished with the " $\overline{\text{RAS}}$ -Only" cycle.

$\overline{\text{CAS}}$ -before- $\overline{\text{RAS}}$ Refresh

The V52C4258 also offer an internal-refresh function. When $\overline{\text{CAS}}$ is held "low" for a specified period (t_{CSR}) before $\overline{\text{RAS}}$ goes "low", an internal refresh address counter and on-chip refresh control clock generators are enabled and an internal refresh operation takes place. When the refresh operation is completed, the internal refresh address counter is automatically incremented in preparation for the next $\overline{\text{CAS}}$ -before- $\overline{\text{RAS}}$ cycle. For successive $\overline{\text{CAS}}$ -before- $\overline{\text{RAS}}$ refresh cycles, $\overline{\text{CAS}}$ can remain "low" while cycling $\overline{\text{RAS}}$.

Hidden Refresh

A hidden refresh is a $\overline{\text{CAS}}$ -before- $\overline{\text{RAS}}$ refresh performed by holding $\overline{\text{CAS}}$ "low" from a previous read cycle. This allows for the output data from the previous memory cycle to remain valid while performing a refresh. The internal refresh address counter provides the address and the refresh is accomplished by cycling $\overline{\text{RAS}}$ after the specified $\overline{\text{RAS}}$ -precharge period (refer to Figure 1.)

Write-Per-Bit Function

The write-per-bit function selectively controls the internal write-enable circuits of the RAM port. When $\overline{\text{WB/WE}}$ is held "low" at the falling edge of $\overline{\text{RAS}}$, during a random access operation, the write-mask is enabled. At the same time, the mask data on the W_i/IO_i pins is latched into the write-mask register (WM1). When a "0" is sensed on any of the W_i/IO_i pins, their corresponding write circuits are disabled and new data will not be written. When an "1" is sensed on any of the W_i/IO_i pins, their corresponding write circuits will remain enabled so that new data is written. The truth table of the write-per-bit function is shown in Table 3.

At the falling edge of $\overline{\text{RAS}}$				Function
$\overline{\text{CAS}}$	$\overline{\text{DT/OE}}$	$\overline{\text{WB/WE}}$	W_i/IO_i (i = 1-4)	
H	H	H	•	Write Enable
H	H	L	1	Write Enable
H	H	L	0	Write Mask

Table 3. Truth Table for Write-Per-Bit Function

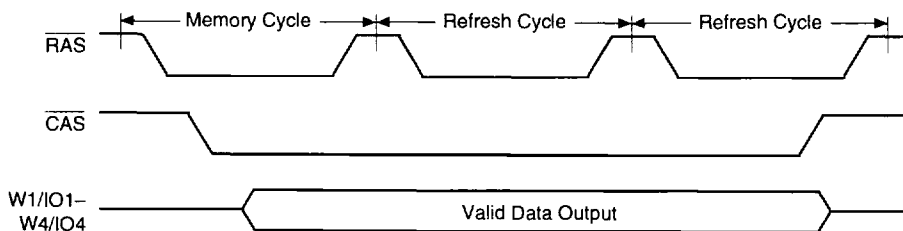

Figure 1. Hidden Refresh Cycle

An example of the write-per-bit function illustrating its application to displays is shown in Figures 2 and 3.

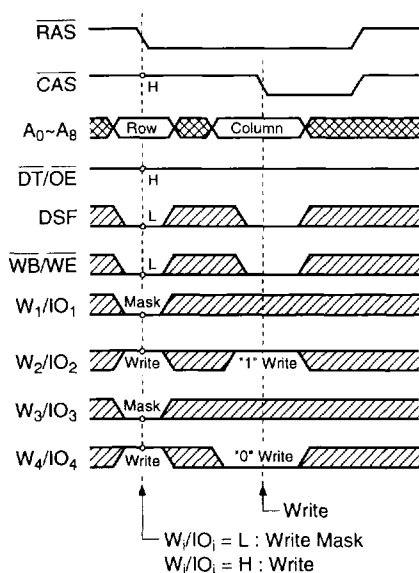

Figure 2. Write-per-bit timing cycle

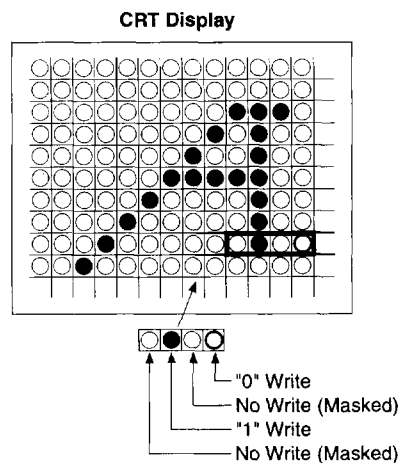

Figure 3. Corresponding bit-map

Load Color Register/Read Color Register

The V52C4258 is provided with an on-chip 4-bits register (color register) for use during the flash write or block write operation. Each bit of the color register corresponds to one of the DRAM I/O blocks. The load color register cycle is initiated by holding $\overline{\text{CAS}}$, $\overline{\text{WB/WE}}$, $\overline{\text{DT/OE}}$ and DSF "high" at the falling edge of $\overline{\text{RAS}}$. The data presented on the W_j/IO_j lines is subsequently latched into the color register at the falling edge of either $\overline{\text{CAS}}$ or $\overline{\text{WB/WE}}$, whichever occurs late. The data stored in the color register can be read out by performing a read color register cycle. This cycle is activated by holding $\overline{\text{CAS}}$, $\overline{\text{WB/WE}}$, $\overline{\text{DT/OE}}$ and DSF "high" at the falling edge of $\overline{\text{RAS}}$ and by holding $\overline{\text{WB/WE}}$ "high" at the falling edge of $\overline{\text{CAS}}$ and throughout the remainder of the cycle. The data in the color register becomes valid on the W_j/IO_j lines after the specified access times from $\overline{\text{RAS}}$ and $\overline{\text{DT/OE}}$ are satisfied. During the load/read color register cycle, valid A_0-A_8 row addresses are not required, but the memory cells on the row address latched at the falling edge of $\overline{\text{RAS}}$ are refreshed.

Flash Write

Flash write is a special RAM port write operation, which in a single $\overline{\text{RAS}}$ cycle allows for the data in the color register to be written into all the memory locations of a selected row. Each bit of the color register corresponds to one of the DRAM I/O blocks and the flash write operation can be selectively controlled on an I/O basis in the same manner as the write-per-bit operation.

A flash write cycle is performed by holding $\overline{\text{CAS}}$ "high", $\overline{\text{WB/WE}}$ "low" and DSF "high" at the falling edge of $\overline{\text{RAS}}$. The mask data must also be provided on the W_j/IO_j lines at the falling edge of $\overline{\text{RAS}}$ in order to enable the flash write operation for selected I/O blocks (refer to Figures 4 and 5).

Flash write is most effective for fast plane clear operations in frame buffer applications. Selected planes can be cleared by performing 512 flash write cycles and by specifying a different row address location during each flash write cycle (refer to Figure 6). Assuming a cycle time of 180ns, a plane clear operation can be completed in less than 92.2 μ s.

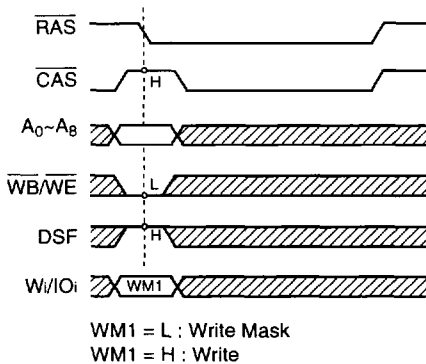

Figure 4. Flash Write Timing

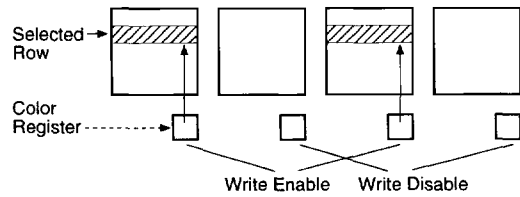

Figure 5. Flash Write

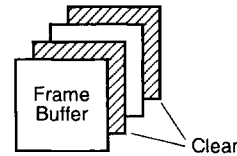

Figure 6. Plane clear application example

Block Write

Block write is also a special RAM port write operation which, in a single \overline{RAS} cycle, allows for the data in the color register to be written into 4 consecutive column address locations starting from a selected column address in a selected row. The block write operation can be selectively controlled on an I/O basis and a column mask capability is also available.

A block write cycle is performed by holding \overline{CAS} and $\overline{DT/OE}$ "high" and DSF "low" at the falling edge of \overline{RAS} and by holding DSF "high" at the falling edge of \overline{CAS} . The state of the $\overline{WB/WE}$ input at the falling edge of \overline{RAS} determines whether or not the I/O data mask is enabled ($\overline{WB/WE}$ must be "low" to enable the I/O data mask or "high" to disable it). At

the falling edge of \overline{RAS} , a valid row address and I/O mask data are also specified. At the falling edge of \overline{CAS} , the starting column address location and column mask data must be provided. During a block write cycle, the 2 least significant column address locations (A0C and A1C) are internally controlled and only the seven most significant column addresses (A2C–A8C) are latched at the falling edge of \overline{CAS} . (Refer to Figure 7.)

An example of the block write function is shown in Figure 8 with a data mask on W1/O1, W4/O4 and column 2. Block write is most effective for window clear and fill operations in frame buffer applications, as shown on Figure 9.

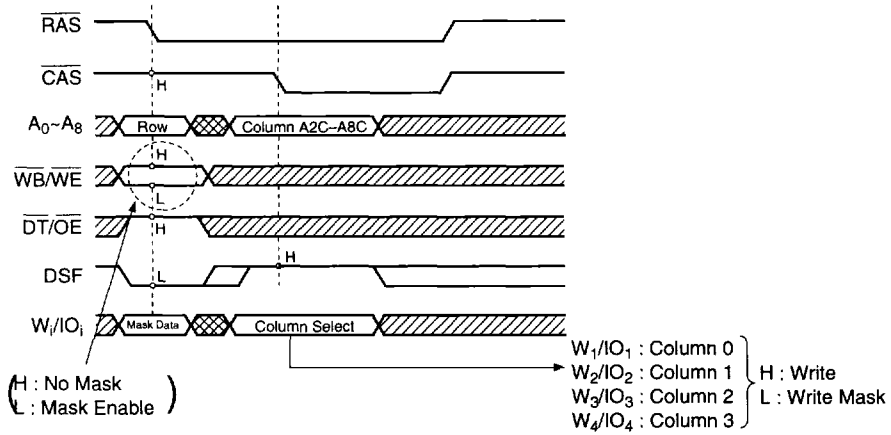

Figure 7. Block Write Timing

3

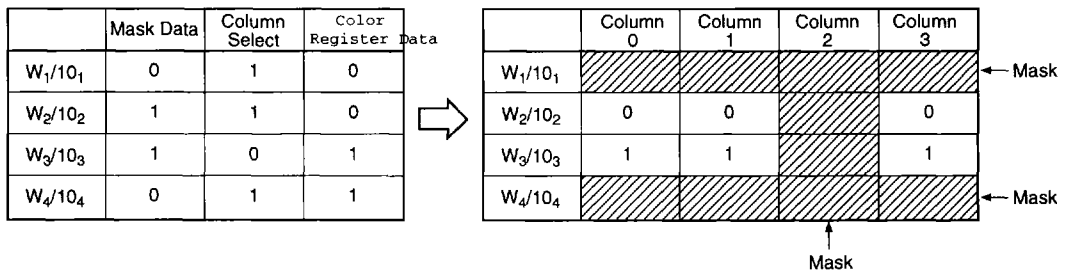

Figure 8. Example for Block Write

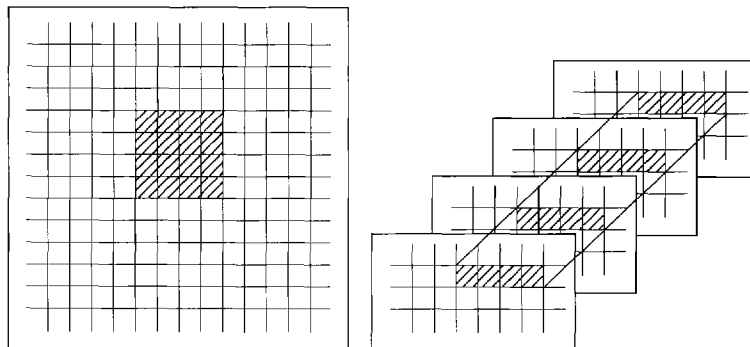

Figure 9. Example of Block Write Application

Fast Page Mode Block Write Cycle

Fast page mode block write can be used to perform high speed clear and fill operations. The cycle is initiated by holding the DSF signal "low" at the falling edge of \overline{RAS} and a fast page mode block write is performed during each subsequent \overline{CAS} cycle with DSF held "high" at the falling edge of \overline{CAS} .

If the DSF signal is "low" at the falling edge of \overline{CAS} , a normal fast page mode read/write operation will occur. Therefore, a combination of block write and read/write operations can be performed during a fast page mode block write cycle (refer to Figure 10).

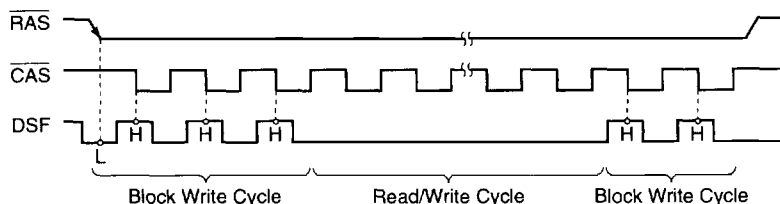

Figure 10. Fast Page Mode Block Write Cycle

SAM Port Operation

The V52C4258 is provided with a 512 words by 4 bits serial access memory (SAM) which can be operated in the single register mode or in the split register mode.

Single Register Mode

When operating in the single register mode, high speed serial read or write operations can be performed through the SAM port independent of the RAM port operations, except during read/write/pseudo-write transfer cycles. The preceding transfer operation determines the direction of data flow through the SAM port. If the preceding transfer operation is a read transfer, the SAM port is in the output mode. If the preceding transfer operation is a

write or pseudo write transfer, the SAM port is in the input mode. The pseudo write transfer operation only switches the SAM port from output mode to input mode; data is not transferred from SAM to RAM.

Serial data can be read out of the SAM port after a read transfer (RAM → SAM) has been performed. The data is shifted out of the SAM port starting at any of the 512 bits locations. The TAP location corresponds to the column address selected at the falling edge of \overline{CAS} during the read transfer cycle. The SAM registers are configured as circular data registers. The data is shifted out sequentially starting from the selected tap location to the most significant bit, and then wraps around to the least significant bit, as illustrated below.

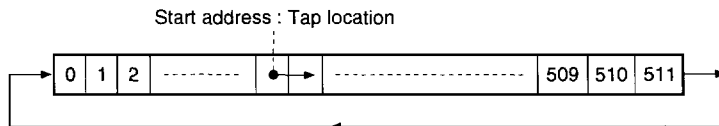

Subsequent real-time read transfer may be performed on-the-fly as many times as desired, within the refresh constraints of the DRAM array. Simultaneous serial read operation can be performed with some timing restrictions. A pseudo write transfer cycle is performed to change the SAM port from output mode to input mode, in order to write data into the serial registers through the SAM

port. A write transfer cycle must be used subsequently to load the SAM data into the RAM row selected by the row address at the falling edge of \overline{RAS} . The starting location in the SAM registers for the next serial write is selected by the column address at the falling edge of \overline{CAS} . The truth table for single register mode SAM operation is shown in Table 4.

SAM Port Operation	$\overline{DT}/\overline{OE}$ at the falling edge of \overline{RAS}	SC	\overline{SE}	Function	Preceded by a
Serial Output Mode	H		L	Enable Serial Read	Read Transfer
			H	Disable Serial Read	
Serial Input Mode	H		L	Enable Serial Write	Write Transfer
			H	Disable Serial Write	
Serial Input Mode	H		L	Enable Serial Write	Pseudo Write Transfer
			H	Disable Serial Write	

Table 4. Truth Table for SAM Port Operation

3

Split Register Mode

In split register mode, data can be shifted into or out of one half of the SAM while a split read or split write transfer is being performed on the other half of the SAM. A normal (non-split) read/write/pseudo write transfer operation must precede any split read/write transfer operation. The non-split read, write and pseudo write transfers will set the SAM port into output mode or input mode. The split read and write transfers will not change the SAM port mode set by the preceding normal transfer operation. RAM port operation may be performed independently except during split transfers. In the

split register mode, serial data can be shifted in or out of one of the split SAM registers starting from any of the 256 tap locations, excluding the last address of each split SAM. Data is shifted in or out sequentially starting from the selected tap location to the most significant bit (255 or 511) of the first split SAM. Then the SAM pointer moves to the tap location selected for the second split SAM, to shift data in or out sequentially starting from this tap location to the most significant bit (511 or 255), and finally wraps around to the least significant bit, as illustrated below.

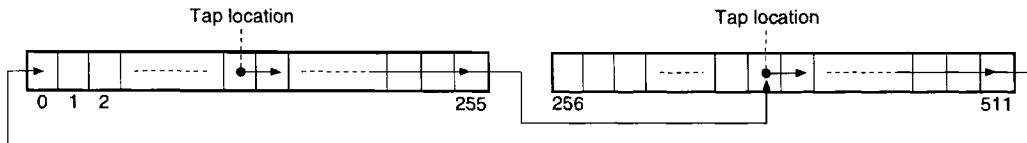

Refresh

The SAM data registers are static flip-flop, therefore a refresh is not required.

Data Transfer Operation

The V52C4258 features two types of internal bidirectional data transfer capability between RAM and the SAM, as shown in Figure 11. During a normal transfer, 512 words by 4 bits of data can be

loaded from RAM to SAM (Read Transfer) or from SAM to RAM (Write Transfer). During a split transfer, 256 words by 4 bits of data can be loaded from the lower/upper half of the RAM into the lower/upper half of the SAM (Split Read Transfer) or from the lower/upper half of the SAM into the lower/upper half of the RAM (Split Write Transfer). The normal transfer and split transfer modes are controlled by the DSF special function input signal.

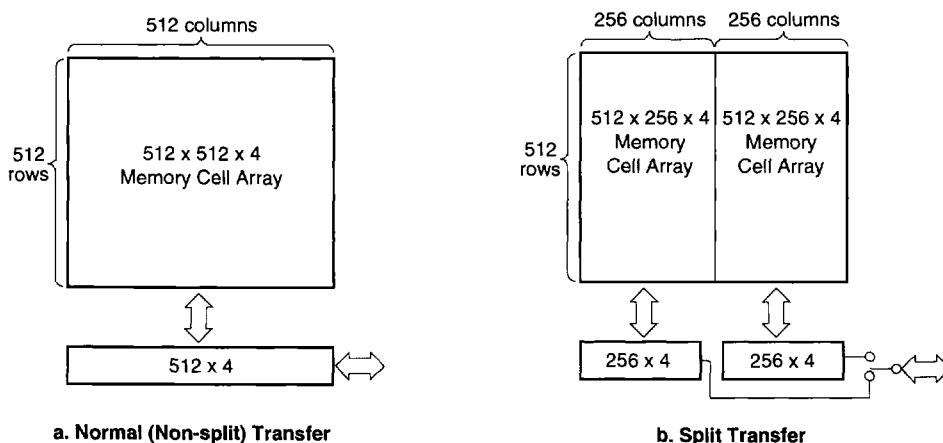

Figure 11. Transfer Operation

As shown in Table 5, the V52C4258 supports five types of transfer operations: read transfer, split read transfer, write transfer, split write transfer, and pseudo write transfer. Data transfer operations between RAM and SAM are invoked by holding the DT/OE signal "low" at the falling edge of \overline{RAS} . The type of data transfer operation is determined by the state of \overline{CAS} , $\overline{WB/WE}$, \overline{SE} and DSF which are latched at the falling edge of \overline{RAS} . During normal data transfer operations, the SAM port is switched from input to output mode (Read Transfer) or output to input mode (Write Transfer/Pseudo Write Transfer), whereas it remains unchanged during split transfer operations (Split Read or Split Write

Transfer). During a data transfer cycle, the row address A_0-A_8 selects one of the 512 rows of the memory array to or from which data will be transferred, and the column address A_0-A_8 selects one of the tap locations in the serial register. The selected tap location is the start position in the SAM port from which the first serial data will be read out during the subsequent serial read cycle or the start position in the SAM port into which the first serial data will be written during the subsequent serial write cycle. During split data transfer cycles, the most significant column address (ABC) is controlled internally to determine which half of the serial register will be accessed.

At the falling edge of \overline{RAS}					Transfer Mode	Transfer Direction	Transfer Bit	SAM Port Mode
CAS	$\overline{DT/OE}$	$\overline{WB/WE}$	SE	DSF				
H	L	H	•	L	Read Transfer	RAM → SAM	512 x 4	Input → Output
H	L	L	L	L	Write Transfer	SAM → RAM	512 x 4	Output → Input
H	L	L	H	L	Pseudo Write Transfer	—	—	Output → Input
H	L	H	•	H	Split Read Transfer	RAM → SAM	256 x 4	Not changed
H	L	L	•	H	Split Write Transfer	SAM → RAM	256 x 4	Not changed

Note: • = "H" or "L"

Table 5. Transfer Modes

Read Transfer Cycle

A read transfer cycle consists of loading a selected row of data from the RAM array into the SAM register. A read transfer is invoked by holding \overline{CAS} "high", $\overline{DT/OE}$ "low", $\overline{WB/WE}$ "high" and DSF "low" at the falling edge of \overline{RAS} . The row address selected at the falling edge of \overline{RAS} determines the RAM row to be transferred into the SAM. The transfer cycle is completed at the rising edge of $\overline{DT/OE}$. When the transfer is completed, the SAM port is set into the output mode. In a read/real time transfer cycle, the transfer of a new row of data is completed at the rising edge of $\overline{DT/OE}$ and this data becomes valid on the SIO lines after the

specified access time (t_{SCA}) from the rising edge of the subsequent serial clock (SC) cycle. The start address of the serial pointer of the SAM is determined by the column address selected at the falling edge of \overline{CAS} .

Figure 12 shows the operation block diagram for the read transfer operation.

In a read transfer cycle (which is preceded by a write transfer cycle), the SC clock must be held at a constant V_{IL} or V_{IH} , after the SC high time has been satisfied. A rising edge of the SC clock must not occur until after the specified delay (t_{TSD}) from the rising edge of $\overline{DT/OE}$, as shown in Figure 13.

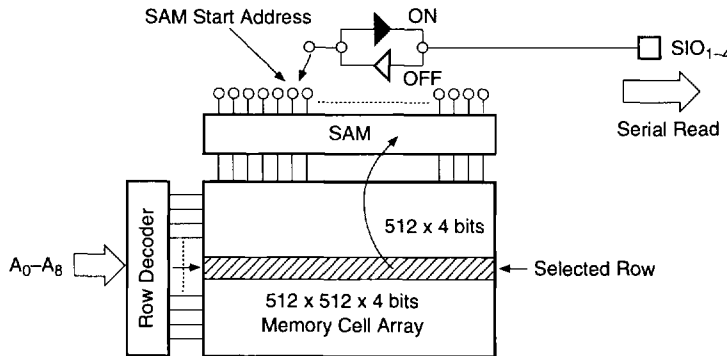

Figure 12. Block Diagram for Read Transfer Operation

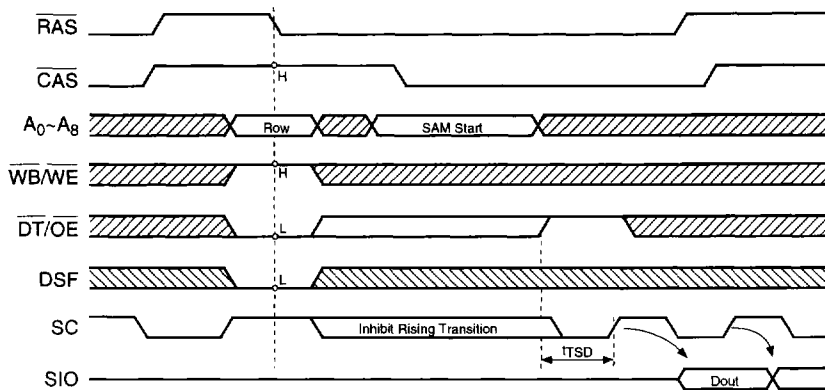

Figure 13. Read Transfer Timing

In a real time read transfer cycle (which is preceded by another read transfer cycle), the previous row data appears on the SIO lines until the $\overline{DT}/\overline{OE}$ signal goes "high" and the serial access time (t_{SCA}) for the following serial clock is satisfied. This feature allows for the first bit of the new row of data to appear on the serial output as soon as the last bit of the previous row has been strobed without any timing loss. To make this continuous data flow possible, the rising edge of $\overline{DT}/\overline{OE}$ must be synchronized with \overline{RAS} , \overline{CAS} and the subsequent rising edge of SC (t_{RTH} , t_{CTH} , and t_{TSL}/t_{TSD} must be satisfied), as shown in Figure 14.

The timing restrictions t_{TSL}/t_{TSD} are 5ns min/15ns min. The split read transfer mode eliminates these timing restrictions.

Write Transfer Cycle

A write transfer cycle consists of loading the contents of the SAM register into a selected row of the RAM array. If the SAM data to be transferred must first be loaded through the SAM port, a pseudo write transfer operation must precede the write transfer cycles. However, if the SAM port data to be transferred into the RAM was previously loaded into the SAM via a read transfer, the SAM to RAM transfer can be executed simply by performing a write transfer directly. A write transfer is invoked by holding \overline{CAS} "high", $\overline{DT}/\overline{OE}$ "low", $\overline{WB}/\overline{WE}$ "low", \overline{SE} "low" and DSF "low" at the falling edge of \overline{RAS} . This write transfer is selectively controlled per RAM I/O block by setting the mask data on the W/IO_i lines at the falling edge of \overline{RAS} (same as in the write-per-bit operation). Figures 15 and 16 show the timing diagram and block diagram for write transfer operations, respectively.

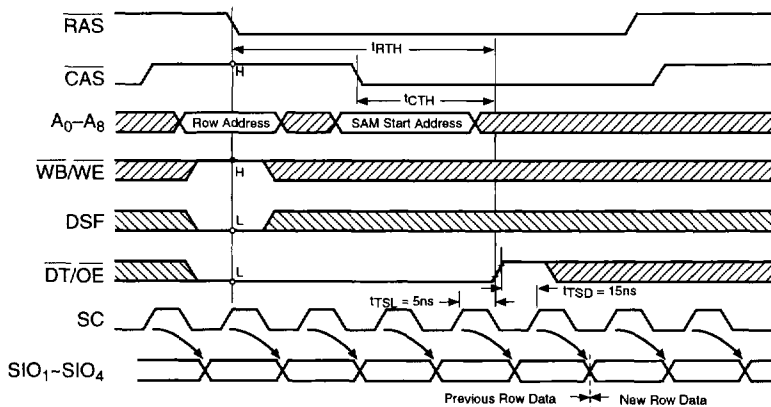

Figure 14. Real Time Read Transfer

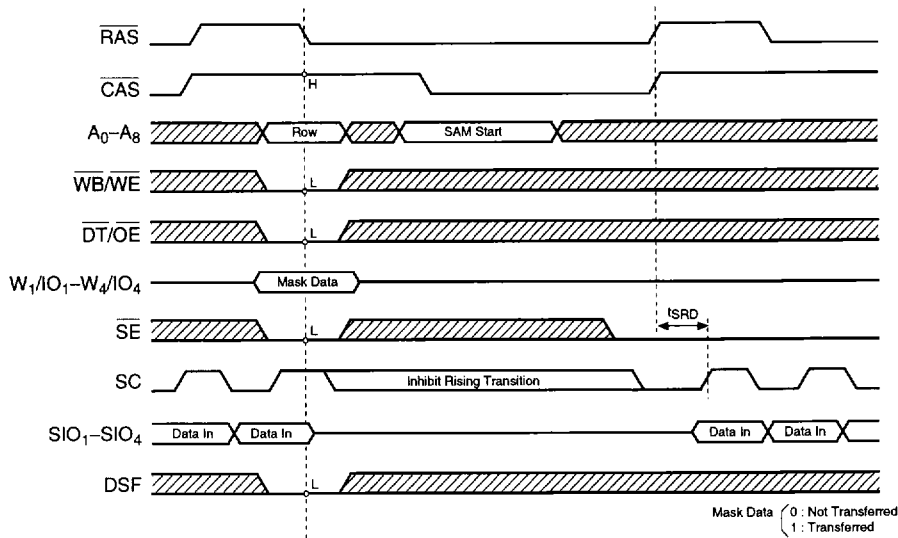

Figure 15. Write Transfer Timing

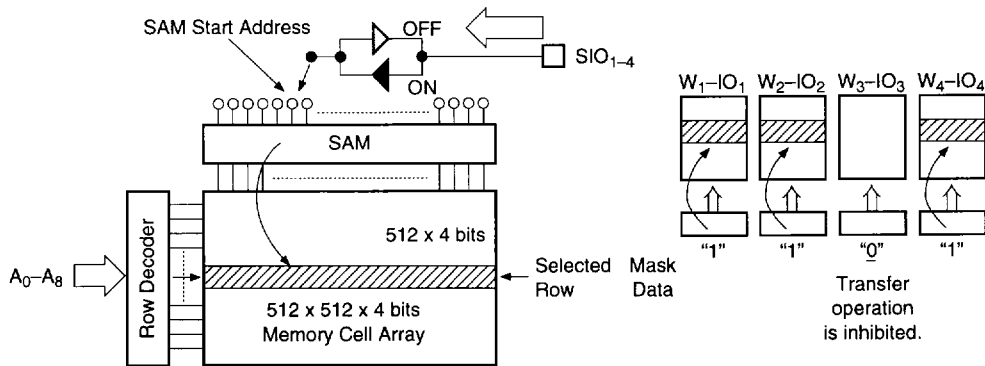

Figure 16. Block Diagram for Write Transfer Operation

The row address selected at the falling edge of \overline{RAS} determines the RAM row address into which the data will be transferred. The column address selected at the falling edge of \overline{CAS} determines the start address of the serial pointer of the SAM. After the write transfer is completed, the SIO lines are set in the input mode so that serial data synchronized with the SC clock can be loaded.

When consecutive write transfer operations are performed, new data must not be written into the serial register until the \overline{RAS} cycle of the preceding write transfer is completed. Consequently, the SC clock must be held at a constant V_{IL} or V_{IH} during the \overline{RAS} cycle. A rising edge of the SC clock is only allowed after the specified delay (t_{SRD}) from the rising edge of \overline{RAS} , at which time a new row of data can be written in the serial register.

Pseudo Write Transfer Cycle

A pseudo write transfer cycle must be performed before loading data into the serial register after a read transfer operation has been executed. The only purpose of a pseudo write transfer is to change the SAM port mode from output mode to input mode (a data transfer from SAM to RAM does not occur). After the serial register is loaded with new data, a write transfer cycle must be performed to transfer the data from SAM to RAM. A pseudo write transfer is invoked by holding \overline{CAS} "high", $\overline{DT/OE}$ "low", $\overline{WB}/\overline{WE}$ "low", \overline{SE} "high" and DSF "low" at the falling edge of \overline{RAS} . The timing conditions are the same as the one for the write transfer cycle except for the state of \overline{SE} at the falling edge of \overline{RAS} .

Split Data Transfer and QSF

The V52C4258 features a bidirectional split data transfer capability between the RAM and the SAM. During split data transfer operation, the serial register is split into two halves which can be controlled independently. Split read or split write transfer operations can be performed to or from one half of the serial register while serial data can be shifted into or out of the other half of the serial register, as shown in Figure 17. The most significant column address location (A8C) is controlled internally to determine which half of the serial register will be accessed. QSF is an output which indicates which half of the serial register is in an active state. QSF changes state when the last SC clock is applied to active split SAM, as shown in Figure 18.

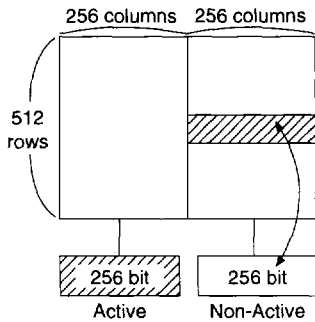

Active SAM	QSF Level
lower SAM	"Low"
upper SAM	"High"

Figure 17. Split Register Mode

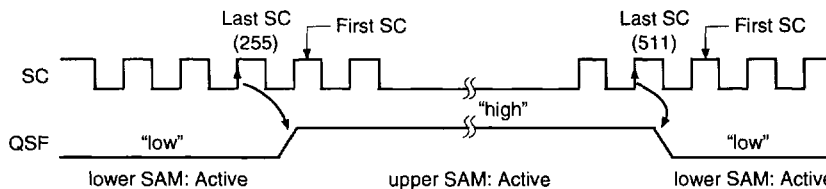

Figure 18. QSF Output State During Split Register Mode

Split Read Transfer Cycle

A split read transfer consists of loading 256 words by 4 bits of data from a selected row of the split RAM array into the corresponding non-active split SAM register.

Serial data can be shifted out of the other half of the split SAM register simultaneously. The block diagram and timing diagram for split read transfer mode are shown in Figures 19 and 20, respectively. During split read transfer operation, the RAM port

input clocks do not have to be synchronized with the serial clock SC, thus eliminating timing restrictions as in the case of on-the-fly read transfers. A split read transfer can be performed after a delay of t_{STS} from the change of state of the QSF output is satisfied.

A normal (non-split) read transfer operation must precede split read transfer cycles as shown in the example in Figure 21.

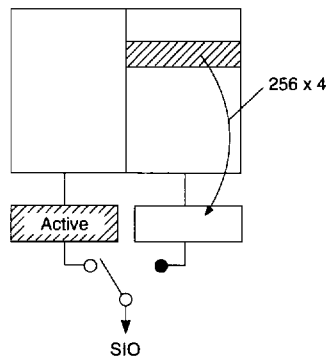

Figure 19. Block Diagram for Split Read Transfer

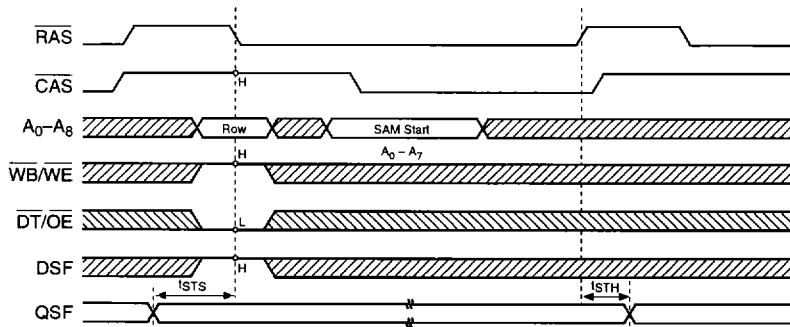

Figure 20. Timing Diagram for Split Read Transfer

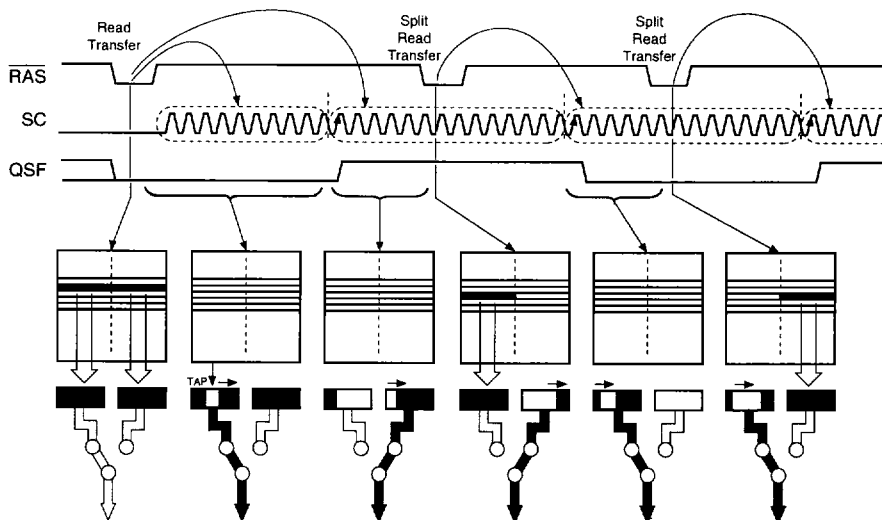

Figure 21. Example of Consecutive Read Transfer Operations

Split Write Transfer Cycle

A split write transfer cycle consists of loading 256 words by 4 bits of data from the non-active split SAM register into a selected row of the corresponding split RAM array.

Serial data can be shifted into the other half of the split SAM register simultaneously. The block diagram and timing diagram for split write transfer mode are shown in Figures 22 and 23, respectively. During split write transfer operation, the RAM port input clocks do not have to be synchronized with the serial clock SC, thus allowing for real time transfer. A split write transfer can be performed after a delay of t_{STS} from the change of state of the QSF output is satisfied.

A pseudo write transfer operation must precede split transfer cycles as shown in Figure 24. The purpose of the pseudo write transfer operation is to

switch the SAM port from output mode to input mode and to set the initial tap location prior to split write transfer operations.

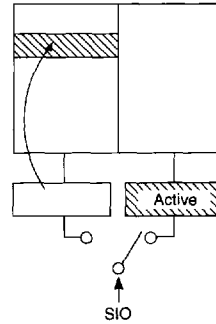

Figure 22. Block Diagram for Split Write Transfer

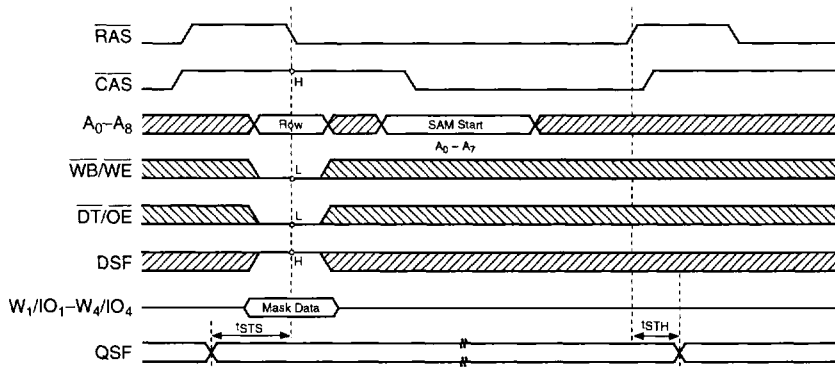

Figure 23. Timing Diagram for Split Write Transfer

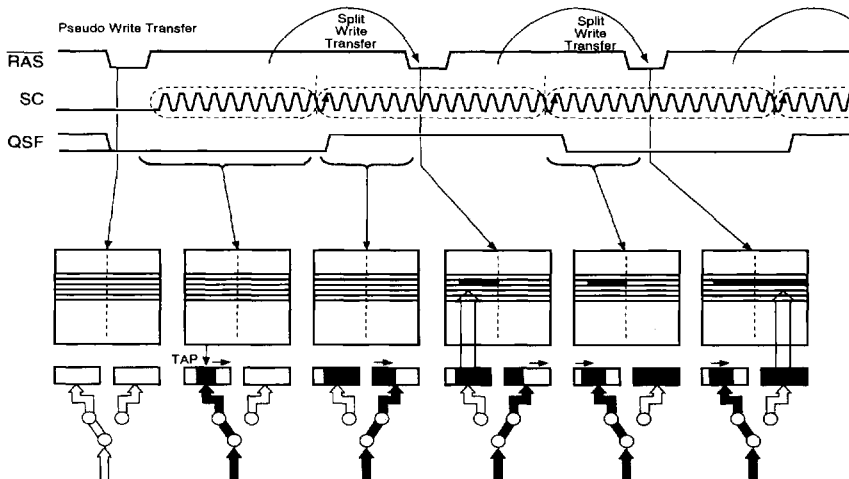

Figure 24. Example of Consecutive Write Transfer Operations

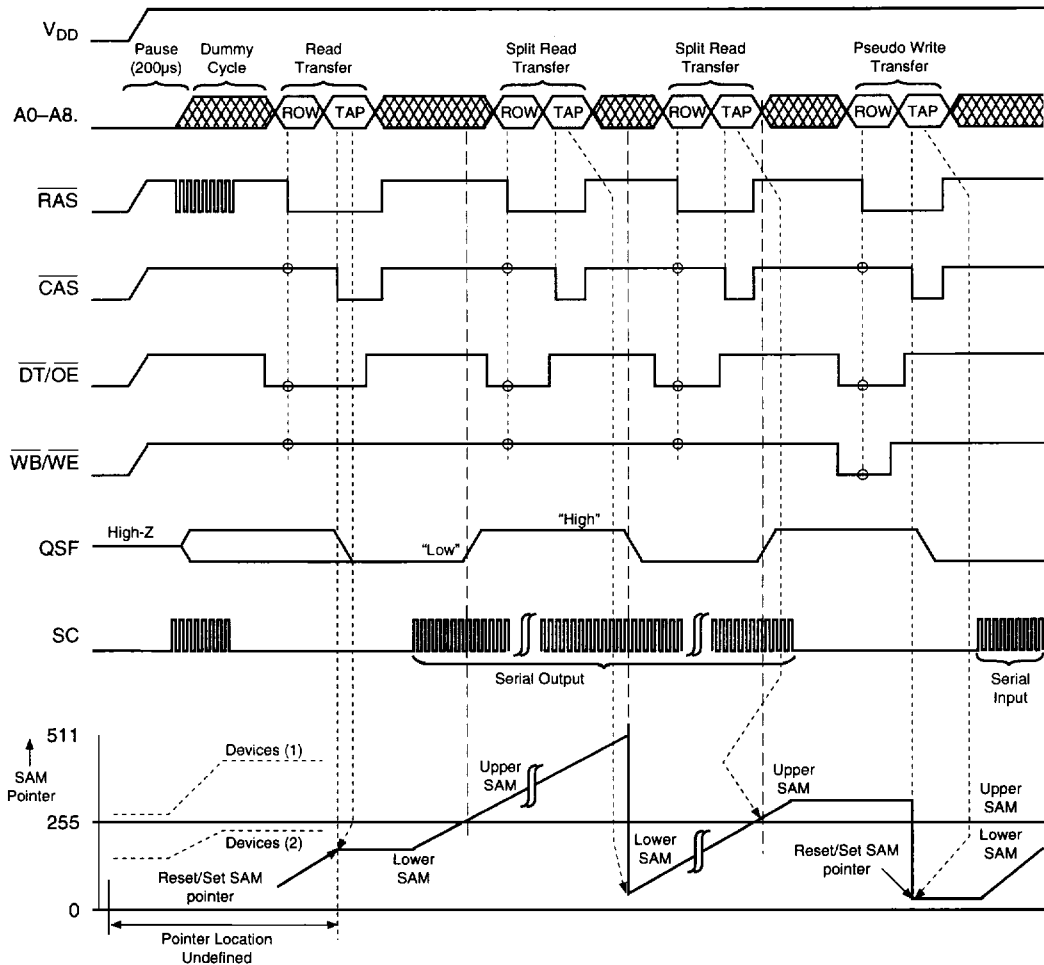

Figure 25. Example of Split SAM Register Operation Sequence

Split-Register Operation Sequence - Example

Split read/write transfers must be preceded by a normal (non-split) transfer, such as a read, write or pseudo write transfer. Figure 25 illustrates an example of split register operation sequence after device power-up and initialization. After power-up, a minimum of 8 \overline{RAS} and 8 SC clock cycles must be performed to properly initialize the device. A read transfer is then performed and the column address latched at the falling edge of \overline{CAS} sets the SAM tap pointer location, which up to that point was in an undefined location. Subsequently, the pointer

address is incremented by cycling the serial clock SC from the starting location to the last location in the register (address 511), and wraps around to the tap location set by the split read transfer performed for the lower SAM while the upper SAM is being accessed. The SAM address is incremented as long as SC is clocked. The following split read transfer sets a new tap location in the upper split SAM register (address 256 in this example), and the pointer is incremented from this location by cycling the SC clock.

The next operation is a pseudo write transfer which switches the SAM port from output mode to input mode in preparation for either write transfers or split write transfers. The column address latched at the falling edge of $\overline{\text{CAS}}$ during the pseudo write transfer sets the serial register tap location. Serial data will be written into the SAM starting from this location.

Transfer Operation Without $\overline{\text{CAS}}$

During all transfer cycles, the $\overline{\text{CAS}}$ input clock must be cycled, so that the column addresses are latched at the falling edge of $\overline{\text{CAS}}$, to set the SAM tap location. If $\overline{\text{CAS}}$ was maintained at a constant "high" level during a transfer cycle, the SAM pointer location would be undefined. Therefore, a transfer cycle with $\overline{\text{CAS}}$ held "high" is not allowed (refer to the illustration below).

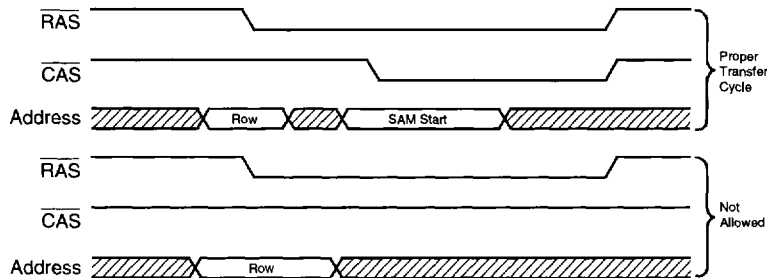

Tap Location Selection in Split Transfer Operation

a. In a split transfer operation, column addresses A0C through A7C must be latched at the falling edge of $\overline{\text{CAS}}$ in order to set the tap location in one of the split SAM registers. During a split transfer, column address A8C is controlled internally and

therefore it is ignored internally at the falling edge of $\overline{\text{CAS}}$. During a split transfer, it is not allowed to set the last address location (A0C–A7C = FF), in either the lower SAM or the upper SAM, as the tap location.

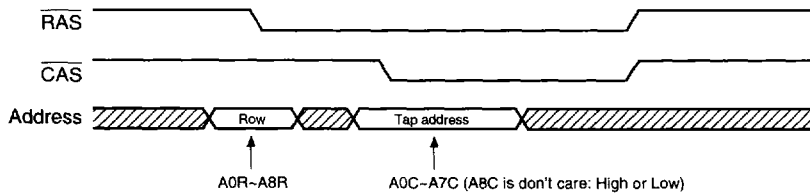

b. In the case of multiple split transfers performed into the same split SAM register, the tap location specified during the last split transfer, before QSF toggles, will prevail. In the example shown below, multiple split transfers are performed into the

upper SAM (non-active) while the lower SAM (active) is being accessed at the time when QSF toggles, the first SC serial clock will start shifting serial data starting from the Tap N address location.

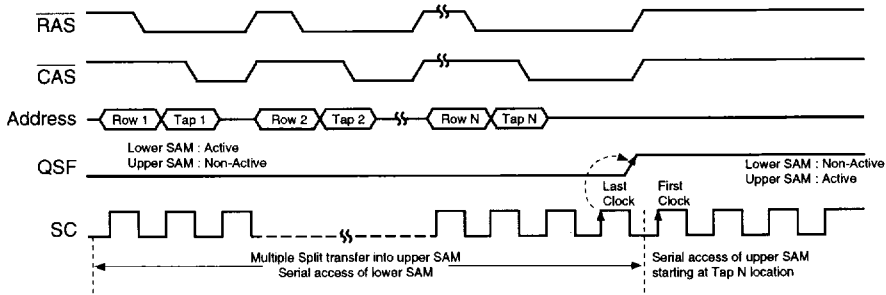

Split Read/Write Transfer Operation Allowable Period

Figure 26 illustrates the relationship between the serial clock SC and the special function output QSF during split read/write transfers and highlights the time periods where split transfers are allowed,

relative to SC and QSF. As indicated in Figure 26, a split read/write transfer is not allowed during the period of $t_{STH} + t_{STS}$.

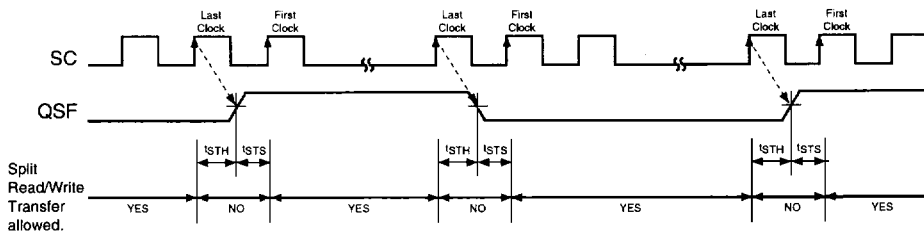
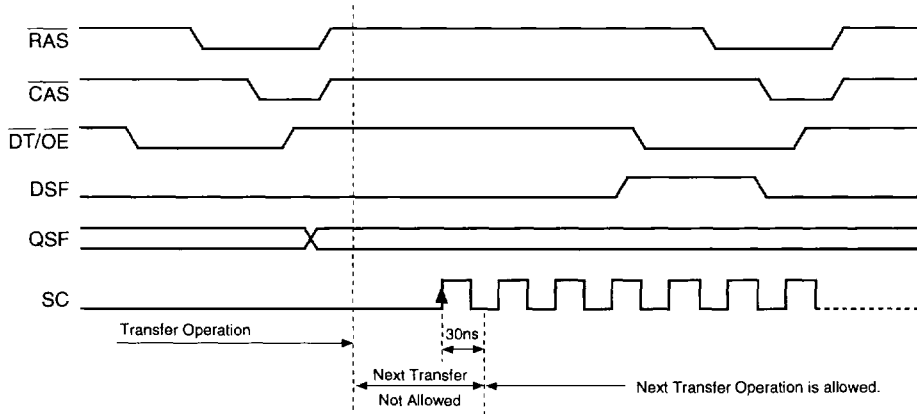

Figure 26. Split Transfer Operation Allowable Periods

Split Transfer Cycle After Normal Transfer Cycle

A split transfer may be performed following a normal transfer (Read/Write/Pseudo-Write transfer) provided that a minimum delay of 30ns from the

rising edge of the first clock SC is satisfied (refer to the illustration shown below).



Normal Read Transfer Cycle After Normal Read Transfer Cycle

Another read transfer may be performed following the read transfer provided that a minimum delay of 30 ns from the rising edge of the first clock

SC is satisfied (refer to the illustration shown below).

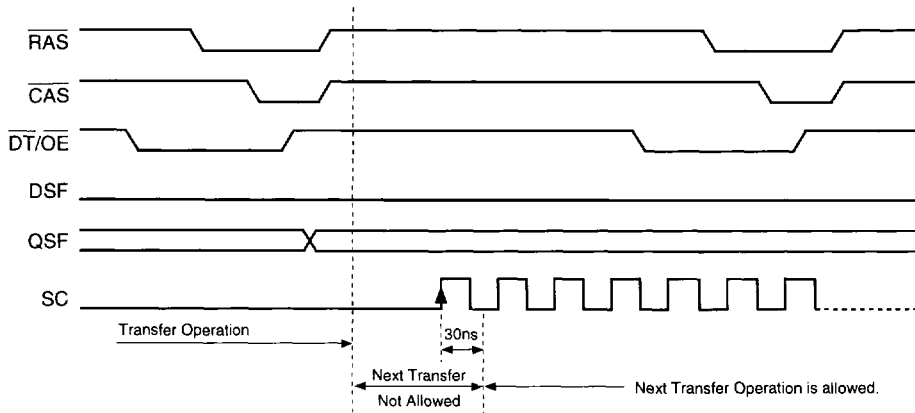

Normal Transfer After Split Transfer

A normal transfer (read/write/pseudo write) may be performed following split transfer operation

provided that a 30ns minimum delay is satisfied after the QSF signal toggles.

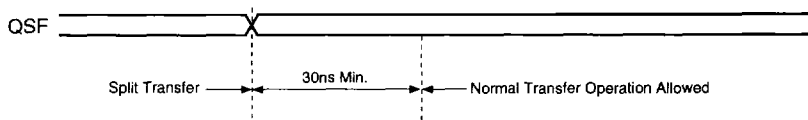

Power-Up

Power must be applied to the \overline{RAS} and $\overline{DT/OE}$ input signals to pull them "high" before or at the same time as the V_{DD} supply is turned on. After power-up, a pause of 200 μ seconds minimum is required with \overline{RAS} and $\overline{DT/OE}$ held "high". After the pause, a minimum of 8 \overline{RAS} and 8 SC dummy cycles must be performed to stabilize the internal circuitry, before valid read, write or transfer operations can begin. During the initialization period, the $\overline{DT/OE}$ signal must be held "high". If the internal refresh counter is used, a minimum 8 \overline{CAS} -before- \overline{RAS} initialization cycles are required instead of 8 \overline{RAS} cycles.

Initial State After Power-Up

When power is achieved with \overline{RAS} , \overline{CAS} , $\overline{DT/OE}$ and $\overline{WB/WE}$ held "high", the internal state of the V52C4258 is automatically set as follows.

However, the initial state can not be guaranteed for various power-up conditions and input signal levels. Therefore, it is recommended that the initial state be set after the initialization of the device is performed (200 μ s pause followed by a minimum of 8 \overline{RAS} cycles and 8 SC cycles) and before valid operations begin.

3

	State after power-up
SAM port	Input Mode
QSF	High-Impedance
Color Register	all "0"
WM1 Register	Write Enable
TAP pointer	Invalid