

Technical Data

ST41xx Series

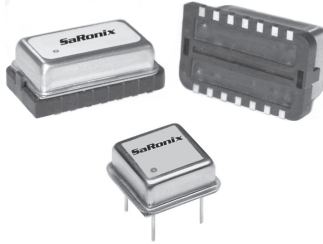

Description

A crystal controlled, low-current oscillator providing precise rise and fall times to drive ACMOS/LVCMOS loads. The tri-state function enables the output to go high impedance. Available in either a 14 or an 8 pin DIP compatible, resistance welded, all metal case. Pin 7 (or Pin 4) is grounded to case to reduce EMI. True SMD DIL 14 version also available, utilizing new adaptor technology (see separate data sheet for package dimensions).

Applications & Features

- Fiber Channel
- Gigabit Ethernet
- HCMOS/ACMOS/LVCMOS MPU's
- 3.3 or 5V operation
- High Drive capability
- Tri-State output standard
- Short circuit protected output
- Plastic SMD available, see ST41xH Series data sheet.
- Ceramic SMD available, see S19xx Series data sheet.
- True SMD version available, select option S in part number builder (see separate data sheet for package dimensions).

Frequency Range:	32 MHz to 125 MHz
Frequency Stability:	±20, ±25, ±50 or ±100 ppm over all conditions: calibration tolerance, operating temperature, input voltage change, load change, aging*, shock and vibration. *1 year @ +40°C average ambient operating temperature

Temperature Range:	Operating: 0 to +70°C or -40 to +85°C Storage: -55 to +125°C
---------------------------	---

Supply Voltage:	Recommended Operating: +5V ±5% or 3.3V ±10%
------------------------	---

Supply Current:	50mA typ, 65mA, 35mA max @ 3.3V
------------------------	---------------------------------

Output Drive:	Symmetry:	ACMOS	ACMOS	TTL	TTL
		32 to 60 MHz	60+ to 125 MHz	32 to 60 MHz	60+ to 125 MHz
	0 to +70°C:	45/55%	45/55%	45/55%	45/55%
	-40 to +85°C:	45/55%	40/60%	45/55%	40/60%
		(45/55% @ 3.3V)			
	Rise & Fall Times:	2ns max 20% to 80% VDD 1.5ns max 0.5 to 2.5V			
	Logic 0:	10% VDD max or 20% VDD max @ 3.3V			
	Logic 1:	80% VDD min or 80% VDD min @ 3.3V			
	Load:	50Ω ACMOS or 95Ω ACMOS @ 3.3V			
	Period Jitter RMS:	13ps max 32 to 72 MHz 20ps max 72+ to 125 MHz, 0 to +70°C 25ps max 72+ to 125 MHz, -40 to +85°C			

Mechanical:	Shock:	MIL-STD-883, Method 2002, Condition B
	Solderability:	MIL-STD-883, Method 2003
	Terminal Strength:	MIL-STD-883, Method 2004, Condition B2
	Vibration:	MIL-STD-883, Method 2007, Condition A
	Solvent Resistance:	MIL-STD-202, Method 215
	Resistance to Soldering Heat:	MIL-STD-202, Method 210, Condition A, B or C (I or J for Gull Wing or SMD)

Environmental:	Gross Leak Test:	MIL-STD-883, Method 1014, Condition C
	Fine Leak Test:	MIL-STD-883, Method 1014, Condition A2
	Thermal Shock:	MIL-STD-883, Method 1011, Condition A
	Moisture Resistance:	MIL-STD-883, Method 1004

Part Numbering Guide

ST41 3 0 A - 106.2500 (T)	
Series	Packing Method
Type	(T) = Tape & Reel for SMD versions full reel increments only (200pcs) Blank = Bulk
3 = 3.3V LVCMOS 5 = 5V TTL 6 = 5V ACMOS	Frequency
Package Style	Stability Tolerance
0 = Full Size, Metal 9 = Half Size, Metal J = Half Size, Metal, Gull Wing K = Full Size, Metal, Gull Wing S = True SMD Adaptor (see product photo)	AA = ±20 ppm, 0 to +70°C A = ±25 ppm, 0 to +70°C B = ±50 ppm, 0 to +70°C C = ±100 ppm, 0 to +70°C E = ±50 ppm, -40 to +85°C F = ±100 ppm, -40 to +85°C

DS-183 REV C

Technical Data

ST41xx Series

Package Details

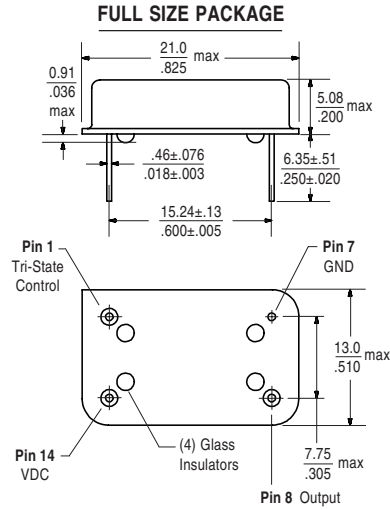

Standard Marking Format **
Includes Date Code, Frequency, Part Number

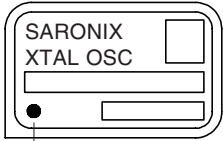

HALF SIZE PACKAGE

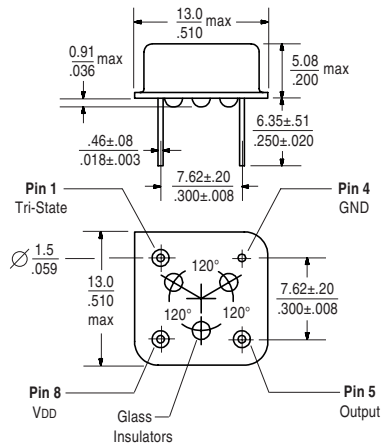

Standard Marking Format **
Includes Date Code, Frequency, Part Number



** Exact location of items may vary

Scale: None (Dimensions in $\frac{\text{mm}}{\text{inches}}$)

Output Waveform

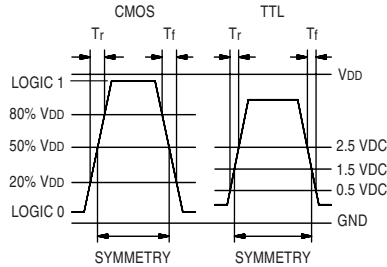

Tri-State Logic Table

Pin 1 Input	Pin 8 (5) Output
Logic 1 or NC	Oscillation
Logic 0 or GND	High Impedance

Required Input Levels on Pin 1:
Logic 1 = 2.2V min
Logic 0 = 0.8V max

Test Circuits

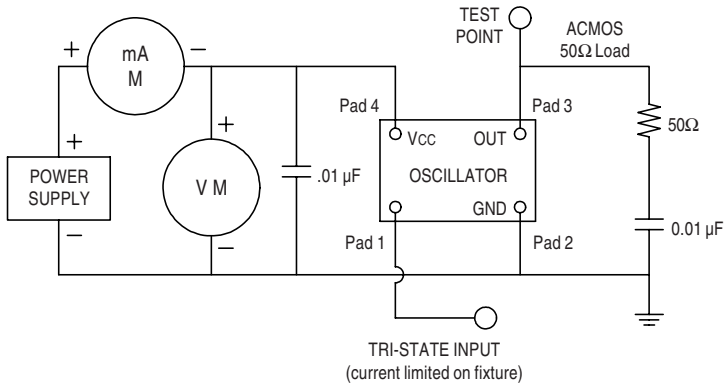

50Ω AC MOS TEST CIRCUIT

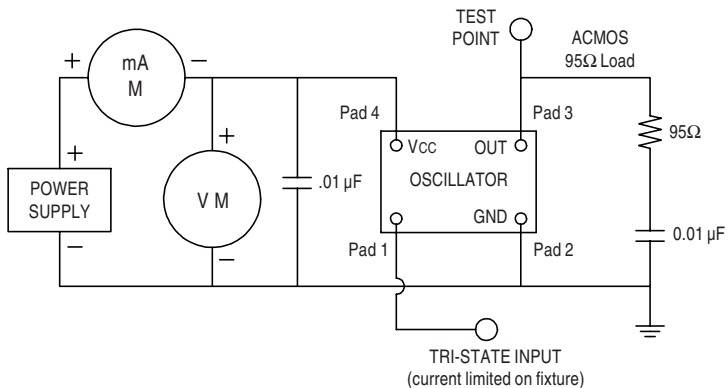

95Ω AC MOS TEST CIRCUIT

All specifications are subject to change without notice.

True SMD Adaptor - 7.57mm High

Technical Data

