

NI Type Oven Controlled Crystal Oscillator

RoHS Compliant Optional

FEATURE

1. Typical 36.0 x 27.0 x 15.0 mm.
2. Stratum 3E Performance.
3. The Lowest Cost Highly Stable Oscillator for Telecom Application.



ORDERING INFORMATION

N	I	A	D	E	D	W			H	N	L	?
OCXO	Package (mm)	Supply Voltage (V)	Pulling Range (PPM)	Freq. Stability (PPb)	Temp. Range (°C)	Output Logic and Symmetry			Oscillator Mode	Appearance	Marking	— Dash Freq. (MHz)
	L:36 W:27 H:15	A:12 T:5	D: ±1 E: ±5	B: ±10 C: ±20 E: ±30 F: ±40 G: ±50 H: ±100	X: 0~+60 E: 0~+70 C: -20~+70 D: -30~+70 T: -40~+70	TTL 15pF TTL 50pF CMOS 15pF CMOS 50pF SINE WAVE	50±5% A E J F W	50±10% B R K G	A:AT Fundamental T:AT 3 rd Overtone F:AT 5 th Overtone S:AT 7 th Overtone H:SC 3 rd Overtone I:SC 5 th Overtone J:SC 7 th Overtone	N:Normal	L:Laser Marking F:Laser Marking (RoHS Compliant)	xx.xxxxx

Ordering example: NIADEDWHNL-10.000000 MHz

VCC: 12V, Frequency Stability: ±30ppb, -30°C to +70°C. Load: 50Ω. SC-3rd Overtone, Laser Marking, Freq. 10.000000MHz

FREQ. STABILITY vs. TEMP.RANGE {O:AT O:SC}

Temp.(°C)	PPB	B: ±10	C: ±20	D: ±25	E: ±30	F: ±40	G: ±50	H: ±100
X	0 ~ +60	X	△	X	△	X	△	○
E	0 ~ +70	X	△	X	△	X	△	○
C	-20 ~ +70	X	△	X	△	X	△	○
D	-30 ~ +70	X	△	X	△	X	△	○
T	-40 ~ +70	X	△	X	△	X	△	○

○:Standard △:Available (case by case) ×:Not available

OUTLINE DRAWING

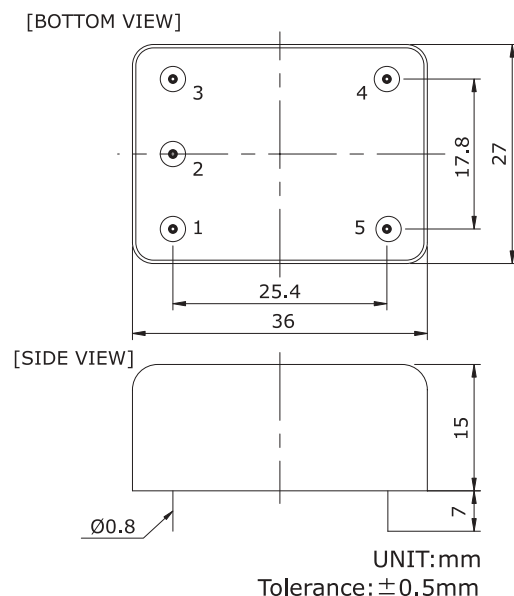

PIN	FUNCTION
1	CONTROL VOLTAGE IN
2	N.C. or REF. VOLT. OUTPUT
3	SUPPLY VOLTAGE
4	RF OUTPUT
5	GND/CASE

MARK:
IADEDW
10.000000MHz
 0145

ELECTRICAL SPECIFICATION

	Min	Nominal	Max	Note	Unit	
NOMINAL FREQUENCY		10			MHz	
TEMPERATURE RANGE						
Operating	-40		70		°C	
Storage	-55		100		°C	
POWER SUPPLY	11.4	12	12.6	Vcc±5%	V	
CURRENT CONSUMPTION						
At switch on			400		mA	
At steady state@25°C			180		mA	
FREQUENCY ADJUSTMENT						
Control voltage range	0.5		4.5		V	
Pulling range		1.0			±ppm	
Linearity			10		%	
Slope		Positive				
Reference voltage	4.75	5.0	5.25		V	
OUTPUT SIGNAL WAVEFORM				Sine wave		
Level	5	7	9		dbm	
Duty cycle					%	
Rise time / Fall time					ns	
Load		50			Ω	
Spurious					dBc	
Harmonics			-30		dBc	
FREQUENCY STABILITY						
Vs temperature range		30		Reference to freq at 25°C Vcc ±5%	±ppb	
Vs power supply		10		Vcc ±5%	±ppb	
Vs load		10		5% change from 50ohm	±ppb	
Vs warm up time at 25°C		50		Warm up time 10 minutes Reference to freq at 1 hour	±ppb	
AGING	1 day	1 year	10 years	After 30 Days of Operation		
Medium/long term stability	0.001	0.1			±ppm	
Allan variance	0.1 s	1 s	10 s		±ppb	
RETRACE	30mn	1h	24h	After 24 hours turn off	±ppb	
PHASE NOISE	1 Hz	10 Hz	100 Hz	1 KHz	10 KHz	100 KHz
		-105	-125	-145	-150	
						dBc/Hz

Available Frequency Range: 10MHz to 50MHz including 10.0, 20.0, 50.0MHz.

Available Options: Sine wave or Square Wave Output, Low Phase Noise, Different Input Voltage, Fast Warm Up.