



Sound Blaster™ Compatible Mixer

General Description

The ICS2102 is a CMOS integrated circuit that provides mixing of 4 stereo and 1 monaural audio signals as well as master volume control. These functions are digitally controlled through Sound Blaster compatible mixer registers, an 8 bit parallel interface. The monaural microphone input has 4 levels of attenuation. The remaining 8 input channels have 8 levels of attenuation. The four stereo channels and one monaural channel are summed to form a composite signal before global volume controls are added. The master volume may be programmed with one of 8 levels of attenuation. This component performs all the necessary audio mixing for a product that is compatible with Sound Blaster Pro.™

Features

- 4 channel stereo and 1 monaural mixing
- 8 levels of independent channel input attenuation control, except microphone (4 levels)
- 8 level master volume control
- 5V CMOS process
- 28-pin SOIC package

Block Diagram

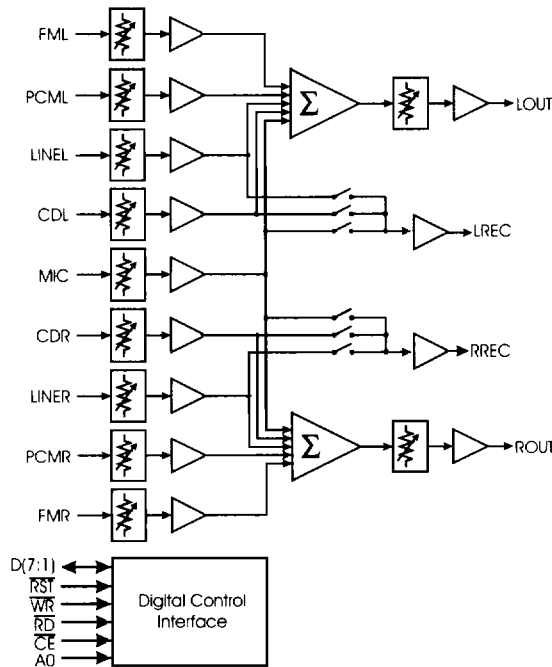

Sound Blaster and Sound Blaster Pro are trademarks of Creative Technologies, Inc.



Pin Configuration

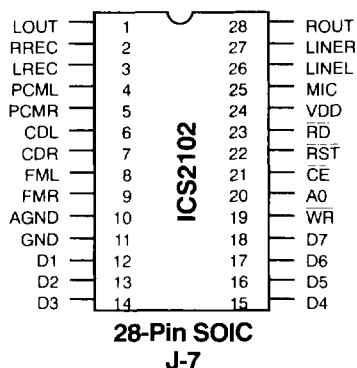

Pin Descriptions

PIN NUMBER	PIN NAME	TYPE	DESCRIPTION
4	PCML	Analog input	Left PCM input channel.
5	PCMR	Analog input	Right PCM input channel.
8	FML	Analog input	Left FM input channel.
9	FMR	Analog input	Right FM input channel.
6	CDL	Analog input	Left CD input channel.
7	CDR	Analog input	Right CD input channel.
26	LINEL	Analog input	Left line input channel.
27	LINER	Analog input	Right line input channel.
25	MIC	Analog input	Microphone input channel.
19	WR	Digital input	Write Enable.
23	RD	Digital input	Read Enable.
21	CE	Digital input	Chip Enable.
22	RST	Digital input	Hardware Reset.
20	A0	Digital input	Address bit 0.
12	D1	Digital input	Data bit 1.
13	D2	Digital input	Data bit 2.
14	D3	Digital input	Data bit 3.
15	D4	Digital input	Data bit 4.
16	D5	Digital input	Data bit 5.
17	D6	Digital input	Data bit 6.
18	D7	Digital input	Data bit 7.
1	LOUT	Analog output	Left audio output.
28	ROUT	Analog output	Right audio output.
3	LREC	Analog output	Left record output.
2	RREC	Analog output	Right record output.
11	DGND	Power	Digital ground.
10	AGND	Power	Analog ground.
24	VDD	Power	Positive supply voltage.



Pin Descriptions

xL, xR: Left and right channel inputs. These pins are used as the four pairs of inputs for the audio signals to be attenuated and then mixed. The signals applied to these pins should not exceed the supply voltage.

MIC: Microphone input. This analog signal is first attenuated and then routed to both left and right channels. It is the only mono input routed to both channels.

LOUT, ROUT: Audio output left and right. These pins are connected to buffer amplifiers that are in turn driven from the volume control. This output should be used to drive the amplifier section of the final sound reproduction system.

LREC, RREC: A second set of audio outputs used for recording one of three inputs: LINE, CD or MIC. The Input Selection Register determines which source is connected to the LREC and RREC outputs.

VDD: Digital and Analog supply. This pin supplies the analog section and digital interface of the mixer and should not be greater than 5V above the analog ground (AGND).

AGND: Analog ground. This pin is used as the negative supply of the analog section.

DGND: Digital ground. This pin is used as a reference for the digital section of the mixer. The potential at this pin should be externally tied to the chassis ground on the board where AGND is also connected.

A0: Address bit 0. This pin, when driven low, determines that the incoming data is an index. When high, the incoming data is data to set the register indicated on the previous data transfer.

\overline{WR} : Write Pulse (Low Active). The write line is pulsed low while the chip enable line is a low. A 7 bit data load will occur using data pins 1 to 7.

\overline{RD} : Read Pulse (Low Active). The read line is pulsed low while the chip enable line is low. A 7 bit data read will occur using data pins 1 to 7.

\overline{CE} : Chip Enable (Low Active). This line should be pulsed low in order to initiate a transfer of control information to the digital control section. If this line and the write line are low, a byte transfer will occur.

\overline{RST} : Hardware Reset (Low Active). This line resets the default setting of the mixer. The application circuit will use the inverted version of the PC reset line.

DI-7: Data bits 1-7: These lines are used for parallel transfers to the digital control section. A parallel transfer occurs when both the chip enable (\overline{CE}) and write pulse (\overline{WR}) or read pulse (\overline{RD}) lines are low. D0 (LSB), not having any impact on both index (address) decoding or actual data, has been omitted.





Registers

Overview

Communication to each internal register of the mixer requires that two byte transfers are completed. The first byte must contain the index (or address) of the register which is to be loaded. The second byte should contain the data that is to be written. The external address line A0 is used to discriminate between an index write and a data write. If the A0 is set to a logic 0, it is identified as an index transfer and if it is set to a logic 1, then the transfer is identified as data. The data transfer is valid only when /CE pin is pulsed low. In this manner an 8 bit bus with multiple uses can be shared for communication.

Register Maps

Address Transfer Definitions

An address transfer is one in which A0 bit is set to a logic 0, whatever the base address might be. The decode of this address is as follows:

D7	D6	D5	D4	D3	D2	D1	Accessed Register (Hex)
		Mixer Data Reset					00/01
	Left PCM Input		X/1		Right PCM Input		04/05
	X/0		X/1	X/0	MIC Input		0A/0B
	X/0		X/1	X/0	Input Sel.		0C/0D
	L. Master Volume		X/1		R. Master Volume		22/23
	Left FM Input		X/1		Right FM Input		26/27
	Left CD Input		X/1		Right CD Input		28/29
	Left Line Input		X/1		Right Line Input		2E/2F

X/1=Ignored on write operations, read back as 1.

X/0=Ignored on write operations, read back as 0.



Ghost Address Definitions

Some of the actual registers described on the previous page are duplicated by partial decoding. Omitting certain address bits for decoding, the decode is as follows:

D7	D6	D5	D4	D3	D2	D1	Accessed Register (Hex)
			X/1				L. Master V. Ghost 02/03
			X/1				Left FM Ghost 06/07
			X/1				Left CD Ghost 08/09
				X/1			R. Master V. Ghost
				X/1			"Right" FM Ghost
				X/1			"Right" CD Ghost

Channel Control Register (except Microphone input)

D3/D7	D2/D6	D1/D5	D4	Function
0	0	0	X/1	Mute this channel
0	0	1	X/1	28dB attenuation
0	1	0	X/1	21.5dB attenuation
0	1	1	X/1	16dB attenuation
1	0	0	X/1	11dB attenuation
1	0	1	X/1	7dB attenuation
1	1	0	X/1	3.3dB attenuation
1	1	1	X/1	0dB attenuation

There are 5 control registers in the ICS2102. The higher 3 bits of each nibble register selects the desired level of attenuation for that channel. The lowest level of attenuation (or highest volume) corresponds to a setting of all 1s for the attenuation field. Attenuation steps increase at varying dB per step until 28dB is reached with a register value in the attenuation field of 001x. The final step does not simply add an additional 6dB attenuation but acts as a mute function by completely killing the input.

The only exception to this is the Microphone input attenuation control that uses D[2-1] for the 8 levels.





Microphone Input Control Register

D2	D1	Function
0	0	Mute this channel (Default)
0	1	19dB attenuation
1	0	11dB attenuation
1	1	6dB attenuation

Input Selection Register

D2	D1	Function
0	0	Microphone (Default)
0	1	CD Input
1	0	Microphone
1	1	Line-In

Default Settings

The default values are set when the part is powered on. The same default values are also set when a hardware reset (low active, pin \overline{RST}) occurs. When reset by writing to 00 index (Data Reset register), the ICS2102 sets the input attenuations of the FM, PCM inputs and the master volume to 99h, while all others are muted (00h). The recording selector switch connects the microphone input to the recording path.

Register Descriptions

Reset Register (Index 00)

When the PC writes any value to this register, the mixer will reset, and all registers will return to their default values. The reset occurs with a write to this register. The default values will load once the data is also written.

PCM Volume Register (Index 04)

The PC uses this register to set the PCM input attenuation level. This register can also be programmed by writing to the lower nibble of index register 24h. When programmed in this way, the lower nibble written will set both the left and right PCM volumes. The default value for this register is 99h.

MIC Input Attenuation Register (Index 0A)

The recording volume of the microphone input is set through this register. The setting of the levels is described in a previous table. The default value for this register is 00h.

Input Selector for Recording (Index 0C)

The recording of a single channel is defined through the selection described in the previous table.

Master Volume Register (Index 22)

The PC uses this register to set the overall volume level. This register can also be programmed via the lower nibble of index register 02h. When programmed this way, the nibble written will set both the left and right master volumes. The default value for this register is 99h.

FM Volume Register (Index 26)

The PC uses this register to set the FM input attenuation level. This register can also be programmed by writing to the lower nibble of index register 06h. When programmed this way, the lower nibble will set both the left and right FM volume settings. The default value for this register is 99h.

CD Volume Register (Index 28)

The PC uses this register to set the CD input attenuation level. This register can also be programmed by writing to the lower nibble of index register 08h. When programmed this way, the lower nibble will set both the left and right CD volume settings. The default value for this register is 00h.

Line In Volume Register (Index 2E)

The PC uses this register to set the line-in input attenuation level. The default value for this register is 00h.

Ghost Registers

Master Volume Ghost Register (Index 02)

When this register is written, the lower nibble (bits 3-0) are written to both the left and right Master volume settings at index register 22h. The default value for this register is 99h.

FM Volume Ghost Register (Index 06)

When this register is written, the lower nibble (bits 3-0) are written to both the left and right FM volume settings at index register 26h. The default value for this register is 99h.

CD Volume Ghost Register (Index 08)

When this register is written, the lower nibble (bits 3-0) are written to both the left and right CD volume settings at index register 28h. The default value for this register is 00h.



Absolute Maximum Ratings

All voltages measured with respect to ground potential node where AGND and DGND are connected.

$T_A=0^{\circ}\text{C}$ to 70°C unless otherwise noted.

PARAMETER	SYMBOL	TEST CONDITIONS	LIMIT	UNIT
Positive Supply Voltage	V_{DD}	V_{DD}	-0.3 to +7.0	V
Digital Input Voltage	V_{IN}	All digital inputs	-0.3 to $V_{DD}+0.3$	V
Analog Input Voltage	V_{INA}	All analog inputs	$V_{SS}-0.3$ to $V_{DD}+0.3$	V
Storage Temperature	T_{Stg}		-25 to 120	$^{\circ}\text{C}$

Stresses above those listed under Absolute Maximum Ratings may cause permanent damage to the device. This is a stress rating only and functional operation of the device at these or any other conditions above those indicated in the operational sections of the specifications is not implied. Exposure to absolute maximum rating conditions for extended periods may affect product reliability.

Recommended Operating Conditions

$T_A=0^{\circ}\text{C}$ to 70°C unless otherwise noted

PARAMETER	SYMBOL	TEST CONDITIONS	MIN	TYP	MAX	UNIT
Positive Supply Voltage	V_{DD}	V_{DD}	4.75	5	5.25	V
Digital Input Voltage	V_{IN}	All digital inputs	-0.3	-	$V_{DD}+0.3$	V
Analog Input Voltage	V_{INA}	All analog inputs	$V_{SS}-0.3$	-	$V_{DD}+0.3$	V
Storage Temperature	T_{Stg}		0	-	70	$^{\circ}\text{C}$

Electrical Characteristics

The following characteristics apply for $DV_{DD}=5V$, $V_{DD}=5V$ supply voltage, $f_{IN}=1\text{ kHz}$ and $V_{IN}=3V_{rms}$ input signal; master volume and input attenuation all 0dB, unless otherwise specified. All limits apply for $T=25^{\circ}C$.

PARAMETER	SYMBOL	TEST CONDITIONS	MIN	TYP	MAX	UNITS
Supply Current	I_{VDD}	All xL/xR inputs, volumes mute; all digital inputs at GND level, except CE, A0, WR and RD at V_{DD}	-	12	15	mA
Input Voltage (RMS)	V_{IN}	THD=0.5%, $R_L=10k\Omega$	1	-	-	V
Total Harmonic Distortion	THD	$1 V_{rms}$, $R_L=10k\Omega$	-	.08	0.5	%
		$f_{IN}=100\text{ Hz}$	-	.13	0.5	
		$f_{IN}=1\text{ kHz}$	-	.65	0.8	
		$f_{IN}=10\text{ kHz}$	-	-	-	
DC Operating Voltage	V_{CO}	@ LOUT, ROUT	-	2.14	-	V
AC Output Impedance	r_{out}	LOUT, ROUT, $R_L=10k\Omega$	-	100	1k	Ω
Input Impedance	r_{in}	xL, xR	100k	300k	-	Ω
Volume Control		Maximum setting (0dB)	-0.5	0	0.5	dB
		Minimum setting (28dB)	-26	-28	-29	
Volume Step Size Error		(Actual-Nom)/Nom	-	-	5	%
Channel Separation		Inputs mute. Drv xL, monitor xR	-60	-	-	dB
Input Attenuation Control (except Microphone input)		Maximum setting (0dB)	-0.5	0	0.5	dB
		Minimum setting (28dB)	-26	-28	-29	
(Microphone input only)		Minimum setting (-19dB)	-18	-19	-20	
Input Attenuation Step Size Error			-	-	5	%
Mute Attenuation		$V_{IN}=1V_{rms}$, xL, xR	72	-	-	dB
Frequency Response		$f_{IN}=0.02\text{-}20\text{ kHz}$, rel. to 1 kHz	-	-	± 0.2	dB
Signal-to-Noise Ratio	SNR	$V_{IN}=1V_{rms}$	72	85	-	dB
Power Supply Rejection Ratio	PSRR	Apply $.2V_{rms}$, 100 Hz to V_{DD} ; mute inputs. Check LOUT.	-	-6	-	dB
Read Access Time	T_{RA}		50	-	-	ns
Chip Enable Access Time	T_{CA}		50	-	-	ns
Data Read Hold Time	T_{DHR}		25	-	-	ns
Chip Enable Setup Time	T_{CS}		50	-	-	ns
Write Strobe Time	T_{WS}		20	-	-	ns
Address Setup Time	T_{AS}		5	-	-	ns
Address Hold Time	T_{AH}		5	-	-	ns
Chip Enable Hold Time	T_{CH}		5	-	-	ns
Data Write Setup Time	T_{DSW}		20	-	-	ns
Data Write Hold Time	T_{DHW}		5	-	-	ns
Logic "1" Input	V _{IH}	Digital signals	2.0	-	-	V
Logic "0" Input	V _{IL}	Digital signals	-	-	0.8	V



Interface Timing Definitions

Read

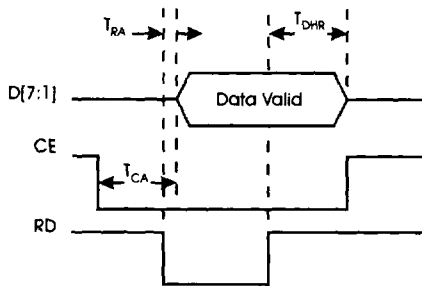

Write

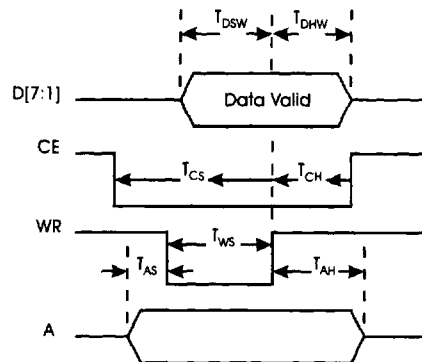



ICS2102

Ordering Information

ICS2102M

Example:

ICS XXXX M

