



Form No.: QF-1274
Edition: 2

ISO9001 ISO14001 IATF16949 **CHILISIN ELECTRONICS CORP.**
RoHS & Halogen Free & REACH Compliance.

SPECIFICATION FOR APPROVAL

Customer : _____

Customer P/N: _____

Drawing No : _____

Quantity : 0 Pcs. Date : 2020/6/2

Chilisin P/N : BCTF Series

SPECIFICATION ACCEPTED BY:

COMPONENT ENGINEER	
ELECTRICAL ENGINEER	
MECHANICAL ENGINEER	
APPROVED	
REJECTED	

奇力新電子股份有限公司

Chilisin Electronics Corp
No. 29, Alley 301, Tehhsin Rd.,
Hukou, Hsinchu 303, Taiwan
TEL : +886-3- 599-2646
FAX : +886-3- 599-9176
E-mail : sales@chilisin.com
http : //www.chilisin.com

東莞奇力新電子(東莞廠)有限公司

Chilisin Electronics (Dongguan) Co., Ltd.
No. 78, Puxing Rd., Yuliangwei Administration
Area, Qingxi Town, Dongguan City,
Guangdong, China
TEL : +86-769-8773-0251-3
FAX : +86-769-8773-0232
E-mail : cect@chilisin.com

奇力新電子(越南廠)有限公司

Chilisin Electronics (Vietnam) Limited
No 143 - 145, Road No 10, VSIP Hai Phong,
Lap Le Commune, Thuy Nguyen Dist,
Haiphong City, Vietnam
Tel : 84-316 255 688
Fax : 84-316 255 689
E-mail : sales@chilisin.com

奇力新電子(湖南廠)有限公司

HuNan Chilisin Electronics Technology Co., Ltd
No. 8, Shaziao Liangshuijing Town, Yuanling
County, Huaihua City, Hunan Province 419601,
China
Tel : 86-745-867-5882
E-mail : cect@chilisin.com

Drawn by
Desmond.Wu

Checked by
Cf.Hsieh

Approved by
WI.Liu



BCTF Series Specification

1 Scope:

- 1-1 This specification is applicable to fully lead-free and halogen-free BCTF series thick film chip resistors.
- 1-2 Fully lead-free products – No RoHS exemptions.
- 1-3 The product is for general electronic purpose.

2 Part Numbering:

B	C	T	F	0 0	0 4 0 2	-	1 0 0 2	F	TH
Series				Internal Code	Dimension (inch)		Resistance Value	Tolerance	Taping Code
BCTF: Fully Lead-free Thick Film Chip Resistors					0201 0402 0603 0805 1206 1210 2010 2512		J Tol: (3 digit + X) E-24 Series Ex. 10Ω = 100X 4.7Ω = 4R7X Jumper = 000X F/D/B Tol: (4 digit) E-96 Series Ex. 10.2 Ω = 10R2 10KΩ = 1002 Jumper = 0000	B = ± 0.1% D = ± 0.5% F = ± 1% J = ± 5%	TH(10000pcs/reel) : 0201, 0402 TP(5000pcs/reel) : 0603, 0805, 1206, 1210 TE(4000pcs/reel) : 2010, 2512

3 SPECIFICATIONS:

Type	Rated Power at 70°C	Max. Working Voltage	Max. Overload Voltage	T.C.R (ppm/°C)	Resistance Range				JUMPER Rated Current		JUMPER Resistance Value	
					B(±0.1%)	D(±0.5%)	F(±1%)	J(±5%)	J	F	J	F
					E-24、E-96	E-24、E-96	E-24、E-96	E-24	(±5%)	(±1%)	(±5%)	(±1%)
BCTF_0201	1/20W	25V	50V	±200	100Ω ≤ R ≤ 1MΩ	10Ω ≤ R ≤ 1MΩ	10Ω ≤ R ≤ 10MΩ	10Ω ≤ R ≤ 10MΩ	0.5A	0.5A	50mΩ MAX.	35mΩ MAX.
BCTF_0402	1/16W	50V	100V	±200	100Ω ≤ R ≤ 1MΩ	1Ω ≤ R ≤ 2.2MΩ	1Ω ≤ R ≤ 10MΩ	1Ω ≤ R ≤ 10MΩ	1A	1.5A	50mΩ MAX.	20mΩ MAX.
BCTF_0603	1/10W	75V	150V	±150	100Ω ≤ R ≤ 1MΩ	1Ω ≤ R ≤ 2.2MΩ	1Ω ≤ R ≤ 2.2MΩ	1Ω ≤ R ≤ 2.2MΩ	1A	2A	50mΩ MAX.	20mΩ MAX.
				±200	-----	-----	2.2MΩ < R ≤ 10MΩ	2.2MΩ < R ≤ 10MΩ				
BCTF_0805	1/8W	150V	300V	±150	100Ω ≤ R ≤ 1MΩ	1Ω ≤ R ≤ 2.2MΩ	1Ω ≤ R ≤ 2.2MΩ	1Ω ≤ R ≤ 2.2MΩ	2A	2.5A	50mΩ MAX.	20mΩ MAX.
				±200	-----	-----	2.2MΩ < R ≤ 10MΩ	2.2MΩ < R ≤ 10MΩ				
BCTF_1206	1/4W	200V	400V	±150	100Ω ≤ R ≤ 1MΩ	1Ω ≤ R ≤ 2.2MΩ	1Ω ≤ R ≤ 2.2MΩ	1Ω ≤ R ≤ 2.2MΩ	2A	3.5A	50mΩ MAX.	20mΩ MAX.
				±200	-----	-----	2.2MΩ < R ≤ 10MΩ	2.2MΩ < R ≤ 10MΩ				
BCTF_1210	1/2W	200V	400V	±150	100Ω ≤ R ≤ 1MΩ	1Ω ≤ R ≤ 2.2MΩ	1Ω ≤ R ≤ 2.2MΩ	1Ω ≤ R ≤ 2.2MΩ	2A	4A	50mΩ MAX.	20mΩ MAX.
				±200	-----	-----	2.2MΩ < R ≤ 10MΩ	2.2MΩ < R ≤ 10MΩ				
BCTF_2010	3/4W	200V	400V	±150	100Ω ≤ R ≤ 1MΩ	1Ω ≤ R ≤ 2.2MΩ	1Ω ≤ R ≤ 2.2MΩ	1Ω ≤ R ≤ 2.2MΩ	2A	5A	50mΩ MAX.	20mΩ MAX.
				±200	-----	-----	2.2MΩ < R ≤ 10MΩ	2.2MΩ < R ≤ 10MΩ				
BCTF_2512	1 W	200V	400V	±150	100Ω ≤ R ≤ 1MΩ	1Ω ≤ R ≤ 2.2MΩ	1Ω ≤ R ≤ 2.2MΩ	1Ω ≤ R ≤ 2.2MΩ	2A	7A	50mΩ MAX.	20mΩ MAX.
				±200	-----	-----	2.2MΩ < R ≤ 10MΩ	2.2MΩ < R ≤ 10MΩ				
Operating Temperature Range					-55°C ~ +155°C (0201:-55°C ~ +125°C)							

BCTF Series Specification

3.2 Power Derating Curve:

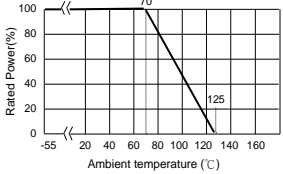
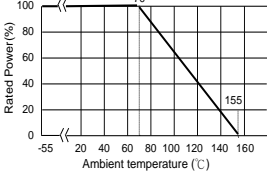
Type	BCTF000201	Other
Operating Temperature Range	-55°C ~ +125°C	-55°C ~ +155°C
Explain	If the ambient temperature exceeds 70 degrees centigrade to 125 degrees centigrade, the power can be modified by the curve as below.	If the ambient temperature exceeds 70 degrees centigrade to 155 degrees centigrade, the power can be modified by the curve as below.
Figure		

3.4 Voltage Rating:

3.4.1 Resistance Range: $\geq 1\Omega$

Rated Voltage: DC voltage or AC voltage (rms) based on the rated power.

The voltage can be calculated by the following formula. If the calculated value exceeds the Max. voltage specified in the Table 3.1, the Max. voltage rating is set as the voltage rating.

$$E = \sqrt{R \times P}$$

E= Rated voltage (v)
 P= Power rating (w)
 R= Nominal resistance(Ω)

BCTF Series Specification

4 Dimensions:



Size	Dimension	L	W	H	L1	L2
0201		0.60±0.03	0.30±0.03	0.23±0.03	0.10±0.05	0.15±0.05
0402		1.00±0.10	0.50±0.05	0.30±0.05	0.20±0.10	0.25±0.10
0603		1.60±0.10	0.80±0.10	0.45±0.10	0.30±0.15	0.30±0.15
0805		2.00±0.10	1.25±0.10	0.50±0.10	0.35±0.20	0.35±0.15
1206		3.05±0.10	1.55±0.10	0.50±0.10	0.45±0.20	0.35±0.15
1210		3.05±0.10	2.55±0.10	0.55±0.10	0.50±0.20	0.50±0.20
2010		5.00±0.20	2.50±0.20	0.55±0.10	0.60±0.20	0.60±0.20
2512		6.30±0.20	3.20±0.20	0.55±0.10	0.60±0.20	0.60±0.20

5 Structure Graph:

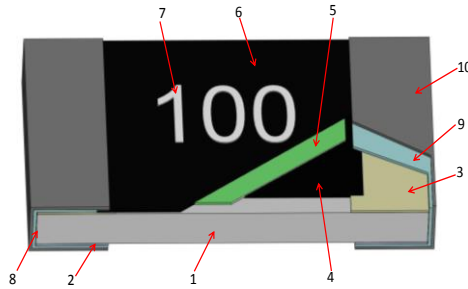

1	Ceramic substrate	6	2nd Protective coating
2	Bottom inner electrode	7	Marking
3	Top inner electrode	8	Terminal inner electrode
4	Resistive layer	9	Ni plating
5	1st Protective coating	10	Sn plating



BCTF Series Specification

6 Reliability Test:

6.1 Electrical Performance Test

No	Item	Conditions	Specifications																																	
			Resistors	Jumper																																
6-1-1	Temperature Coefficient of Resistance (TCR)	$TCR (ppm/^{\circ}C) = \frac{R2-R1}{R1 (T2-T1)} \times 10^6$ <ul style="list-style-type: none"> ●R1: Resistance at room temperature ●R2: Resistance at -55$^{\circ}C$ or +125$^{\circ}C$ ●T1: Room temperature ●T2: Temperature -55$^{\circ}C$ or +125$^{\circ}C$ ●Refer to JIS-C5201-1 4.8 	Refer to item 3. general specifications	NA																																
6-1-2	Short Time Overload	Applied 2.5 times rated voltage for 5 seconds and release the load for about 30 minutes, then measure its resistance variance rate. (Rated voltage refer to item 3. general specifications) Refer to JIS-C5201-1 4.13	0.5%、1%: $\Delta R\% = \pm 1.0\%$ 5%: $\Delta R\% = \pm 2.0\%$	Refer to item 3. general specifications																																
6-1-3	Dielectric Withstand Voltage	Put the resistor in the fixture, add VAC (see SPEC below) in +,- terminal for. 0201、0402、0603 apply 300 VAC 1 minute. 0805、1206、2010、2512 apply 500 VAC 1 minute. Refer to JIS-C5201-1 4.7	No short or burned on the appearance.																																	
6-1-4	Intermittent Overload	Put the tested resistor in chamber under temperature 25 $\pm 2^{\circ}C$ and load 2.5 times rated DC voltage for 1 sec on, 25 sec off, 10000 ⁹⁰⁰ test cycles, then it be left at no-load for 1 hour, then measure its resistance variance rate. Jumper : Applied Maximum overload current <table border="1" style="width: 100%; text-align: center; border-collapse: collapse;"> <thead> <tr> <th>Type</th> <th>0201</th> <th>0402</th> <th>0603</th> <th>0805</th> <th>1206</th> <th>2010</th> <th>2512</th> </tr> </thead> <tbody> <tr> <td>Jumper</td> <td></td> <td></td> <td></td> <td></td> <td></td> <td></td> <td></td> </tr> <tr> <td>$\pm 5\%$</td> <td>1.25A</td> <td>2.5A</td> <td>2.5A</td> <td>5A</td> <td>5A</td> <td>5A</td> <td>5A</td> </tr> <tr> <td>$\pm 1\%$</td> <td>1.25A</td> <td>3.75A</td> <td>5A</td> <td>6.25A</td> <td>8.75A</td> <td>12.5A</td> <td>17.5A</td> </tr> </tbody> </table> Refer to JIS-C5201-1 4.13	Type	0201	0402	0603	0805	1206	2010	2512	Jumper								$\pm 5\%$	1.25A	2.5A	2.5A	5A	5A	5A	5A	$\pm 1\%$	1.25A	3.75A	5A	6.25A	8.75A	12.5A	17.5A	$\Delta R\% = \pm 5.0\%$	Refer to item 3. general specifications
Type	0201	0402	0603	0805	1206	2010	2512																													
Jumper																																				
$\pm 5\%$	1.25A	2.5A	2.5A	5A	5A	5A	5A																													
$\pm 1\%$	1.25A	3.75A	5A	6.25A	8.75A	12.5A	17.5A																													

6.2 Mechanical Performance Test

No	Item	Conditions	Specifications	
			Resistors	Jumper
6-2-1	Solderability	Preconditioning Put the tested resistor in the apparatus of PCT, at a temperature of 105 $^{\circ}C$, humidity of 100% RH, and pressure of 1.22 $\times 10^5$ Pa for a duration of 4 hours. Then after left the tested resistor in room temperature for 2 hours or more. Test method: The resistor be immersed into solder pot in temperature 235 $\pm 5^{\circ}C$ for 2 sec, then the resistor is left as placed under microscope to observed its solder area. Refer to JIS-C5201-1 4.17	Solder coverage over 95%.	
6-2-2	Resistance to Soldering Heat	◎Test method 1 (Solder pot test): The tested resistor be immersed into molten solder of 260+5/-0 $^{\circ}C$ for 10 seconds. Then the resistor is left in the room for 1 hour. ◎Test method 2 (Solder pot test): The tested resistor be immersed into molten solder of 260+5/-0 $^{\circ}C$ for 30 seconds. Then the resistor is left as placed under microscope to observe its solder area. ◎Test method 2 (Solder pot test): The tested resistor be immersed into molten solder of 260+5/-0 $^{\circ}C$ for 30 seconds. Then the resistor is left as placed under microscope to observe its solder area. ◎Test method 3 (Electric iron test): Preheating temperature : 350 $\pm 10^{\circ}C$ Electric iron preheating time : 3+1/-0 sec Preheating the electric iron on electrode termination, as after that step placed the iron over 60 min. and measured its resistance variance rate.	Test item 1: (1).Variance rate on resistance $\Delta R\% = \pm 1.0\%$ Test item 2: (1).Solder coverage over 95%. (2).The underlying material(such as ceramic) shall not be visible at the crest corner area of the electrode. Test item 3: (1).Variance rate on resistance $\Delta R\% = \pm (1.0\% + 0.05\Omega)$	Refer to item 3. general specifications



ISO9001 ISO14001 IATF16949 CHILISIN ELECTRONICS CORP.

BCTF Series Specification





ISO9001 ISO14001 IATF16949 CHILISIN ELECTRONICS CORP.

BCTF Series Specification

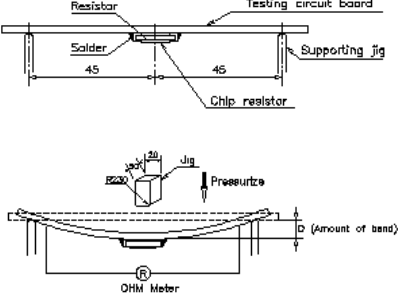
No	Item	Conditions of Test	Specifications	
			Resistors	Jumper
6-2-3	Joint Strength of Solder	Refer to JIS-C5201-1 4.32 ◎Test item 2 (Bending Strength): Solder tested resistor on to PC board add force in the middle down, and under load measured its resistance variance rate. D : 0402 · 0603 · 0805 = 5mm 0201 · 1206 · 1210 = 3mm 1812 · 2010 · 2512 = 2mm 	$\Delta R\% = \pm 1.0\%$	Refer to item 3. general specifications
		Refer to JIS-C5201-1 4.33		

6.3 Environmental Test

No	Item	Conditions of Test	Specifications									
			Resistors	Jumper								
	Resistance to Dry Heat	Put tested resistor in chamber under temperature $155 \pm 5^\circ\text{C}$ for 1000 +48/-0 hours. Then leaving the tested resistor in room temperature for 60 minutes, and measure its resistance variance rate. (0201, 0603 for $125 \pm 3^\circ\text{C}$) Refer to JIS-C5201-1 4.25	0.5% · 1%: $\Delta R\% = \pm 1.0\%$ 5%: $\Delta R\% = \pm 2.0\%$	Refer to item 3. general specifications								
	Thermal Shock	Put the tested resistor in the chamber under the Thermal Shock which shown in the following table shall be repeated 300 times consecutively. Then leaving the tested resistor in the room temperature for 1 hours, and measure its resistance variance rate. <table border="1" data-bbox="574 1388 901 1512"> <thead> <tr> <th colspan="2">Testing Condition</th> </tr> </thead> <tbody> <tr> <td>Low est Temperature</td> <td>$-55 \pm 5^\circ\text{C}$</td> </tr> <tr> <td>Highest Temperature</td> <td>$125 \pm 5^\circ\text{C}$</td> </tr> <tr> <td>Temperature-retaining time</td> <td>15 minutes each</td> </tr> </tbody> </table> Refer to MIL-STD 202 Method 107	Testing Condition		Low est Temperature	$-55 \pm 5^\circ\text{C}$	Highest Temperature	$125 \pm 5^\circ\text{C}$	Temperature-retaining time	15 minutes each	0.5% · 1%: $\Delta R\% = \pm 1.0\%$ 5%: $\Delta R\% = \pm 2.0\%$	Refer to item 3. general specifications
Testing Condition												
Low est Temperature	$-55 \pm 5^\circ\text{C}$											
Highest Temperature	$125 \pm 5^\circ\text{C}$											
Temperature-retaining time	15 minutes each											
	Loading Life in Moisture	Put the tested resistor in the chamber under temperature $40 \pm 2^\circ\text{C}$, relative humidity 90~95% and load the rated voltage for 90 minutes on, 30 minutes off, total 1000 hours. Then leaving the tested resistor in room temperature for 60 minutes, and measure its resistance variance rate. Refer to JIS-C5201-1 4.24	1. Resistance Range: $\geq 1\Omega$ <table border="1" data-bbox="1013 1556 1236 1736"> <thead> <tr> <th>Type</th> <th>$\Delta R\%$</th> </tr> </thead> <tbody> <tr> <td>0201</td> <td>0.1%、0.5%、1% $\Delta R\% = \pm 1.5\%$ 5% $\Delta R\% = \pm 3.0\%$ </td> </tr> <tr> <td>Other</td> <td>0.5%、1% $\Delta R\% = \pm 1.5\%$ 5% $\Delta R\% = \pm 3.0\%$ </td> </tr> </tbody> </table>	Type	$\Delta R\%$	0201	0.1%、0.5%、1% $\Delta R\% = \pm 1.5\%$ 5% $\Delta R\% = \pm 3.0\%$	Other	0.5%、1% $\Delta R\% = \pm 1.5\%$ 5% $\Delta R\% = \pm 3.0\%$	Refer to item 3. general specifications		
Type	$\Delta R\%$											
0201	0.1%、0.5%、1% $\Delta R\% = \pm 1.5\%$ 5% $\Delta R\% = \pm 3.0\%$											
Other	0.5%、1% $\Delta R\% = \pm 1.5\%$ 5% $\Delta R\% = \pm 3.0\%$											
	Load Life	Put the tested resistor in chamber under temperature $70 \pm 2^\circ\text{C}$ and load the rated voltage for 90 minutes on, 30 minutes off, total 1000 hours. Then leaving the tested resistor in room temperature for 60 minutes, and measure its resistance variance rate. Refer to JIS-C5201-1 4.25	<table border="1" data-bbox="1013 1747 1236 1948"> <thead> <tr> <th>Type</th> <th>$\Delta R\%$</th> </tr> </thead> <tbody> <tr> <td>0201</td> <td>0.1%、0.5%、1% $\Delta R\% = \pm 1.5\%$ 5% $\Delta R\% = \pm 3.0\%$ </td> </tr> <tr> <td>Other</td> <td>0.1%、0.5%、1% $\Delta R\% = \pm 1.5\%$ 5% $\Delta R\% = \pm 3.0\%$ </td> </tr> </tbody> </table>	Type	$\Delta R\%$	0201	0.1%、0.5%、1% $\Delta R\% = \pm 1.5\%$ 5% $\Delta R\% = \pm 3.0\%$	Other	0.1%、0.5%、1% $\Delta R\% = \pm 1.5\%$ 5% $\Delta R\% = \pm 3.0\%$	Refer to item 3. general specifications		
Type	$\Delta R\%$											
0201	0.1%、0.5%、1% $\Delta R\% = \pm 1.5\%$ 5% $\Delta R\% = \pm 3.0\%$											
Other	0.1%、0.5%、1% $\Delta R\% = \pm 1.5\%$ 5% $\Delta R\% = \pm 3.0\%$											

BCTF Series Specification

7 Technical application notes:

(This is for recommendation, please customer perform adjustment according to actual application)

7.1 Recommend Soldering Method:

7.1.1 Lead Free Reflow Soldering Profile

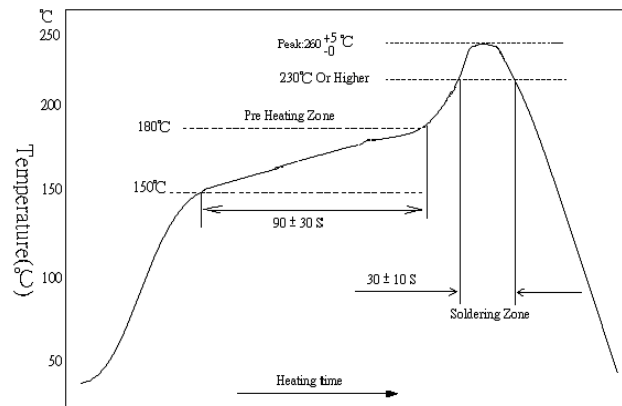

Remark: The peak temperature of soldering heat is 260 +5/-0 °C for 10 seconds

7.1.2 Lead Free Double-Wave Soldering Profile.(This applies to 0603 size inclusive above products)

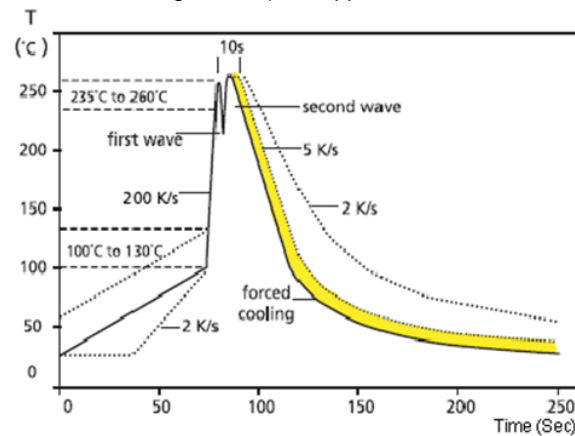

7.1.3 Soldering Iron: temperature 350°C±10°C , dwell time shall be less than 3 sec.



BCTF Series Specification

8 Recommend Land Pattern Design (For Reflow Soldering):

When a component is soldered, the resistance after soldering changes slightly depending on the size of the soldering area and the amount of soldering. When designing a circuit, it is necessary to consider the effect of a decrease or increase in its resistance.

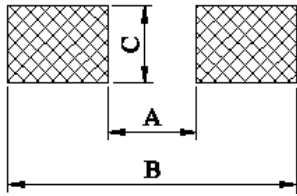

TYPE \ DIM	A	B	C
0201	0.3	1	0.4
0402	0.5	1.5	0.6
0603	0.8	2.1	0.9
0805	1.2	3	1.3
1206	2.2	4.2	1.6
1210	2.2	4.2	2.8
2010	3.5	6.1	2.8
2512	3.8	8	3.5

8.1 Environment Precautions:

This specification product is for general electronic use, CHILISIN will not be responsible for any damage, cost or loss caused by using this specification product in any special environment. If other applications need to confirm with CHILISIN.

If consumer intends to use our Company product in special environment or condition (including but not limited to those mentioned below), then will need to make individual recognition of product features and reliability accordingly.

- (a) Used in high temperature and humidity environment
- (b) Exposed to sea breeze or other corrosive gas, such as Cl₂ · H₂S · NH₃ · SO₂ and NO₂.
- (c) Used in non-verified liquids including water, oil, chemical and organic solvents.
- (d) Using non-verified resin or other coating material to seal or coat our Company product.
- (e) After soldering, it is necessary to use water-soluble detergents to clean residual solder fluxes, even though no-clean fluxes are recommended.



ISO9001 ISO14001 IATF16949 CHILISIN ELECTRONICS CORP.

BCTF Series Specification

8.2 Momentary Overload Precautions:

The product might be out of function when momentary overloaded.

Please make sure to avoid momentary overloading while using and preserving ◦

8.3 Operation and Processing Precautions:

- (a) Avoid damage to the edge of resistor and protective layer caused by mechanical stress.
- (b) Handle with care when printing circuit board (PCB) is divided or fixed on support body, because bending of printing circuit board (PCB) mounting will make mechanical stress for resistors.
- (c) Make sure the power rating is under the limit when using the resistor. When power rating is over the limit, the resistor will be overloaded. There might be machinery damage due to the climbing temperature.
- (d) If the resistor will be exposed under massive impact load (shock wave) in a short period of time, the working environment must be set up well before use.
- (e) Please make evaluation and confirmation when the product is well used in your company and have a through consideration of its fail-safe design to ensure the system safety.

9 Storage and transportation requirement:

1.1 The temperature condition must be controlled as $25\pm 5^{\circ}\text{C}$, the R.H. must be controlled as $60\pm 15\%$. The stock can maintain quality level in two years.

1.2 Please avoid the mentioned harsh environment below when storing to ensure product performance and its' weldability. Places exposed to sea breeze or other corrosive gas, such as Cl_2 、 H_2S 、 NH_3 、 SO_2 and NO_2 .

1.3 When the product is moved and stored, please ensure the correct orientation of the box. Do not drop or squeeze the box. Otherwise, the electrode or the body of the product may be damaged.

BCTF Series Specification

9 Plating Thickness:

- 9.1 Ni: $\geq 2\mu\text{m}$
- 9.2 Sn(Tin): $\geq 3\mu\text{m}$
- 9.3 Sn(Tin): Matte Sn

10 Measurement Point:

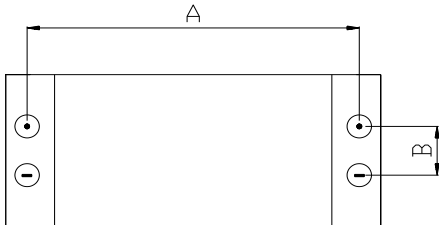
Bottom electrode		Unit : mm		
		DIM		
		TYPE	A	B
		0201	0.44±0.05	0.22±0.05
		0402	0.80±0.05	0.24±0.05
		0603	1.35±0.05	0.35±0.05
		0805	1.80±0.05	0.35±0.05
		1206	2.90±0.05	0.35±0.05
		1210	2.90±0.05	0.35±0.05
		2010	4.50±0.05	1.15±0.05
		2512	5.90±0.05	1.60±0.05

- ⊕ Current Terminal
- ⊖ Voltage Terminal





ISO9001 ISO14001 IATF16949 CHILISIN ELECTRONICS CORP.

BCTF Series Specification

11 Stock period:

The temperature condition must be controlled at $25\pm 5^{\circ}\text{C}$, the R.H. must be controlled at $60\pm 15\%$. The stock can maintain quality level in two years.

12 The carton packaged for electronic-information products is made by the symbol as follows: (for China)

	
Marking for control of pollution cause by electronic-information products	Marking for package recovery



ISO9001 ISO14001 IATF16949 CHILISIN ELECTRONICS CORP.

BCTF Series Specification

Legal disclaimer

CHILISIN, its distributors and agents (collectively, " CHILISIN"), hereby disclaims any and all liabilities for any errors, inaccuracies or incompleteness contained in any product related information, including but not limited to product specifications, datasheets, pictures and/or graphics. CHILISIN may make changes, modifications and/or improvements to product related information at any time and without notice.

CHILISIN makes no representation, warranty, and/or guarantee about the fitness of its products for any particular purpose or the continuing production of any of its products. To the maximum extent permitted by law, CHILISIN disclaims (i) any and all liability arising out of the application or use of any CHILISIN product, (ii) any and all liability, including without limitation special, consequential or incidental damages, and (iii) any and all implied warranties, including warranties of fitness for a particular purpose, non-infringement and merchantability.

CHILISIN defined this product is for general electrical use , not design for any application for automotive electrical ,life-saving or life support equipment, or any application which may inflict casualties if CHILISIN product failure occurred. When consumer is using or selling products of CHILISIN without having discussion with the sales representatives and specifically stated the applicability mentioned above in a written form, then the client need to take a full responsibility and agree to protect CHILISIN from punishment and damage.

Information provided here is intended to indicate product specifications only. CHILISIN reserves all the rights for revising this content without further notification, as long as products are unchanged. Any product change will be announced by ECN.