



FEATURES

- Direct interface to SC11004, SC11014 and SC11015 single chip modems
- Built-in UART for RS-232C interface
- Complete AT command set in firmware for intelligent modems
- 28-pin DIP or PLCC package

GENERAL DESCRIPTION

The SC11008 Modem Interface Controller is specifically designed to control Sierra's SC11004, SC11014 and SC11015 single chip, 300/1200 bit per second modems. Built with Sierra's proprietary CMOS process, the SC11008 provides a highly cost effective solution for interfacing a modem IC to a computer's RS-232 port. When connected to the SC11004/14/15, with the addition of a data access

arrangement (DAA), the SC11008 implements a Hayes-type smart modem for stand alone modem applications. All of the popular communications software written for the PC will work with the SC11004/SC11008 chip set. The

28-PIN DIP PACKAGE

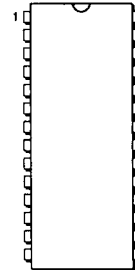

SC11008CN

28-PIN PLCC PACKAGE

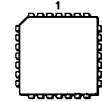

SC11008CV

SC11008 contains an 8-bit micro-processor, 8k bytes of ROM and 128 bytes of RAM and a UART. For specific high volume applications, the control program can be modified by Sierra to include additional commands and functions.

SC11008 Stand-Alone Modem Interface Controller



BLOCK DIAGRAM

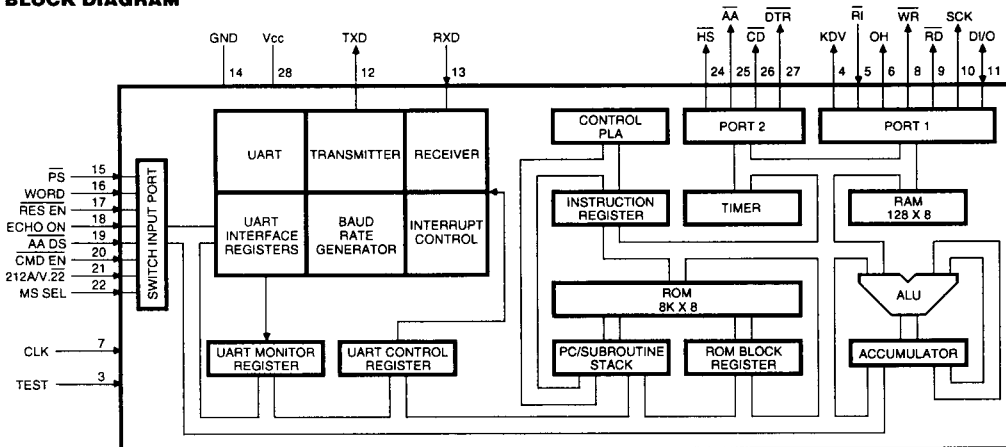

NOTE: NUMBERS NEXT TO SIGNAL NAMES REFER TO PACKAGE PINS. NUMBERS ARE FOR BOTH DIP & PLCC. PINS 1, 2, AND 23 ARE NOT CONNECTED.

PIN DESCRIPTIONS

PIN NO.	PIN NAME	I/O	DESCRIPTION
1	N.C.	—	No connection
2	N.C.	—	No connection
3	TEST	I	When the test input is high, the SC11008 enters a test mode—used for factory testing only. For normal operation, this pin must be connected to ground.
4	KDV	O	This output controls the operation of the data/voice relay. The polarity of this output is selected by \overline{PS} pin. If \overline{PS} is connected to ground, this output is active high, i.e. it is low when the modem is on hook, causing the data/voice relay to be off and the phone line is connected to the phone set. During a data call, this output goes high to operate the data/voice relay, disconnecting the phone set from the phone line. It may also be used to drive a relay for multi-line phone applications to close the A and A1 leads. If \overline{PS} pin is left open or connected to V_{CC} , this output is active low, i.e. it is high when the modem is on hook and low when the modem makes a data call.
5	\overline{RI}	I	The output of the ring detector in the DAA is connected to this input. A low level on this input indicates the On duration of the ring cycle. This is a Schmidt Trigger input, allowing for slow rising and falling signals on this pin.
6	OH	O	This output controls the operation of the hookswitch relay in the DAA. The polarity of this output is selected by \overline{PS} pin. If \overline{PS} pin is connected to ground, this output is active high, i.e. it is low when the modem is on hook. During a data call, it goes high to operate the hookswitch relay and seize the phone line. During rotary dialing, the SC11008 pulses this output at a rate of 10 pulses per second with appropriate mark/space ratio depending on 212A or V.22 mode. If \overline{PS} pin is left open or connected to V_{CC} , this output is active low, i.e. it is high when the modem is on hook and low during data call.
7	CLK	I	A 7.3728 MHz clock signal must be connected to this input. Normally, the CKOUT pin of the SC11004/14/15 modem is connected to this pin. All internal timing is derived from this clock.
8	\overline{WR}	O	This pin is used to initiate writing of data to the SC11004/14/15 modem.
9	\overline{RD}	O	This pin is used to initiate reading of data from the SC11004/14/15 modem.
10	SCK	O	The SC11008 supplies a shift clock on this pin to the SC11004/14/15 modem for reading or writing data.
11	DI/O	I/O	The SC11008 shifts data serially out of this pin to SC11004/14/15 during a write operation and shifts data serially into this pin during a read operation from the SC11004/14/15.
12	TXD	O	The SC11008 outputs serial data in asynchronous start/stop format at the data rate selected by the terminal. This data is either echo of commands received from the terminal or result codes generated by the controller during processing of the commands. This output is normally high and should be "AND"ed with the RXD output of the SC11004/14/15 to form RXD data to the terminal.
13	RXD	I	The SC11008 receives command data from the terminal on this pin. The UART in the controller connects the serial asynchronous start/stop data into a parallel byte for processing by the controller.
14	GND	—	Ground reference (0 V)
15	\overline{PS}	I	This input controls the polarity of KDV and OH outputs. When left open or connected to V_{CC} , it forces the KDV and OH output to be active low. If this input is connected to ground, KDV and OH outputs are active high.

PIN NO.	PIN NAME	I/O	DESCRIPTION
16	WORD	I	When this input is open or connected to V_{CC} , the SC11008 sends result codes as words. When this input is low, result codes are sent as digits. This setting can also be changed by entering the V command.
17	$\overline{\text{RES EN}}$	I	When this input is low, the SC11008 sends result codes. When this input is high or left open, commands received from the terminal are performed but result codes are not sent. This setting can also be changed by entering the Q command.
18	ECHO EN	I	When this input is high or left open, the SC11008 echoes characters received from the terminal in the command state. When this input is low, the SC11008 won't echo characters unless it is set for half duplex and it is on line. This setting can also be changed by entering the E command.
19	$\overline{\text{AA DIS}}$	I	When this input is low, the SC11008 won't answer incoming calls. When this input is high or left open, the SC11008 automatically answers incoming calls on the first ring. This function can also be enabled/disabled by writing to the S0 register.
20	$\overline{\text{CMD EN}}$	I	When this input is low, the SC11008 recognizes commands sent to it. For some applications such as unattended answering operation it is better to disable this function by leaving this input open or connecting it to V_{CC} .
21	212A/ $\overline{\text{V.22}}$	I	When this input is open or connected to V_{CC} , the SC11008 supports Bell 103 and 212A modes. When this input is low, the SC11008 supports the CCITT V.22 and V.21 modes. This setting can also be changed by entering the B command.
22	MS SEL	I	When this input is open or connected to V_{CC} , the Mark/Space ratio is U.S. standard, 40/60 Make/Break. When it is low, the Mark/Space ratio is European standard, 33/67 Make/Break.
23	N.C.	—	No connection
24	$\overline{\text{HS}}$	O	This output, when low, indicates that the modem is in the high speed (1200 bps) mode. When high, it indicates that it is in the low speed (300 bps) mode. This output can be directly connected to a light emitting diode thru a 330 Ω resistor.
25	$\overline{\text{AA}}$	O	This output is low when the SC11008 is set for auto-answer mode, either by switch input $\overline{\text{AA DIS}}$ (pin 19) or register S0. The output goes high during each ring. If the device is not set to answer the phone (pin 19 is low or S0 = 0), this output goes low each time the phone rings. A light emitting diode thru a 330 Ω resistor can be directly connected to this output.
26	$\overline{\text{CD}}$	O	This output goes low when the SC11008 detects a carrier signal from the remote modem. If the connection is broken or never established, it remains high. A light emitting diode can be directly connected to this output thru a 330 Ω resistor.
27	$\overline{\text{DTR}}$	I	When this input is low, the SC11008 executes data call commands. If during a data call, this input goes high, the SC11008 terminates the data call, hangs up the phone line and returns to command state.
28	V_{CC}	—	Positive supply (+5 V)

Register	Range/Units	Description	Default
S0	0-255 rings	Ring to answer telephone on	0
S1	0-255 rings	Number of rings	0
S2	0-127 ASCII	Escape code character	43(+)
S3	0-127 ASCII	Character recognized as carriage return	13(CR)
S4	0-127 ASCII	Character recognized as line feed	10(LF)
S5	0-32, 127 ASCII	Character recognized as back space	8(BS)
S6	2-255 sec.	Wait time for dial tone	2
S7	1-255 sec.	Wait time for carrier	30
S8	0-255 sec.	Pause time (caused by comma)	2
S9	1-255 1/10 sec.	Carrier detect response time	6
S10	1-255 1/10 sec.	Delay between loss of carrier and hang up	7
S11	50-255 millisecond	Duration and spacing of Touch-Tones	70
S12	20-255 1/50 sec.	Escape code guard time	50
S13	bit mapped	UART status register	—
S14	bit mapped	Option register	—
S15	bit mapped	Flag register	—
S16	0,1,2,4	Test modes	0

Table 1. SC11008 S Registers (Software Registers) Used by AT Commands

Com- mand	Desc. (Notes 1 and 2)	Com- mand	Desc. (Notes 1 and 2)	Com- mand	Desc. (Notes 1 and 2)
Prefix, Repeat and Escape Commands		Other Commands		Other Commands	
AT	Attention prefix: precedes all command lines except + + + (escape) and A/(repeat) commands	A	Answer call without waiting for ring	O	Go to on-line state
A/	Repeat last command line (A/ is not followed by carriage return)	B/B0	CCITT V.22 mode (Note 3)	O1	Remote digital loopback off*
+ + +	Escape code: go from on-line state to command state (one second pause before and after escape code entry; + + + is not followed by carriage return)	B1	Bell 103 and 212A mode*	O2	Remote digital loopback request
Dialing Commands		C/C0	Transmit carrier off	Q/Q0	Result codes displayed*
D	Dial	C1	Carrier on*	Q1	Result codes not displayed
P	Pulse*	E/E0	Characters not echoed	Sr?	Requests current value of register r
T	Touch-Tone	E1	Characters echoed*	Sr=n	Sets register r to value of n
,	Pause	F/F0	Half duplex	V/V0	Digit result codes
!	Flash	F1	Full duplex*	V1	Word result codes*
/	Wait for 1/8 second	H/H0	On hook (hang up)	X/X0	Compatible with Hayes-type 300 modems*
@	Wait for silence	H1	Off hook, line and auxiliary relay	X1	Result code CONNECT 1200 enabled
W	Wait for second dial tone	H2	Off hook, line relay only	X2	Enables dial tone detection
;	Return to command state after dialing	I/I0	Request product ID code (130)	X3	Enables busy signal detection
R	Reverse mode (to call originate-only modem)	I1	Firmware revision number	X4	Enables dial tone and busy signal detection
		I2	Test internal memory	Y/Y0	Long space disconnect disabled*
		L/L1	Low speaker volume	Y1	Long space disconnect enabled
		L2	Medium speaker volume*	Z	Software reset: restores all default settings
		L3	High speaker volume		
		M/M0	Speaker always off		
		M1	Speaker on until carrier detected*		
		M2	Speaker always on		

- Notes: 1. Default Modes are indicated by *.
 2. Commands entered with null parameters assume 0-X is the same as X0.
 3. When used with the SC11014 or SC11015 modem IC, which has CCITT V.21 as well as V.22 modes, when the ATB command is used, in the answer mode, the SC11008 will put the SC11014 or SC11015 in either the V.21 mode or the V.22 mode, depending on the response from the remote modem. In the originate mode, the SC11008 will sense if the baud rate is set at 300 or 1200 bits per second and will adjust the SC11014 or SC11015 accordingly.

Table 2. Command Summary

Digit Code	Word Code	Description
0	OK	Command Executed
1	CONNECT	Connected at 300 or 1200 bps. Connected at 300 bps., if result of X1, X2, X3 or X4 command
2	RING	Ring signal detected (Note 1)
3	NO CARRIER	Carrier signal not detected or lost
4	ERROR	Illegal command Error in command line Command line exceeds buffer (40 character, including punctuation) Invalid character format at 1200 bps.
5	CONNECT 1200	Connected at 1200 bps. Results from X1, X2, X3, or X4 commands only
6	NO DIALTONE	Dialtone not detected and subsequent commands not processed. Results from X2 or X4 commands only.
7	BUSY	Busy signal detected and subsequent commands not processed. Results from X3 or X4 commands only.
8	NO ANSWER	Silence not detected and subsequent commands not processed. Results from @ command only.

Note 1. When the SC11008 detects a ringing on the telephone line, it sends a RING result code. However, the SC11008 will answer the call only if it is in auto-answer mode or is given an A command.

Table 3. Result Codes

ABSOLUTE MAXIMUM RATINGS (Note 1)

Supply Voltage, V_{CC}	+ 6 V
Input Voltage	-0.6V to $V_{CC}+0.6$
Storage temperature range	-65 to +150°C.
Maximum power dissipation @ 25°C.	500mW
Lead temperature (soldering, 10 sec)	300°C.
Operating temperature range	0 to 70°C.

Note 1. Absolute Maximum Ratings are those values beyond which the safety of the device cannot be guaranteed. Except for Operating temperature range, the device should not be operated at these limits. The Table of Electrical Characteristics provides actual operating limits.

DC ELECTRICAL CHARACTERISTICS

Param.	Description	Conditions	Min	Typ	Max	Units
V_{CC}	Positive Supply Voltage		4.5	5.0	5.5	V
I_{CC}	Operating Current	@ $V_{CC} = 5$ V, outputs unloaded		10.0		mA
V_{ih}	High Level Input Voltage	all pins except RI	2.0			V
V_{il}	Low Level Input Voltage	all pins except RI			0.8	V
V_{t+}	Positive hysteresis threshold	RI pin		2.5		V
V_{t-}	Negative hysteresis threshold	RI pin		1.8		V
V_{oh}	High Level Output Voltage	@ $I_{oh} = 2$ mA	$V_{CC} - 1.0$			V
V_{ol}	Low Level Output Voltage	@ $I_{oh} = 2$ mA			0.4	V
I_l	Leakage Current (Note 2)			±1.0		uA
f_{clk}	Clock frequency		7.37243	7.37280	7.37317	MHz

Note 2. This applies to all pins except TEST, \overline{WR} , \overline{RD} , SCK, DI/O and switch pins 15-21 which have internal pullups.

APPLICATIONS

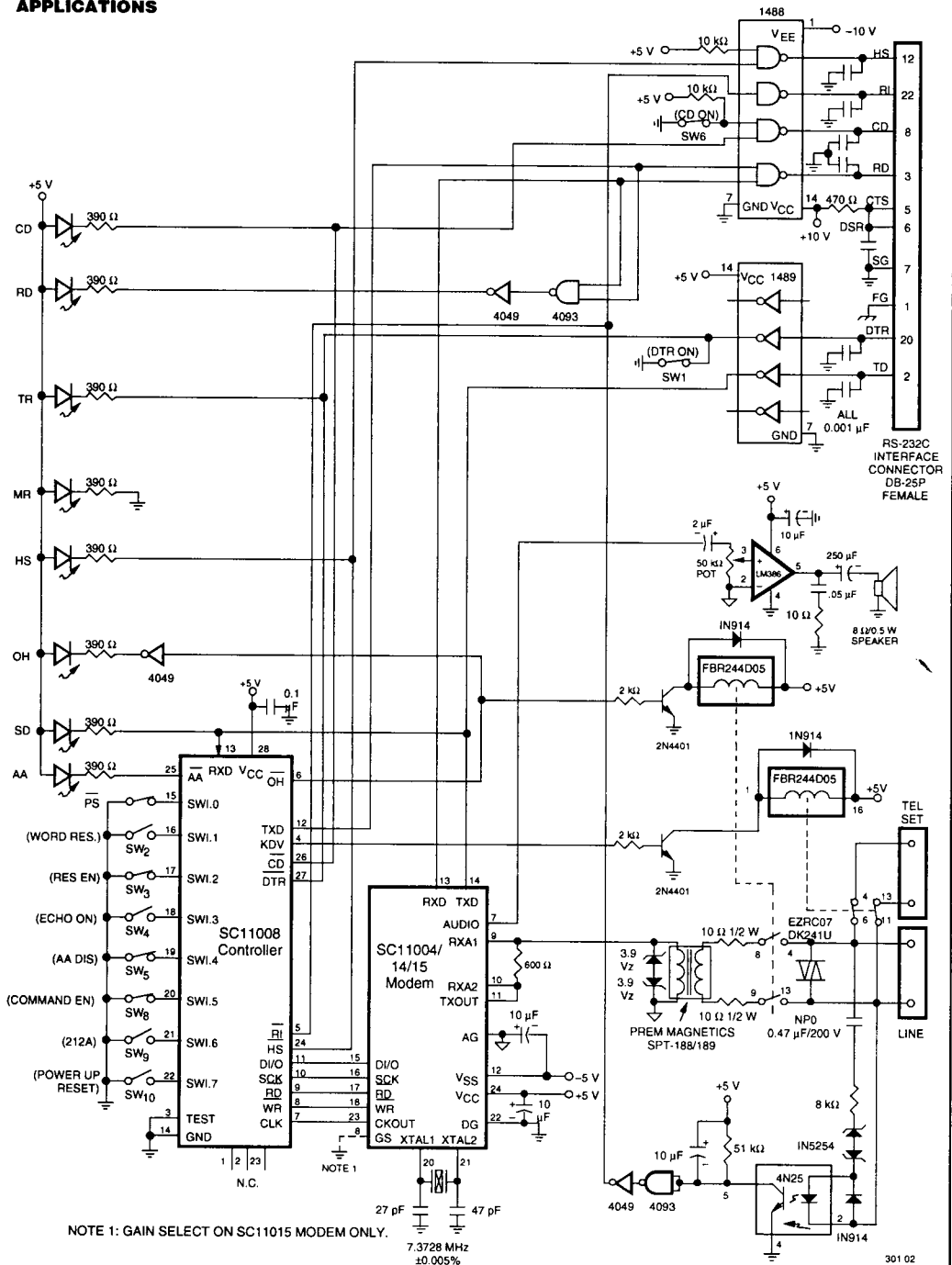

Figure 1. 212A/V.22 Stand-Alone Intelligent Modem Using the SC11004/14/15 Modem IC and the SC11008 Controller