

---

# 2SC2732

Silicon NPN Epitaxial

# HITACHI

---

## Application

UHF frequency converter

## Outline

MPAK

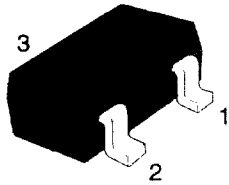

- 1. Emitter
- 2. Base
- 3. Collector

### Absolute Maximum Ratings (Ta = 25°C)

Item	Symbol	Ratings	Unit
Collector to base voltage	$V_{CBO}$	30	V
Collector to emitter voltage	$V_{CEO}$	25	V
Emitter to base voltage	$V_{EBO}$	4	V
Collector current	$I_C$	20	mA
Collector power dissipation	$P_C$	150	mW
Junction temperature	$T_j$	150	°C
Storage temperature	$T_{stg}$	-55 to +150	°C

### Electrical Characteristics (Ta = 25°C)

Item	Symbol	Min	Typ	Max	Unit	Test conditions
Collector to base breakdown voltage	$V_{(BR)CBO}$	30	—	—	V	$I_C = 10 \mu A, I_E = 0$
Collector to emitter breakdown voltage	$V_{(BR)CEO}$	25	—	—	V	$I_C = 1 \text{ mA}, R_{BE} = \infty$
Emitter to base breakdown voltage	$V_{(BR)EBO}$	4	—	—	V	$I_E = 10 \mu A, I_C = 0$
Collector cutoff current	$I_{CBO}$	—	—	0.5	$\mu A$	$V_{CB} = 10 \text{ V}, I_C = 0$
Collector to emitter saturation voltage	$V_{CE(sat)}$	—	—	5	V	$I_C = 10 \text{ mA}, I_B = 1 \text{ mA}$
DC current transfer ratio	$h_{FE}$	30	60	—		$V_{CE} = 10 \text{ V}, I_C = 3 \text{ mA}$
Gain bandwidth product	$f_T$	700	1000	—	MHz	$V_{CE} = 10 \text{ V}, I_C = 5 \text{ mA}$
Collector output capacitance	$C_{ob}$	—	0.5	0.8	pF	$V_{CB} = 10 \text{ V}, I_E = 0, f = 1 \text{ MHz}$
Conversion gain	CG	—	7.0	—	dB	$V_{CC} = 12 \text{ V}, I_C = 1 \text{ mA},$ $f = 900 \text{ MHz},$ $f_{osc} = 930 \text{ MHz (0dBm)},$ $f_{out} = 30 \text{ MHz}$
Noise figure	NF	—	10.0	—	dB	$V_{CC} = 12 \text{ V}, I_C = 1 \text{ mA},$ $f = 900 \text{ MHz},$ $f_{osc} = 930 \text{ MHz (0dBm)},$ $f_{out} = 30 \text{ MHz}$

Note: Marking is "EC".

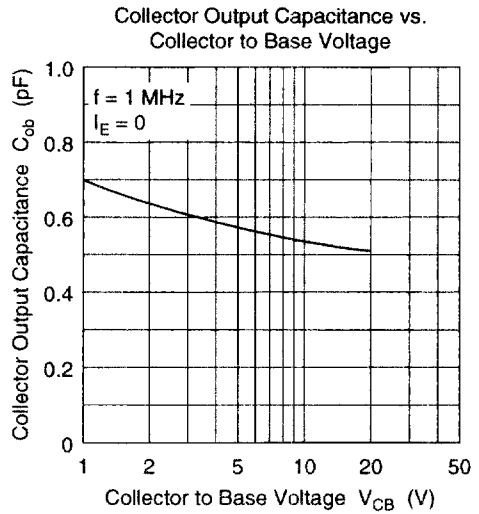
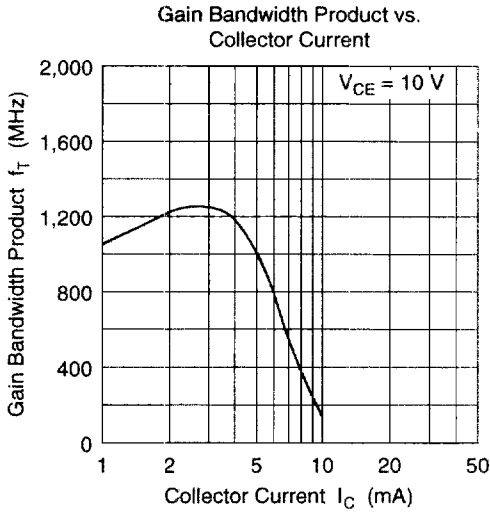
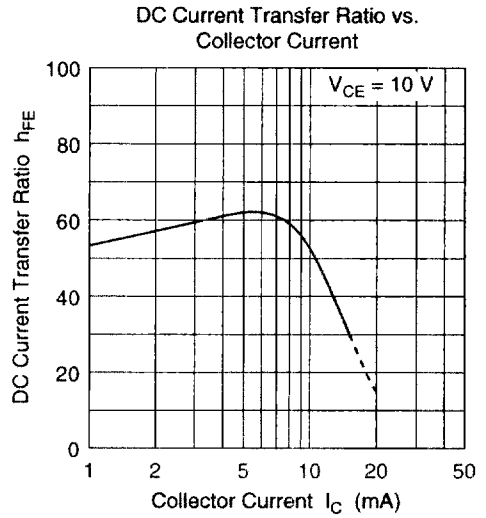
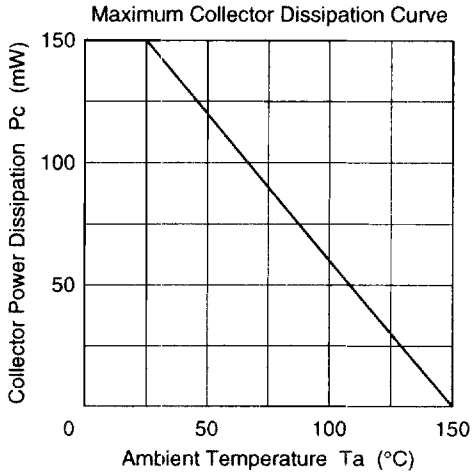

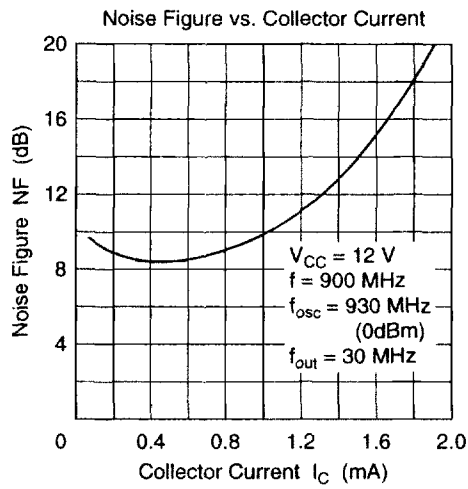
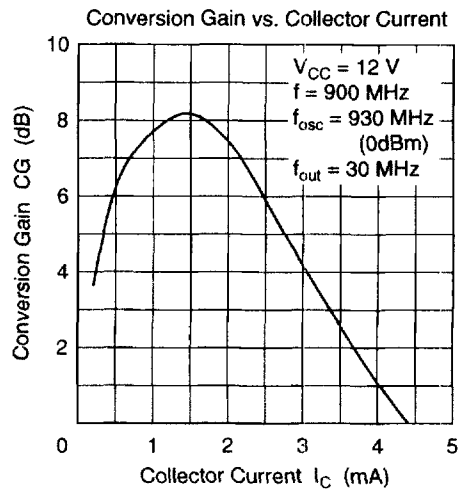
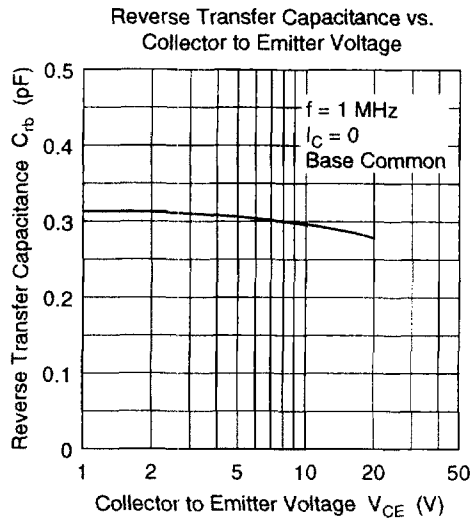

Conversion Gain, Noise Figure Test Circuit

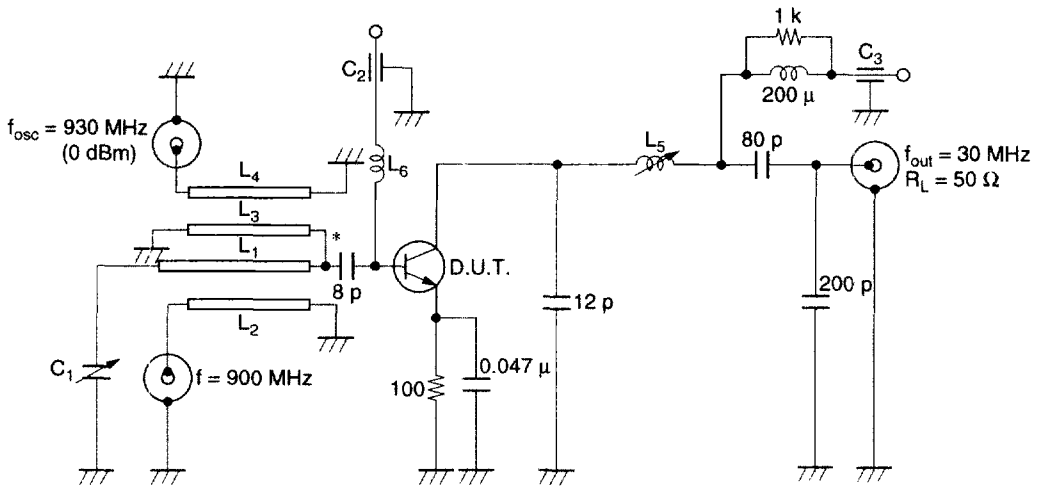

\*.....Disk Capacitor  
 Unit R :  $\Omega$   
 C : F  
 L : H

L<sub>1</sub> :  $\phi$ 1 mm Enameled Copper wire

L<sub>2</sub> :  $\phi$ 1 mm Enameled Copper wire

L<sub>3</sub> :  $\phi$ 1 mm Enameled Copper wire

L<sub>4</sub> :  $\phi$ 1 mm Enameled Copper wire

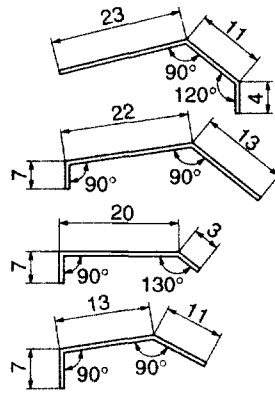

Unit : mm

L<sub>5</sub> : Bobbin  $\phi$ 0.5 mm inside dia,  $\phi$ 0.2 mm Enameled Copper wire 20 Turns

L<sub>6</sub> :  $\phi$ 5 mm Enameled Copper wire 1 Turns inside dia  $\phi$ 6 mm

C<sub>1</sub> : 20 pF max. Air Trimmer Condenser

C<sub>2</sub>, C<sub>3</sub> : 1000 pF Air Core Capacitor