

Through Hole Transformers Converter

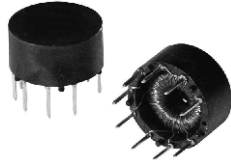

FEATURES

- Designed especially for low-power solid state circuits
- Designed for mounting on printed circuit boards
- Miniature size for minimum space
- High conversion efficiency from DC input to filtered DC output
- Compliant to RoHS directive 2002/95/EC



RoHS COMPLIANT

APPLICATIONS

Power supply for gas discharge display, battery-operated portable instruments, operational amplifier power supplies.

ELECTRICAL SPECIFICATIONS

Transformer Power Rating: 3 W
Isolation, Primary-Secondary: 500 V
 60 Hz. Operating characteristics may be varied to suit specific applications by appropriate selection of circuit components.

OPERATING TEMPERATURE RANGE:

- 20 °C to + 80 °C. Intended for use in enclosed commercial and industrial applications.

MECHANICAL SPECIFICATIONS

Coil: Secured to bottom of case with epoxy
Terminals: 0.025" [0.635 mm] square, solder plated

STANDARD ELECTRICAL SPECIFICATIONS						
MODEL	INPUT	OUTPUT	FREQ. REF. (kHz)	CIRCUIT EFF.	TEST CIRCUIT	SCHEMATIC NUMBER
TC-10-01B	3.6 V _{DC}	+ 7.2 ± 0.2 V _{DC} at 150 MW - 7.2 ± 0.2 V _{DC} at 150 MW	7.5	50 %	1	1
TC-10-02B	5 V _{DC}	200 ± 10 V _{DC} at 250 MW	11	50 %	2*	4
TC-10-03B	5 V _{DC}	200 ± 10 V _{DC} at 250 MW + 15 ± 0.4 V _{DC} at 125 MW - 15 ± 0.4 V _{DC} at 125 MW	11	60 %	2	2
TC-10-04B	5 V _{DC}	+ 15 ± 0.4 V _{DC} at 500 MW - 15 ± 0.4 V _{DC} at 500 MW	8	75 %	3	1
TC-10-05B	5 V _{DC}	+ 170 ± 5.1 V _{DC} at 850 MW + 32 ± 1.0 V _{DC} at 510 MW	11	75 %	4	5
TC-10-06B	5 V _{DC}	+ 35 ± 1.0 V _{DC} at 610 MW	11	70 %	4*	5*
TC-10-07B	7.5 V _{DC}	16.3 ± 0.4 V _{DC} at 330 MW	7	65 %	5	1
TC-10-08B	12 V _{DC}	± 15 ± 0.4 V _{DC} at 1 W	7.5	72 %	3	1
TC-10-09B	12 V _{DC}	160 ± 5 V _{DC} at 1.5 W	10	75 %	6	3
TC-10-10B	12 V _{DC}	14.2 ± 0.7 V _{DC} at 3 W	10	70 %	5	1
TC-10-11B	12 V _{DC}	+ 24 ± 0.5 V _{DC} at 2 W	10	80 %	5	1
TC-10-12B	24 V _{DC}	170 ± 5.1 V _{DC} at 850 MW 32 ± 1.0 V _{DC} at 510 MW	11	70 %	4	5

* Specifications relate to transformer when operated in applicable test circuit and at specified load power.

DIMENSIONS in inches [millimeters]

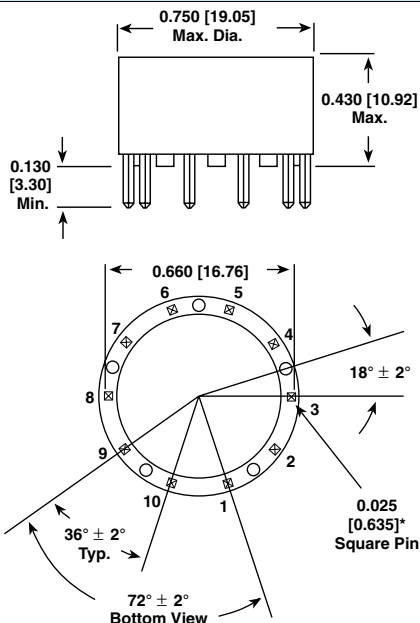

* Shows typical pin spacing. Pin #10 is omitted on all models except -05, -06, -12

SCHEMATICS

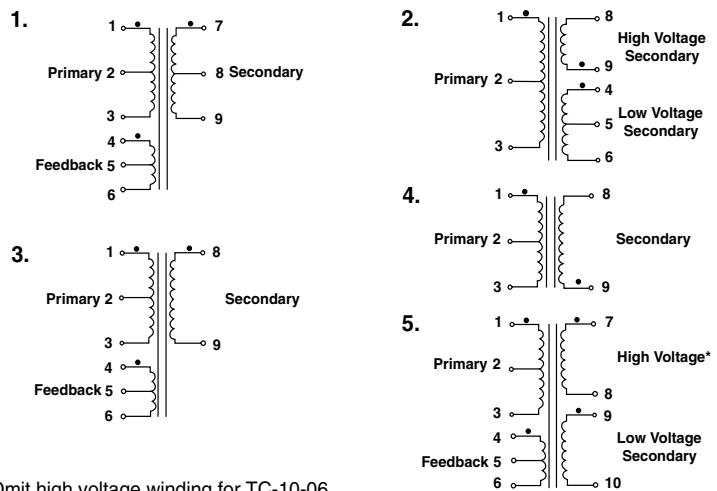

* Omit high voltage winding for TC-10-06

PART MARKING

- Model - Date code



ORDERING INFORMATION

TC-10	-01B	EB	e2
MODEL	DASH NUMBER	PACKAGE CODE	JEDEC LEAD (Pb)-FREE STANDARD

GLOBAL PART NUMBER

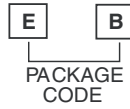
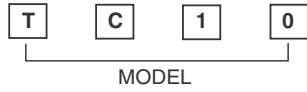



Disclaimer

All product specifications and data are subject to change without notice.

Vishay Intertechnology, Inc., its affiliates, agents, and employees, and all persons acting on its or their behalf (collectively, "Vishay"), disclaim any and all liability for any errors, inaccuracies or incompleteness contained herein or in any other disclosure relating to any product.

Vishay disclaims any and all liability arising out of the use or application of any product described herein or of any information provided herein to the maximum extent permitted by law. The product specifications do not expand or otherwise modify Vishay's terms and conditions of purchase, including but not limited to the warranty expressed therein, which apply to these products.

No license, express or implied, by estoppel or otherwise, to any intellectual property rights is granted by this document or by any conduct of Vishay.

The products shown herein are not designed for use in medical, life-saving, or life-sustaining applications unless otherwise expressly indicated. Customers using or selling Vishay products not expressly indicated for use in such applications do so entirely at their own risk and agree to fully indemnify Vishay for any damages arising or resulting from such use or sale. Please contact authorized Vishay personnel to obtain written terms and conditions regarding products designed for such applications.

Product names and markings noted herein may be trademarks of their respective owners.