



G2332

Microcircuits

NMOS 4096 X 8 ROM

Features

- 4096 8-bit bytes (32K)
- Maximum Active Current: 100 mA
- Max. access time: 350 nS—G2332-3
450 nS—G2332-4
- Output drive: one TTL load, plus 100 pF
- All input/outputs TTL compatible
- Two programmable Chip Select inputs
- Three-state outputs for memory expansion
- Single +5V power supply, ± 5 percent
- Standard 24-pin plastic or cerdip package

General Description

The GTE G2332 Read Only Memory is a 4096 word by 8 bit device with a maximum access time of 350 nanoseconds (G2332-3) or 450 nanoseconds (G2332-4). The G2332 ROM is a mask-programmable, byte-organized memory designed for use in bus-oriented applications with all 8-bit N-channel microprocessors. Dual Chip Select inputs provide convenient memory expansion—allowing up to four G2332 32K ROMs to be OR-tied without external coding. In addition, three-state output buffers allow simple parallel-busing for memory expansion. The G2332 is TTL compatible, requires only a single +5V power supply, requiring no external clocks and no refresh circuitry. Packaging is standard 24-pin plastic or cerdip.

Block Diagram

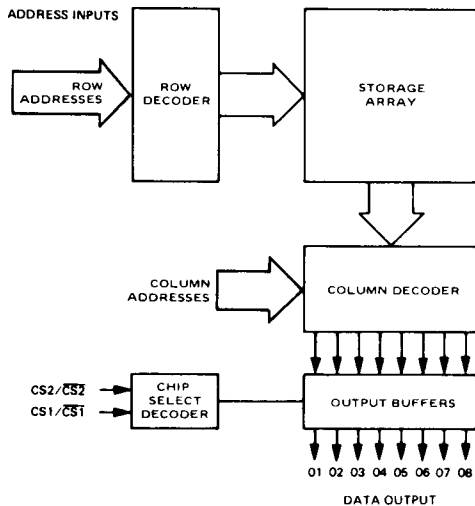

Pin Configuration

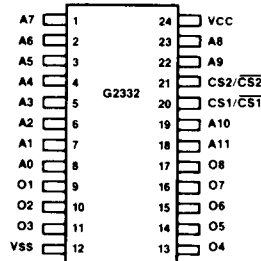

Pin Function

Pin	Description
A0-A11	Address
O1-O7	Outputs
Vcc	+5V
Vss	Ground
CS	Chip Select

Specifications

Device	Access Time	Max. Active Current	Package	Temp. Range
G2332-3CJ	350 nS	100 mA	Cerdip	0°C to 70°C
G2332-3CK	350 nS	100 mA	Plastic	0°C to 70°C
G2332-4CJ	450 nS	100 mA	Cerdip	0°C to 70°C
G2332-4CK	450 nS	100 mA	Plastic	0°C to 70°C

Absolute Maximum Ratings: (Note 1)

Parameter	Symbol	Value
Voltage to Any Pin With Respect to VSS	VDC	0.5V to 7.0V
Current Into/From Output	IDD	50 mA
Operation Ambient Temp. Range	TA	0°C to 70°C
Storage Temp. Range	TS	-65°C to 150°C

This device contains input protection against damage due to high static voltages or electric fields; however, precautions should be taken to avoid application of voltages higher than the maximum ratings.

NOTES:

- Exceeding these ratings may cause permanent damage, functional operation under these conditions is not implied.

DC Electrical Characteristics: Full Operating Voltage and Temperature Range

Characteristic	Symbol	Min	Max	Unit	Conditions
Input High Level	VIH	2.0	VCC	V	
Input Low Level	VIL	-0.5	+0.8	V	
Input Leakage Current	ILI	-10	+10	μA	
Output Leakage Current	ILO	-10	+10	μA	Vo = 0.4 to VCC
Output Voltage High	VOH	2.4	—	V	Io = -0.2 mA
Output Voltage Low	VOL	—	0.4	V	Io = 2.1 mA
Power Supply Current	ICC	—	100	mA	VCC = 5.25, TA = 0°C

Read Cycle—AC Characteristics: Full Operating Voltage and Temperature Range

Parameter	Symbol	G2332-3		G2332-4		Units
		Min	Max	Min	Max	
Read Cycle Time	tcyc	350	—	450	—	nS
Address Access Time	tACC	—	350	—	450	nS
Chip Select Delay Time	tCO	—	120	—	150	nS
Chip Deselect Delay Time	tDF	—	120	—	150	nS
Data Valid After Address Change	tOH	20	—	20	—	nS

Capacitance

Parameter	Symbol	Typ	Max	Unit	Conditions
Input Capacitance	CIN	4	7	pF	
Output Capacitance	COUT	5	10	pF	Vo = 0V

Timing Diagram
