

2.5 V and 3.3 V LVCMOS Clock Fanout Buffer

The MPC9456 is a 2.5 V and 3.3 V compatible 1:10 clock distribution buffer designed for low-voltage mid-range to high-performance telecom, networking and computing applications. Both 3.3 V, 2.5 V and dual supply voltages are supported for mixed-voltage applications. The MPC9456 offers 10 low-skew outputs and a differential LVPECL clock input. The outputs are configurable and support 1:1 and 1:2 output to input frequency ratios. The MPC9456 is specified for the extended temperature range of -40 to 85°C .

Features

- Configurable 10 outputs LVCMOS clock distribution buffer
- Compatible to single, dual and mixed 3.3 V/2.5 V voltage supply
- Wide range output clock frequency up to 250 MHz
- Designed for mid-range to high-performance telecom, networking and computer applications
- Supports high-performance differential clocking applications
- Maximum output skew of 200 ps (150 ps within one bank)
- Selectable output configurations per output bank
- Tristable outputs
- 32-lead LQFP package
- Ambient operating temperature range of -40 to 85°C
- 32-lead Pb-free package available

Functional Description

The MPC9456 is a full static design supporting clock frequencies up to 250 MHz. The signals are generated and retimed on-chip to ensure minimal skew between the three output banks.

Each of the three output banks can be individually supplied by 2.5 V or 3.3 V supporting mixed voltage applications. The FSELx pins choose between division of the input reference frequency by one or two. The frequency divider can be set individually for each of the three output banks. The MPC9456 can be reset and the outputs are disabled by deasserting the $\text{MR}/\overline{\text{OE}}$ pin (logic high state). Asserting $\text{MR}/\overline{\text{OE}}$ will enable the outputs.

All control inputs accept LVCMOS signals while the outputs provide LVCMOS compatible levels with the capability to drive terminated $50\ \Omega$ transmission lines. The clock input is low voltage PECL compatible for differential clock distribution support. Please consult the MPC9446 specification for a full CMOS compatible device. For series terminated transmission lines, each of the MPC9456 outputs can drive one or two traces giving the devices an effective fanout of 1:20. The device is packaged in a $7 \times 7\ \text{mm}^2$ 32-lead LQFP package.

MPC9456

**LOW VOLTAGE SINGLE OR DUAL
SUPPLY 2.5 V AND 3.3 V LVCMOS
CLOCK DISTRIBUTION BUFFER**



**FA SUFFIX
32-LEAD LQFP PACKAGE
CASE 873A-04**



**AC SUFFIX
32-LEAD LQFP PACKAGE
Pb-FREE PACKAGE
CASE 873A-04**

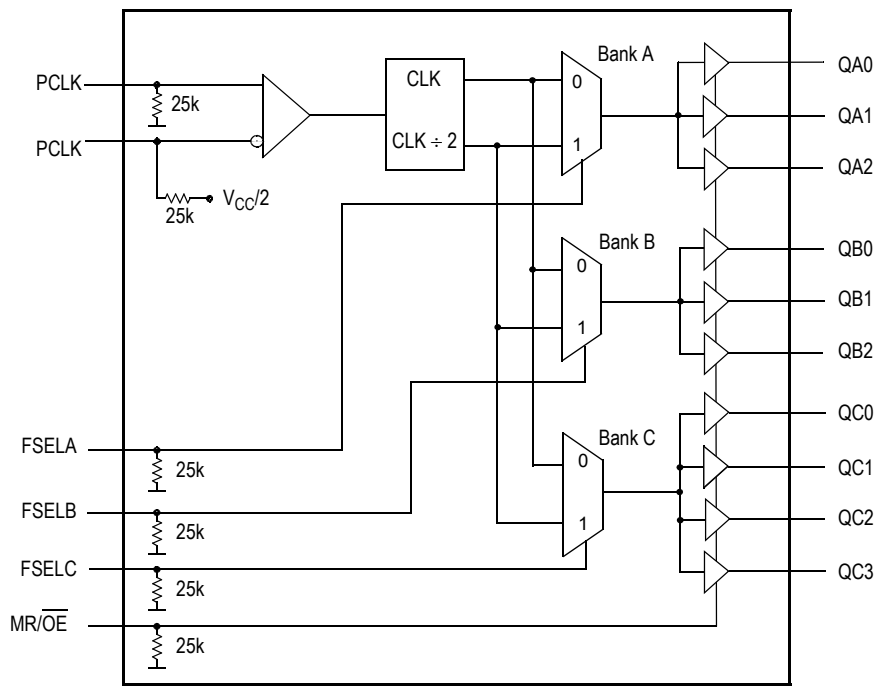

Figure 1. MPC9456 Logic Diagram

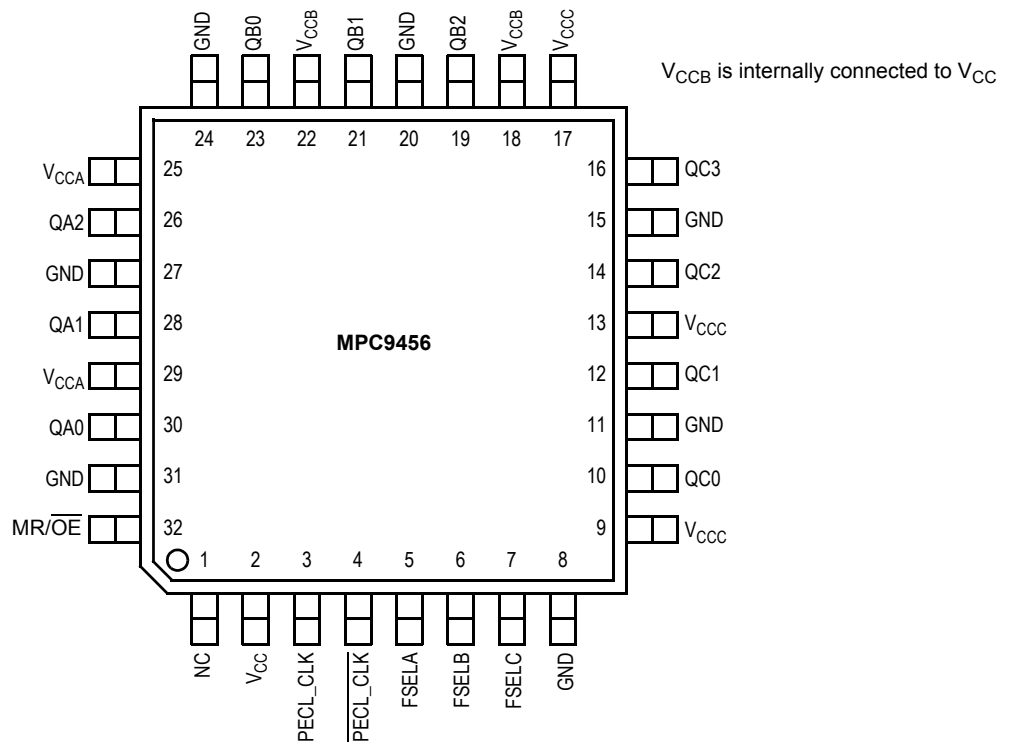

Figure 2. Pinout: 32-Lead Package Pinout (Top View)

Table 1. Pin Configuration

Pin	I/O	Type	Function
PECL_CLK, PECL_CLK	Input	LVPECL	Differential clock reference Low voltage positive ECL input
FSEL _A , FSEL _B , FSEL _C	Input	LVC MOS	Output bank divide select input
MR/OE	Input	LVC MOS	Internal reset and output tristate control
GND		Supply	Negative voltage supply output bank (GND)
V _{CCA} , V _{CCB} ⁽¹⁾ , V _{CCC}		Supply	Positive voltage supply for output banks
V _{CC}		Supply	Positive voltage supply core (VCC)
QA0 – QA2	Output	LVC MOS	Bank A outputs
QB0 – QB2	Output	LVC MOS	Bank B outputs
QC0 – QC3	Output	LVC MOS	Bank C outputs

1. V_{CCB} is internally connected to V_{CC}.

Table 2. Supported Single and Dual Supply Configurations

Supply Voltage Configuration	V _{CC} ⁽¹⁾	V _{CCA} ⁽²⁾	V _{CCB} ⁽³⁾	V _{CCC} ⁽⁴⁾	GND
3.3 V	3.3 V	3.3 V	3.3 V	3.3 V	0 V
Mixed Voltage Supply	3.3 V	3.3 V or 2.5 V	3.3 V	3.3 V or 2.5 V	0 V
2.5 V	2.5 V	2.5 V	2.5 V	2.5 V	0 V

- V_{CC} is the positive power supply of the device core and input circuitry. V_{CC} voltage defines the input threshold and levels.
- V_{CCA} is the positive power supply of the bank A outputs. V_{CCA} voltage defines bank A output levels.
- V_{CCB} is the positive power supply of the bank B outputs. V_{CCB} voltage defines bank B output levels. V_{CCB} is internally connected to V_{CC}.
- V_{CCC} is the positive power supply of the bank C outputs. V_{CCC} voltage defines bank C output levels.

Table 3. Function Table (Controls)

Control	Default	0	1
FSELA	0	f _{QA0:2} = f _{REF}	f _{QA0:2} = f _{REF} ÷ 2
FSELB	0	f _{QB0:2} = f _{REF}	f _{QB0:2} = f _{REF} ÷ 2
FSELC	0	f _{QC0:3} = f _{REF}	f _{QC0:3} = f _{REF} ÷ 2
MR/OE	0	Outputs enabled	Internal reset Outputs disabled (tristate)

Table 4. Absolute Maximum Ratings⁽¹⁾

Symbol	Characteristics	Min	Max	Unit	Condition
V _{CC}	Supply Voltage	-0.3	4.6	V	
V _{IN}	DC Input Voltage	-0.3	V _{CC} +0.3	V	
V _{OUT}	DC Output Voltage	-0.3	V _{CC} +0.3	V	
I _{IN}	DC Input Current		±20	mA	
I _{OUT}	DC Output Current		±50	mA	
T _S	Storage Temperature	-65	125	°C	

1. Absolute maximum continuous ratings are those maximum values beyond which damage to the device may occur. Exposure to these conditions or conditions beyond those indicated may adversely affect device reliability. Functional operation under absolute-maximum-rated conditions is not implied.

Table 5. General Specifications

Symbol	Characteristics	Min	Typ	Max	Unit	Condition
V _{TT}	Output Termination Voltage		V _{CC} ÷ 2		V	
MM	ESD Protection (Machine Model)	200			V	
HBM	ESD Protection (Human Body Model)	2000			V	
LU	Latch-Up Immunity	200			mA	
C _{PD}	Power Dissipation Capacitance		10		pF	Per output
C _{IN}	Input Capacitance		4.0		pF	

Table 6. DC Characteristics (V_{CC} = V_{CCA} = V_{CCB} = V_{CC3} = 3.3 V ± 5%, T_A = -40 to + 85°C)

Symbol	Characteristics	Min	Typ	Max	Unit	Condition
V _{IH}	Input High Voltage	2.0		V _{CC} +0.3	V	LVCMOS
V _{IL}	Input Low Voltage	-0.3		0.8	V	LVCMOS
V _{PP}	Peak-to-Peak Input Voltage	PCLK	250		mV	LVPECL
V _{CMR} ⁽¹⁾	Common Mode Range	PCLK	1.1	V _{CC} -0.6	V	LVPECL
I _{IN}	Input Current ⁽²⁾			200	µA	V _{IN} = GND or V _{IN} = V _{CC}
V _{OH}	Output High Voltage	2.4			V	I _{OH} = -24 mA ⁽³⁾
V _{OL}	Output Low Voltage			0.55 0.30	V V	I _{OL} = 24 mA ⁽²⁾ I _{OL} = 12 mA
Z _{OUT}	Output Impedance		14–17		Ω	
I _{CCQ} ⁽⁴⁾	Maximum Quiescent Supply Current			2.0	mA	All V _{CC} Pins

1. V_{CMR} (DC) is the crosspoint of the differential input signal. Functional operation is obtained when the crosspoint is within the V_{CMR} range and the input swing lies within the V_{PP} (DC) specification.
2. Input pull-up / pull-down resistors influence input current.
3. The MPC9456 is capable of driving 50 Ω transmission lines on the incident edge. Each output drives one 50 Ω parallel terminated transmission line to a termination voltage of V_{TT}. Alternatively, the device drives up to two 50 Ω series terminated transmission lines.
4. I_{CCQ} is the DC current consumption of the device with all outputs open and the input in its default state or open.

Table 7. AC Characteristics ($V_{CC} = V_{CCA} = V_{CCB} = V_{CCC} = 3.3\text{ V} \pm 5\%$, $T_A = -40$ to $+85^\circ\text{C}$)⁽¹⁾

Symbol	Characteristics	Min	Typ	Max	Unit	Condition	
f_{ref}	Input Frequency	0		250 ⁽²⁾	MHz		
f_{MAX}	Maximum Output Frequency	± 1 output ± 2 output	0 0	250 ⁽²⁾ 125	MHz MHz	FSELx = 0 FSELx = 1	
V_{PP}	Peak-to-Peak Input Voltage	PCLK	500	1000	mV	LVPECL	
$V_{\text{CMR}}^{(3)}$	Common Mode Range	PCLK	1.3	$V_{\text{CC}} - 0.8$	V	LVPECL	
$t_{\text{P, REF}}$	Reference Input Pulse Width		1.4		ns		
t_r, t_f	PCLK Input Rise/Fall Time			1.0 ⁽⁴⁾	ns	0.8 to 2.0 V	
t_{PLH} t_{PHL}	Propagation Delay	CCLK to any Q CCLK to any Q	2.2 2.2	2.8 2.8	4.45 4.2	ns ns	
$t_{\text{PLZ, HZ}}$	Output Disable Time			10	ns		
$t_{\text{PZL, LZ}}$	Output Enable Time			10	ns		
$t_{\text{sk(O)}}$	Output-to-Output Skew	Within one bank Any output bank, same output divider Any output, Any output divider		150 200 350	ps ps ps		
$t_{\text{sk(PP)}}$	Device-to-Device Skew			2.25	ns		
$t_{\text{sk(P)}}$	Output Pulse Skew ⁽⁵⁾			200	ps		
DC_Q	Output Duty Cycle	± 1 output ± 2 output	47 45	50 50	53 55	% %	$\text{DC}_{\text{REF}} = 50\%$ $\text{DC}_{\text{REF}} = 25\% - 75\%$
t_r, t_f	Output Rise/Fall Time		0.1		1.0	ns	0.55 to 2.4 V

- AC characteristics apply for parallel output termination of $50\ \Omega$ to V_{TT} .
- The MPC9456 is functional up to an input and output clock frequency of 350 MHz and is characterized up to 250 MHz.
- V_{CMR} (AC) is the crosspoint of the differential input signal. Normal AC operation is obtained when the crosspoint is within the V_{CMR} range and the input swing lies within the V_{PP} (AC) specification.
- Violation of the 1.0 ns maximum input rise and fall time limit will affect the device propagation delay, device-to-device skew, reference input pulse width, output duty cycle and maximum frequency specifications.
- Output pulse skew $t_{\text{sk(P)}}$ is the absolute difference of the propagation delay times: $|t_{\text{PLH}} - t_{\text{PHL}}|$. Output duty cycle is frequency dependent: $\text{DC}_Q = (0.5 \pm t_{\text{sk(P)}} \cdot f_{\text{OUT}})$. For example at $f_{\text{OUT}} = 125\text{ MHz}$ the output duty cycle limit is $50\% \pm 2.5\%$.

Table 8. DC Characteristics ($V_{CC} = V_{CCA} = V_{CCB} = V_{CCC} = 2.5\text{ V} \pm 5\%$, $T_A = -40$ to $+85^\circ\text{C}$)

Symbol	Characteristics	Min	Typ	Max	Unit	Condition
V_{IH}	Input high voltage	1.7		$V_{\text{CC}} + 0.3$	V	LVC MOS
V_{IL}	Input low voltage	-0.3		0.7	V	LVC MOS
V_{PP}	Peak-to-peak input voltage	PCLK	250		mV	LVPECL
$V_{\text{CMR}}^{(1)}$	Common Mode Range	PCLK	1.1	$V_{\text{CC}} - 0.7$	V	LVPECL
V_{OH}	Output High Voltage	1.8			V	$I_{\text{OH}} = -15\text{ mA}^{(2)}$
V_{OL}	Output Low Voltage			0.6	V	$I_{\text{OL}} = 15\text{ mA}$
Z_{OUT}	Output impedance		17–20 ⁽²⁾		Ω	
I_{IN}	Input current ⁽³⁾			± 200	μA	$V_{\text{IN}} = \text{GND}$ or $V_{\text{IN}} = V_{\text{CC}}$
$I_{\text{CCQ}}^{(4)}$	Maximum Quiescent Supply Current			2.0	mA	All V_{CC} Pins

- V_{CMR} (DC) is the crosspoint of the differential input signal. Functional operation is obtained when the crosspoint is within the V_{CMR} range and the input swing lies within the V_{PP} (DC) specification.
- The MPC9456 is capable of driving $50\ \Omega$ transmission lines on the incident edge. Each output drives one $50\ \Omega$ parallel terminated transmission line to a termination voltage of V_{TT} . Alternatively, the device drives up to two $50\ \Omega$ series terminated transmission lines per output.
- Input pull-up / pull-down resistors influence input current.
- CCQ is the DC current consumption of the device with all outputs open and the input in its default state or open.

Table 9. AC Characteristics ($V_{CC} = V_{CCA} = V_{CCB} = V_{CC} = 2.5 \text{ V} \pm 5\%$, $T_A = -40 \text{ to } +85^\circ\text{C}$)⁽¹⁾

Symbol	Characteristics	Min	Typ	Max	Unit	Condition	
f_{ref}	Input Frequency	0		250 ⁽²⁾	MHz		
f_{MAX}	Maximum Output Frequency	$\div 1$ output	0	250 ⁽²⁾	MHz	FSELx = 0	
		$\div 2$ output	0	125	MHz	FSELx = 1	
V_{PP}	Peak-to-Peak Input Voltage	PCLK	500	1000	mV	LVPECL	
V_{CMR} ⁽³⁾	Common Mode Range	PCLK	1.1	$V_{CC}-0.7$	V	LVPECL	
$t_{p, REF}$	Reference Input Pulse Width		1.4		ns		
t_r, t_f	PCLK Input Rise/Fall Time			1.0 ⁽⁴⁾	ns	0.7 to 1.7 V	
t_{PLH} t_{PHL}	Propagation Delay	PCLK to any Q	2.6	5.6	ns		
		PCLK to any Q	2.6	5.5	ns		
$t_{PLZ, HZ}$	Output Disable Time			10	ns		
$t_{PZL, LZ}$	Output Enable Time			10	ns		
$t_{sk(O)}$	Output-to-Output Skew	Within one bank		150	ps		
		Any output bank, same output divider		200	ps		
		Any output, Any output divider		350	ps		
$t_{sk(PP)}$	Device-to-Device Skew			3.0	ns		
$t_{sk(P)}$	Output Pulse Skew ⁽⁵⁾			200	ps		
DC_Q	Output Duty Cycle	$\div 1$ or $\div 2$ output	45	50	55	%	$DC_{REF} = 50\%$
t_r, t_f	Output Rise/Fall Time		0.1	1.0	ns	0.6 to 1.8 V	

- AC characteristics apply for parallel output termination of 50Ω to V_{TT} .
- The MPC9456 is functional up to an input and output clock frequency of 350 MHz and is characterized up to 250 MHz.
- V_{CMR} (AC) is the crosspoint of the differential input signal. Normal AC operation is obtained when the crosspoint is within the V_{CMR} range and the input swing lies within the V_{PP} (AC) specification.
- Violation of the 1.0 ns maximum input rise and fall time limit will affect the device propagation delay, device-to-device skew, reference input pulse width, output duty cycle and maximum frequency specifications.
- Output pulse skew $t_{sk(P)}$ is the absolute difference of the propagation delay times: $|t_{PLH} - t_{PHL}|$. Output duty cycle is frequency dependent: $DC_Q = (0.5 \pm t_{sk(P)} \cdot f_{OUT})$. For example at $f_{OUT} = 125 \text{ MHz}$ the output duty cycle limit is $50\% \pm 2.5\%$.

Table 10. AC Characteristics ($V_{CC} = 3.3 \text{ V} \pm 5\%$, $V_{CCA} = V_{CCB} = V_{CC} = 2.5 \text{ V} \pm 5\%$ or $3.3 \text{ V} \pm 5\%$, $T_A = -40 \text{ to } +85^\circ\text{C}$)^{(1), (2)}

Symbol	Characteristics	Min	Typ	Max	Unit	Condition	
$t_{sk(O)}$	Output-to-Output Skew	Within one bank		150	ps		
		Any output bank, same output divider		250	ps		
		Any output, Any output divider		350	ps		
$t_{sk(PP)}$	Device-to-Device Skew			2.5	ns		
$t_{PLH, HL}$	Propagation Delay	PCLK to any Q	See 3.3 V Table				
$t_{sk(P)}$	Output Pulse Skew ⁽³⁾			250	ps		
DC_Q	Output Duty Cycle	$\div 1$ or $\div 2$ output	45	50	55	%	$DC_{REF} = 50\%$

- AC characteristics apply for parallel output termination of 50Ω to V_{TT} .
- For all other AC specifications, refer to 2.5 V or 3.3 V tables according to the supply voltage of the output bank.
- Output pulse skew $t_{sk(P)}$ is the absolute difference of the propagation delay times: $|t_{PLH} - t_{PHL}|$. Output duty cycle is frequency dependent: $DC_Q = (0.5 \pm t_{sk(P)} \cdot f_{OUT})$.

APPLICATIONS INFORMATION

Driving Transmission Lines

The MPC9456 clock driver was designed to drive high speed signals in a terminated transmission line environment. To provide the optimum flexibility to the user the output drivers were designed to exhibit the lowest impedance possible. With an output impedance of less than 20 Ω the drivers can drive either parallel or series terminated transmission lines. For more information on transmission lines the reader is referred to application note AN1091. In most high performance clock networks point-to-point distribution of signals is the method of choice. In a point-to-point scheme either series terminated or parallel terminated transmission lines can be used. The parallel technique terminates the signal at the end of the line with a 50 Ω resistance to $V_{CC} \div 2$.

This technique draws a fairly high level of DC current and thus only a single terminated line can be driven by each output of the MPC9456 clock driver. For the series terminated case however there is no DC current draw, thus the outputs can drive multiple series terminated lines. Figure 3 illustrates an output driving a single series terminated line versus two series terminated lines in parallel. When taken to its extreme the fanout of the MPC9456 clock driver is effectively doubled due to its capability to drive multiple lines.

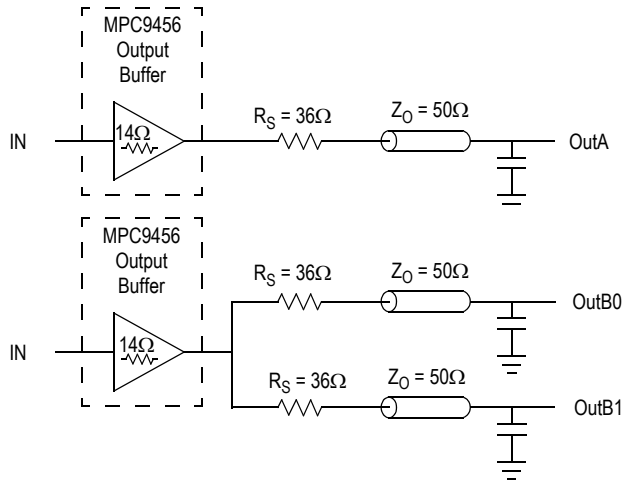

Figure 3. Single versus Dual Transmission Lines

The waveform plots in Figure 4 show the simulation results of an output driving a single line versus two lines. In both cases the drive capability of the MPC9456 output buffer is more than sufficient to drive 50 Ω transmission lines on the incident edge. Note from the delay measurements in the simulations a delta of only 43 ps exists between the two differently loaded outputs. This suggests that the dual line driving need not be used exclusively to maintain the tight output-to-output skew of the MPC9456. The output waveform in Figure 4 shows a step in the waveform, this step is caused by the impedance mismatch seen looking into the driver. The parallel combination of the 36 Ω series resistor plus the output impedance does not match the parallel combination of

the line impedances. The voltage wave launched down the two lines will equal:

$$V_L = V_S (Z_0 \div (R_S + R_0 + Z_0))$$

$$Z_0 = 50 \Omega \parallel 50 \Omega$$

$$R_S = 36 \Omega \parallel 36 \Omega$$

$$R_0 = 14 \Omega$$

$$V_L = 3.0 (25 \div (18 + 14 + 25)) \\ = 1.31 \text{ V}$$

At the load end the voltage will double, due to the near unity reflection coefficient, to 2.5 V. It will then increment towards the quiescent 3.0 V in steps separated by one round trip delay (in this case 4.0 ns).

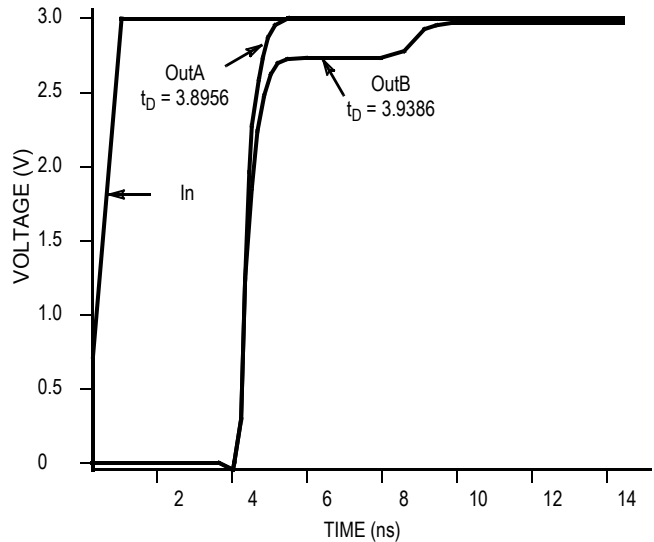

Figure 4. Single versus Dual Waveforms

Since this step is well above the threshold region it will not cause any false clock triggering, however designers may be uncomfortable with unwanted reflections on the line. To better match the impedances when driving multiple lines the situation in Figure 5 should be used. In this case the series terminating resistors are reduced such that when the parallel combination is added to the output buffer impedance the line impedance is perfectly matched.

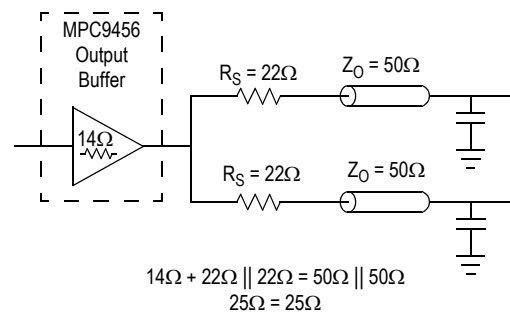

Figure 5. Optimized Dual Line Termination

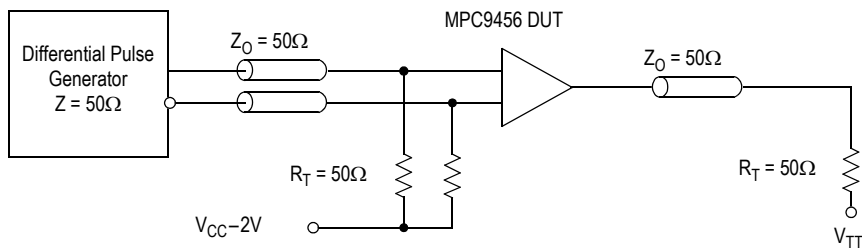

Figure 6. PCLK MPC9456 AC Test Reference for $V_{CC} = 3.3 \text{ V}$ and $V_{CC} = 2.5 \text{ V}$

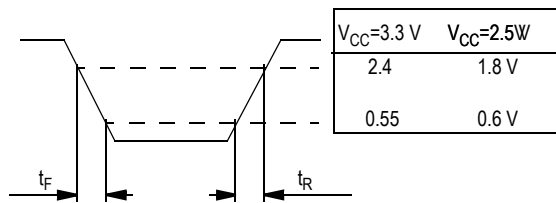

Figure 7. Output Transition Time Test Reference

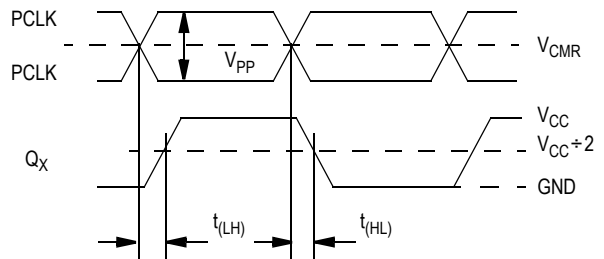
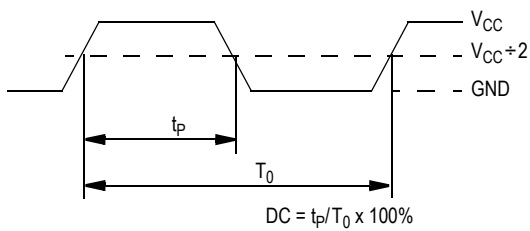
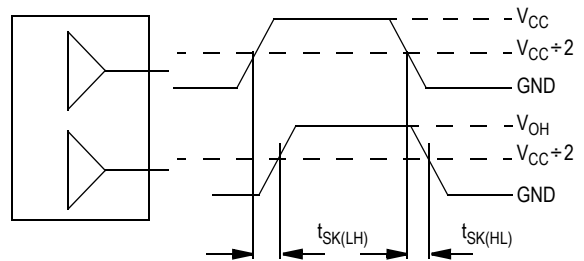

Figure 8. Propagation Delay (t_{PD}) Test Reference



The time from the PLL controlled edge to the non controlled edge, divided by the time between PLL controlled edges, expressed as a percentage

Figure 9. Output Duty Cycle (DC)



The pin-to-pin skew is defined as the worst case difference in propagation delay between any similar delay path within a single device

Figure 10. Output-to-Output Skew $t_{SK(O)}$

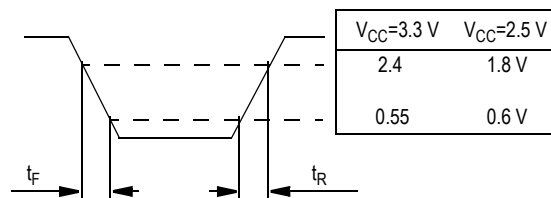
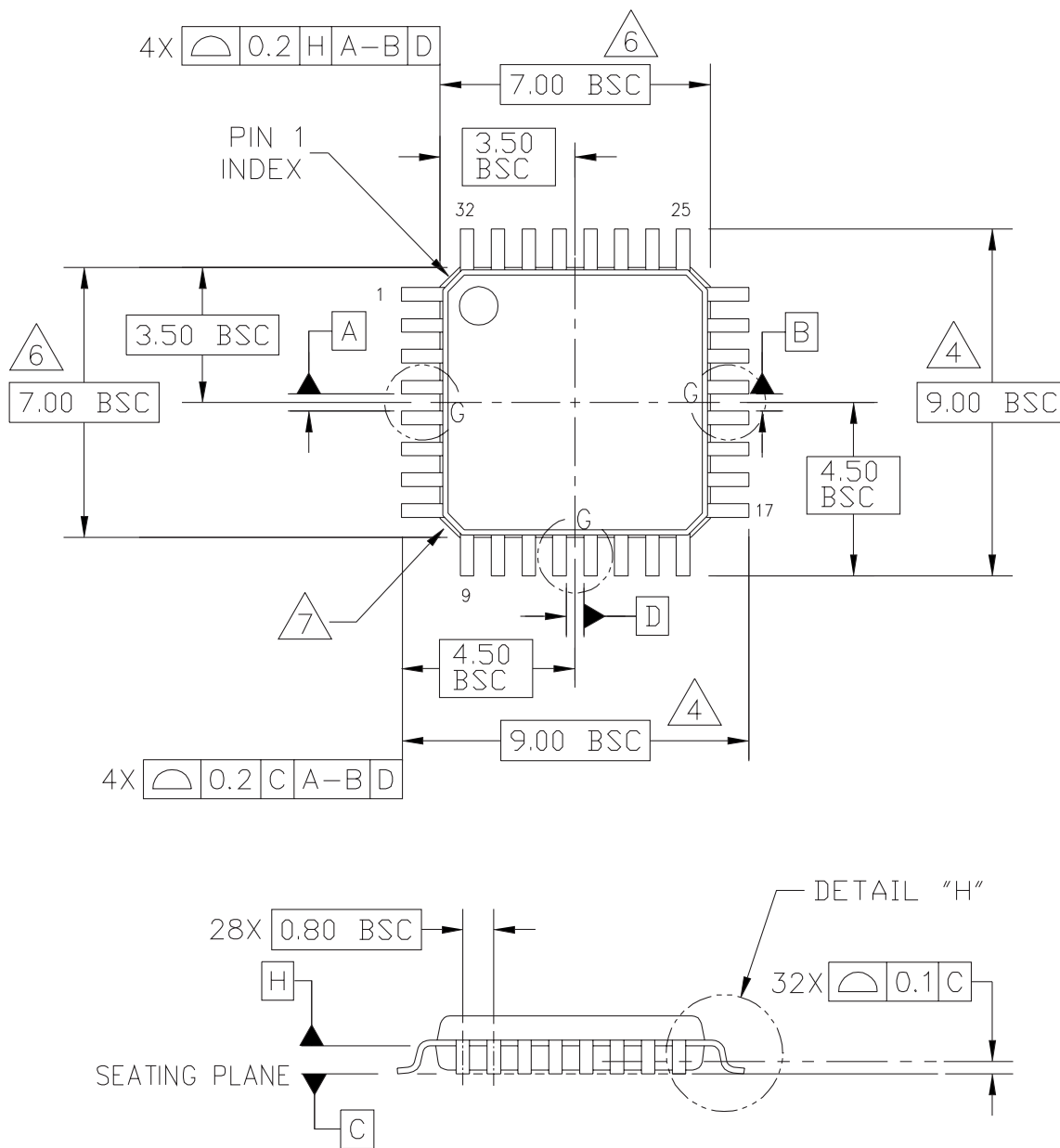

Figure 11. Output Transition Time Test Reference

PACKAGE DIMENSIONS



© FREESCALE SEMICONDUCTOR, INC. ALL RIGHTS RESERVED.	MECHANICAL OUTLINE	PRINT VERSION NOT TO SCALE	
TITLE: LOW PROFILE QUAD FLAT PACK (LQFP) 32 LEAD, 0.8 PITCH (7 X 7 X 1.4)	DOCUMENT NO: 98ASH70029A	REV: C	
	CASE NUMBER: 873A-04	01 APR 2005	
	STANDARD: JEDEC MS-026 BBA		

**CASE 873A-04
ISSUE C
32-LEAD LQFP PACKAGE**

PACKAGE DIMENSIONS

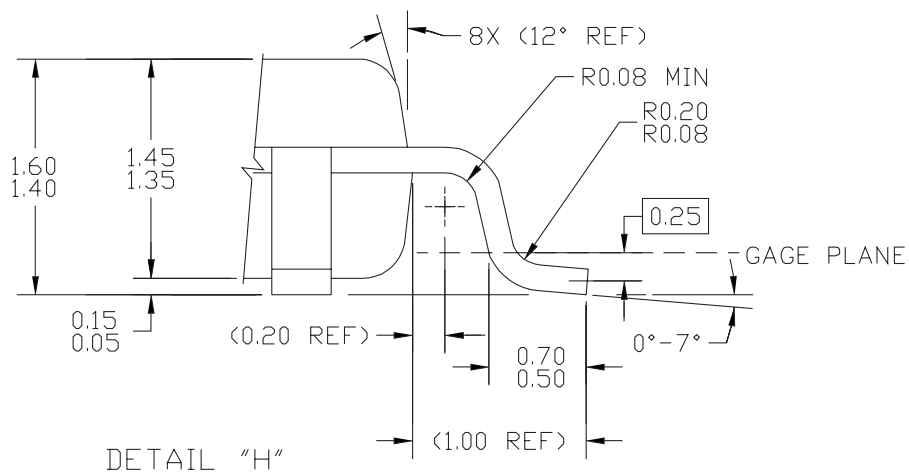
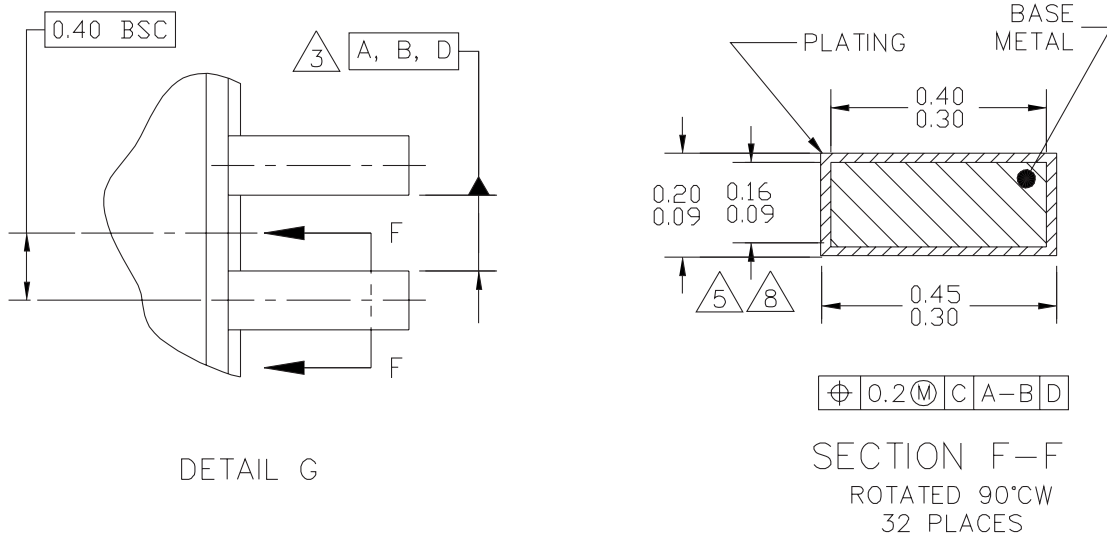

© FREESCALE SEMICONDUCTOR, INC. ALL RIGHTS RESERVED.	MECHANICAL OUTLINE	PRINT VERSION NOT TO SCALE	
TITLE: LOW PROFILE QUAD FLAT PACK (LQFP) 32 LEAD, 0.8 PITCH (7 X 7 X 1.4)	DOCUMENT NO: 98ASH70029A		REV: C
	CASE NUMBER: 873A-04		01 APR 2005
	STANDARD: JEDEC MS-026 BBA		

PAGE 2 OF 3

CASE 873A-04 ISSUE C 32-LEAD LQFP PACKAGE

PACKAGE DIMENSIONS

NOTES:

1. DIMENSIONS ARE IN MILLIMETERS.
2. INTERPRET DIMENSIONS AND TOLERANCES PER ASME Y14.5-1994.
3. DATUMS A, B, AND D TO BE DETERMINED AT DATUM PLANE H.
4. DIMENSIONS TO BE DETERMINED AT SEATING PLANE DATUM C.
5. DIMENSION DOES NOT INCLUDE DAMBAR PROTRUSION. ALLOWABLE DAMBAR PROTRUSION SHALL NOT CAUSE THE LEAD WIDTH TO EXCEED THE MAXIMUM DIMENSION BY MORE THAN 0.08 MM. DAMBAR CANNOT BE LOCATED ON THE LOWER RADIUS OR THE FOOT. MINIMUM SPACE BETWEEN PROTRUSION AND ADJACENT LEAD OR PROTRUSION: 0.07 MM.
6. DIMENSIONS DO NOT INCLUDE MOLD PROTRUSION. ALLOWABLE PROTRUSION IS 0.25 MM PER SIDE. DIMENSIONS ARE MAXIMUM PLASTIC BODY SIZE DIMENSIONS INCLUDING MOLD MISMATCH.
7. EXACT SHAPE OF EACH CORNER IS OPTIONAL.
8. THESE DIMENSIONS APPLY TO THE FLAT SECTION OF THE LEAD BETWEEN 0.1 MM AND 0.25 MM FROM THE LEAD TIP.

© FREESCALE SEMICONDUCTOR, INC. ALL RIGHTS RESERVED.	MECHANICAL OUTLINE	PRINT VERSION NOT TO SCALE
TITLE: LOW PROFILE QUAD FLAT PACK (LQFP) 32 LEAD, 0.8 PITCH (7 X 7 X 1.4)	DOCUMENT NO: 98ASH70029A	REV: C
	CASE NUMBER: 873A-04	01 APR 2005
	STANDARD: JEDEC MS-026 BBA	

PAGE 3 OF 3

**CASE 873A-04
ISSUE C
32-LEAD LQFP PACKAGE**

MPC9456

How to Reach Us:

Home Page:

www.freescale.com

E-mail:

support@freescale.com

USA/Europe or Locations Not Listed:

Freescale Semiconductor
Technical Information Center, CH370
1300 N. Alma School Road
Chandler, Arizona 85224
+1-800-521-6274 or +1-480-768-2130
support@freescale.com

Europe, Middle East, and Africa:

Freescale Halbleiter Deutschland GmbH
Technical Information Center
Schatzbogen 7
81829 Muenchen, Germany
+44 1296 380 456 (English)
+46 8 52200080 (English)
+49 89 92103 559 (German)
+33 1 69 35 48 48 (French)
support@freescale.com

Japan:

Freescale Semiconductor Japan Ltd.
Headquarters
ARCO Tower 15F
1-8-1, Shimo-Meguro, Meguro-ku,
Tokyo 153-0064
Japan
0120 191014 or +81 3 5437 9125
support.japan@freescale.com

Asia/Pacific:

Freescale Semiconductor Hong Kong Ltd.
Technical Information Center
2 Dai King Street
Tai Po Industrial Estate
Tai Po, N.T., Hong Kong
+800 2666 8080
support.asia@freescale.com

For Literature Requests Only:

Freescale Semiconductor Literature Distribution Center
P.O. Box 5405
Denver, Colorado 80217
1-800-441-2447 or 303-675-2140
Fax: 303-675-2150
LDCForFreescaleSemiconductor@hibbertgroup.com

Information in this document is provided solely to enable system and software implementers to use Freescale Semiconductor products. There are no express or implied copyright licenses granted hereunder to design or fabricate any integrated circuits or integrated circuits based on the information in this document.

Freescale Semiconductor reserves the right to make changes without further notice to any products herein. Freescale Semiconductor makes no warranty, representation or guarantee regarding the suitability of its products for any particular purpose, nor does Freescale Semiconductor assume any liability arising out of the application or use of any product or circuit, and specifically disclaims any and all liability, including without limitation consequential or incidental damages. "Typical" parameters that may be provided in Freescale Semiconductor data sheets and/or specifications can and do vary in different applications and actual performance may vary over time. All operating parameters, including "Typicals", must be validated for each customer application by customer's technical experts. Freescale Semiconductor does not convey any license under its patent rights nor the rights of others. Freescale Semiconductor products are not designed, intended, or authorized for use as components in systems intended for surgical implant into the body, or other applications intended to support or sustain life, or for any other application in which the failure of the Freescale Semiconductor product could create a situation where personal injury or death may occur. Should Buyer purchase or use Freescale Semiconductor products for any such unintended or unauthorized application, Buyer shall indemnify and hold Freescale Semiconductor and its officers, employees, subsidiaries, affiliates, and distributors harmless against all claims, costs, damages, and expenses, and reasonable attorney fees arising out of, directly or indirectly, any claim of personal injury or death associated with such unintended or unauthorized use, even if such claim alleges that Freescale Semiconductor was negligent regarding the design or manufacture of the part.

Freescale™ and the Freescale logo are trademarks of Freescale Semiconductor, Inc. All other product or service names are the property of their respective owners.

© Freescale Semiconductor, Inc. 2005. All rights reserved.

