

HN62444B Series

4M (256K x 16-bit) Mask ROM

DESCRIPTION

The Hitachi HN62444B is a 4-Megabit CMOS Mask Programmable Read Only Memory organized as 262,144 x 16 bit.

The low power consumption of this device makes it ideal for battery powered, portable systems. In addition, the high density and high speed provide enough capacity and high performance to be used as a character generator in laser printers.

Hitachi's HN62444B is offered with JEDEC-Standard pinouts in 40-pin Plastic DIP and 44-lead PLCC packages.

FEATURES

- Single Power Supply:
 $V_{CC} = 5V \pm 10\%$
- Fast Access Time:
 100 ns (max)
- Low Power Dissipation:
 Active Current: 150 mW (typ)
 Standby Current: 5 μ W (typ)
- TTL-Compatible Inputs and Outputs
- Three-State Data Outputs
- Pin Arrangements:
 JEDEC Standard Word-Wide EPROM Pinout
- Packages:
 40-pin Plastic DIP
 44-lead PLCC

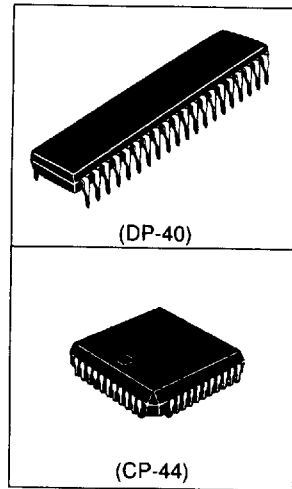

ORDERING INFORMATION

Type No.	Access Time	Package
HN62444BP	100 ns	40-pin Plastic DIP (DP-40)
HN62444BCP	100 ns	44-lead PLCC (CP-44)

BLOCK DIAGRAM

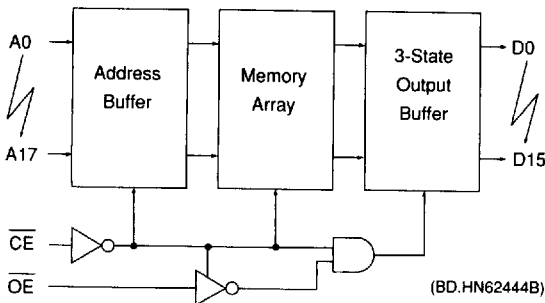

4496203 0025275 601

HITACHI

Hitachi America, Ltd. • 2000 Sierra Point Pkwy. • Brisbane, CA 94005-1819 • (415) 589-8300

HN62444B Series

PIN ARRANGEMENT

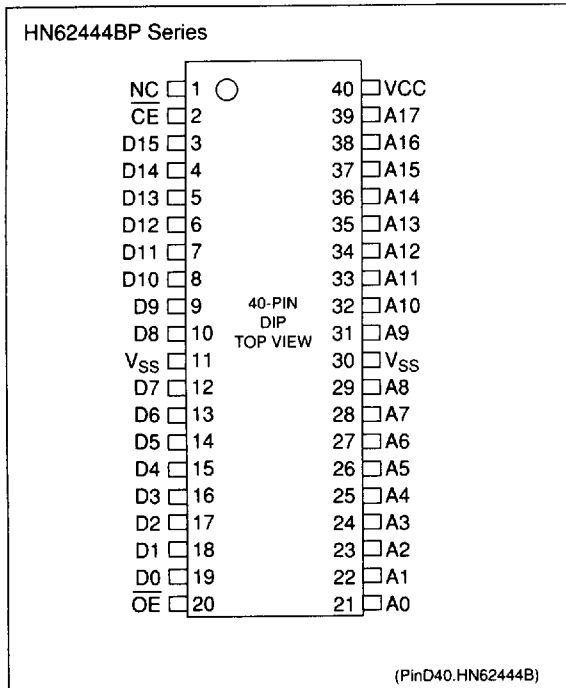

PIN DESCRIPTION

Pin Name	Function
$A_0 - A_{17}$	Address
$D_0 - D_{15}$	Output
\overline{CE}	Chip Enable
\overline{OE}	Output Enable
V_{CC}	Power Supply
V_{SS}	Ground
NC	No Connection

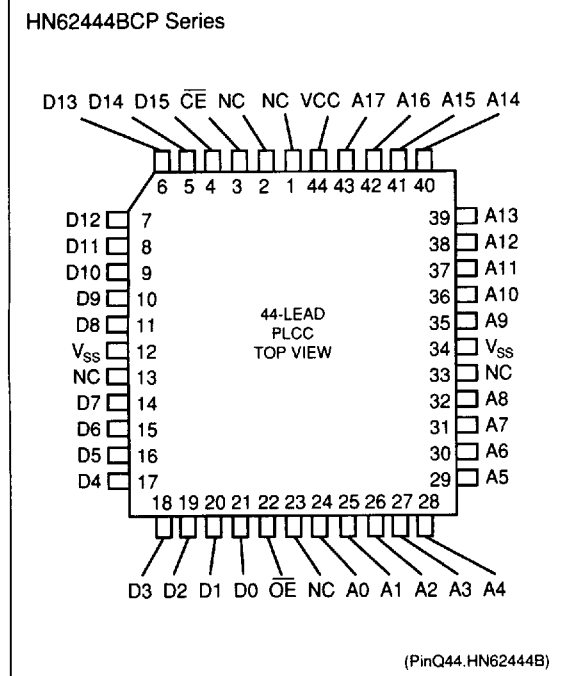

4496203 0025276 548

HITACHI

■ ABSOLUTE MAXIMUM RATINGS

Item	Symbol	Value	Unit
Supply Voltage ¹	V_{CC}	-0.3 to +7.0	V
All Input and Output Voltage ¹	V_T	-0.3 to $V_{CC} + 0.3$	V
Operating Temperature Range	T_{OPR}	0 to +70	°C
Storage Temperature Range	T_{STG}	-55 to +125	°C
Temperature Under Bias	T_{BIAS}	-20 to +85	°C

Note: 1. Relative to V_{SS} .

■ CAPACITANCE

($V_{CC} = 5V \pm 5\%$, $V_{SS} = 0V$, $T_a = 25^\circ C$, $V_{IN} = 0V$, $f = 1MHz$)

Item	Symbol	Min.	Typ.	Max.	Unit
Input Capacitance	C_{IN}	-	-	15	pF
Output Capacitance	C_{OUT}	-	-	15	pF

Note: 1. This parameter is sampled and not 100% tested.

■ DC ELECTRICAL CHARACTERISTICS FOR READ OPERATION

($V_{CC} = 5V \pm 5\%$, $V_{SS} = 0V$, $T_a = 0$ to $70^\circ C$)

Item	Symbol	Min.	Typ.	Max.	Unit	Test Condition
Input Leakage Current	I_{LI}	-	-	10	μA	$V_{IN} = 0$ to V_{CC}
Output Leakage Current	I_{LO}	-	-	10	μA	$\overline{CE} = 2.4$, $V_{OUT} = 0$ to V_{CC}
Operating V_{CC} Current	I_{CC}	-	-	100	mA	$V_{CC} = 5.5V$, $I_{DOUT} = 0$ mA, $t_{RC} = \text{min.}$
Standby V_{CC} Current	I_{SB1}	-	-	30	μA	$V_{CC} = 5.5V$, $\overline{CE} \geq V_{CC}$ to $-0.2V$
	I_{SB2}	-	-	3	mA	$V_{CC} = 5.5V$, $\overline{CE} \geq 2.4V$
Input Voltage	V_{IH}	2.4	-	$V_{CC} + 0.3$	V	
	V_{IL}	-0.3	-	0.45	V	
Output Voltage	V_{OH}	2.4	-	-	V	$I_{OH} = -400 \mu A$
	V_{OL}	-	-	0.4	V	$I_{OL} = 2.1$ mA

3

HN62444B Series

■ AC ELECTRICAL CHARACTERISTICS FOR READ OPERATION

($V_{CC} = 5V \pm 5\%$, $V_{SS} = 0V$, $T_a = 0$ to $70^\circ C$)

Test Conditions

- Input pulse levels: 0.45 / 2.4V
- Input rise and fall times: ≤ 10 ns
- Output load: 1 TTL Gate + $CL = 100$ pF (Including jig capacitance)
- Input/Output Timing Reference level: 1.5 V

Item	Symbol	HN62444B		Test Unit
		Min.	Max.	
Read Cycle Time	t_{RC}	100	-	ns
Address Access Time	t_{AA}	-	100	ns
Chip Enable Access Time	t_{ACE}	-	100	ns
Output Enable Access Time	t_{OE}	-	55	ns
Output Hold Time from Address Change	t_{DHA}	0	-	ns
Output Hold Time from Chip Enable	t_{DHC}	0	-	ns
Output Hold Time from Output Enable	t_{DHO}	0	-	ns
Chip Enable to Output in High-Z ¹	t_{CHZ}	-	40	ns
Output Enable to Output in High-Z ¹	t_{OHZ}	-	40	ns
Chip Enable to Output in Low-Z	t_{CLZ}	5	-	ns
Output Enable to Output in Low-Z	t_{OLZ}	5	-	ns

Note: 1. t_{CHZ} , t_{OHZ} are defined as the time at which the output becomes an open circuit and are not referred to output voltage levels.

■ READ TIMING WAVEFORM

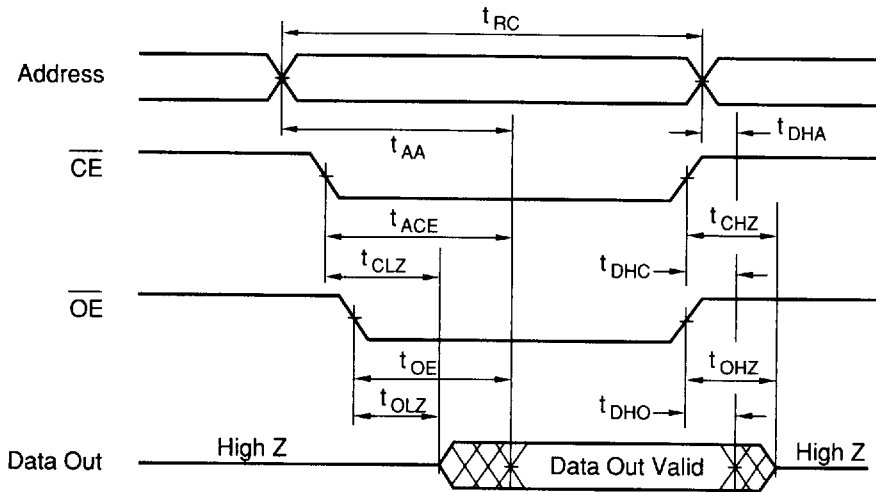

- Note:
1. t_{DHA} , t_{DHC} , t_{DHO} are determined by the faster time.
 2. t_{AA} , t_{ACE} , t_{OE} are determined by the slower time.
 3. t_{CLZ} , t_{OLZ} are determined by the slower time.

(TD.R.HN62444B)