

6

5

4

3

2

1

APPROVED: _____

DATE: _____ TITLE: _____

| Rev | AWO # | Description | Date | Appr |
|-----|---------|-------------|---------|------|
| - | AN15734 | RELEASED | 8/14/20 | |

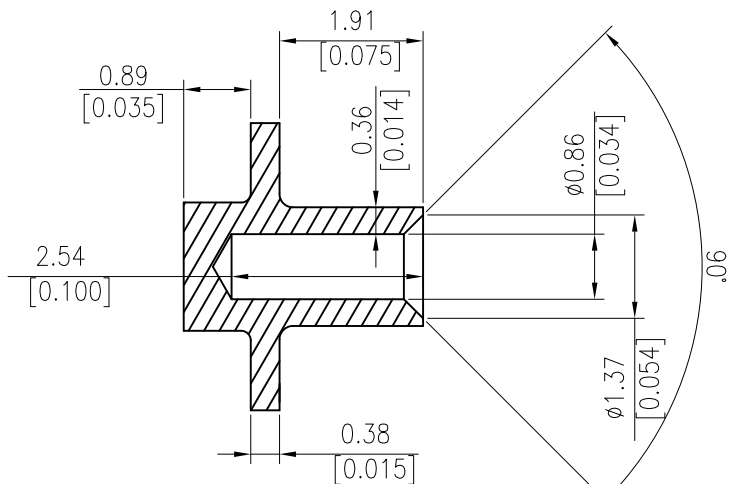

SCE A-A
SCALE 1:1

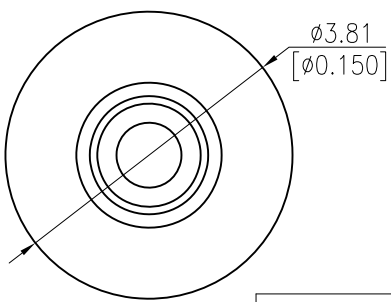
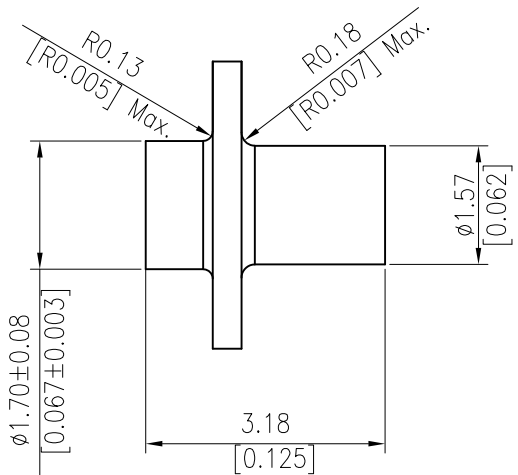

| Part No. | Material | Plating |
|--------------------|-------------|--|
| ADT-AN15734-1B-T/R | Brass C3601 | Tin plated 200u" Min., Nickel plating 100u" Min. overall. |
| ADT-AN15734-1S-T/R | Steel 12L14 | |

SPECIFICATIONS:

- MATERIAL: See Chart.
- FINISH: See Chart.
- MAXIMUM ALLOWABLE BURR HEIGHT SHALL NOT EXCEED 0.0005".
- PART TO BE FREE OF BURRS.
- ALL MATERIAL MUST BE COMPLY WITH RoHS.
- PACKING: TAPE & REEL.
- THE FOLLOWING INFORMATION TO BE ON SHIPPING CARTON LABEL:
Adam Tech name and address, Part description, PO, Customer P/N,
Material description, QTY, Country of origin and Date.

Environmental:
Lead free, RoHS compliant



UNLESS OTHERWISE SPECIFIED
ALL DIMENSIONS ARE MM [INCHES]
TOLERANCES: EXCEPT AS NOTED

| MM | ANGLE |
|--------------|-----------|
| .X ± 0.10 | .X ± 5° |
| .XX ± 0.076 | .XX ± 2° |
| .XXX ± 0.050 | .XXX ± 1° |

| APPROVALS | | DATE |
|-----------|----|---------|
| DRAWN | AY | 8/14/20 |
| CHECKED | EY | 8/14/20 |
| APPROVED | | |

ADAM TECH
INTERCONNECTS

909 Rahway Avenue,
Union, NJ 07083
Phone: 908-687-5000
Fax: 908-687-5710

| | | | |
|------------------------------|--------------------------------|--------------|--|
| TITLE CRIMP PIN 0.034" ID | | | |
| SIZE X | PART NO. ADT-AN15734-1X-T/R | REV. - | |
| REF: S00181C | SCALE: NTS | SHEET 1 OF 2 | |

6

5

4

3

2

1

6

5

4

3

2

1

APPROVED: _____

DATE: _____ TITLE: _____

| | | | | |
|-----|-------|-------------|------|------|
| Rev | AWO # | Description | Date | Appr |
|-----|-------|-------------|------|------|

SEE SHT 1 OF 2 FOR REVISION

PULL OUT DIRECTION REEL LABEL

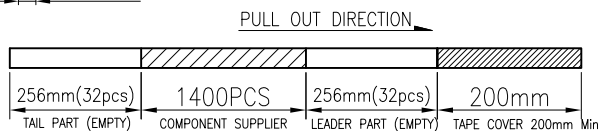
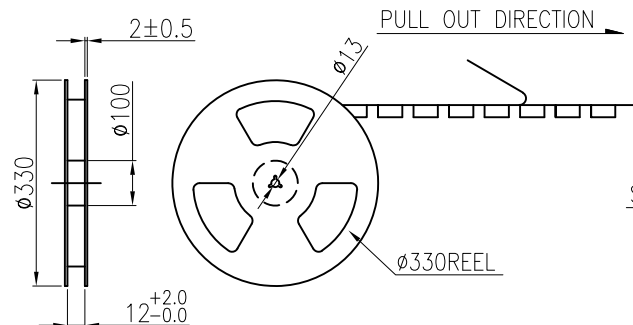
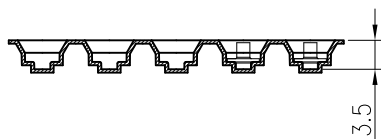
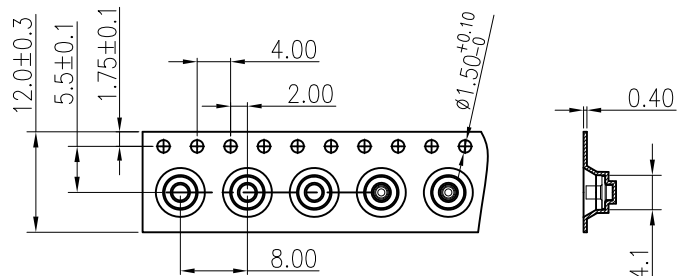

REEL LABEL

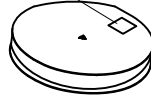

PAPERBOARD X2

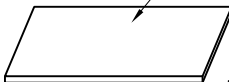

PE BAG X1

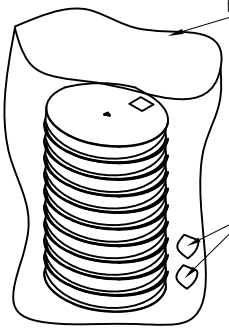

TOTAL 16 REELS

Desiccant X2

NOTES:

- MATERIAL:
 - TAPE: PS, T=0.50±0.05mm, BLACK, ESD
 - REEL: PS,
 - COVER TAPE: PE, CLEAR.
- PRIMARY PACKING: 1400PCS/REEL.
- SECONDARY PACKING: 22400PCS/16REEL/CARTON
- PEELING RESISTANCE: 0.2N(20gf)MIN; PEELING ANGLE: 165°~180°; PEELING SPEED: 300mm/minutes.

TABLE:

| | |
|--------------------|-------------|
| ADT-AN15734-1B-T/R | BRASS C3601 |
| ADT-AN15734-1S-T/R | STEEL 12L14 |
| PART NUMBER | MATERIAL |

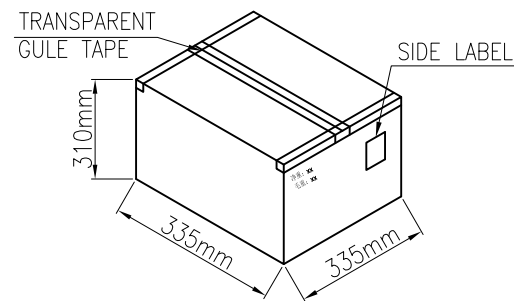

SET SQUARE X4

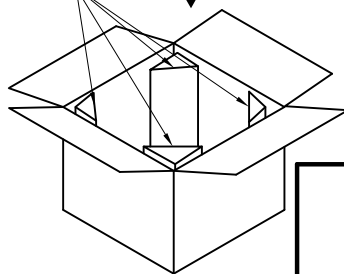

UNLESS OTHERWISE SPECIFIED
ALL DIMENSIONS ARE MM [INCHES]
TOLERANCES: EXCEPT AS NOTED

ADAM
TECH
INTERCONNECTS

909 Rahway Avenue,
Union, NJ 07083
Phone: 908-687-5000
Fax: 908-687-5710

| | | |
|-----------|----|---------|
| APPROVALS | | DATE |
| DRAWN | AY | 8/14/20 |
| CHECKED | EY | 8/14/20 |
| APPROVED | | |

| | | |
|---------------------|--------------------|--------------|
| TITLE | | |
| CRIMP PIN 0.034" ID | | |
| SIZE | PART NO. | REV. |
| X | ADT-AN15734-1X-T/R | - |
| REF: | S00181C | SCALE: NTS |
| | | SHEET 2 OF 2 |

6

5

4

3

2

1