



SANYO Semiconductors

DATA SHEET

LA8670M — Monolithic Linear IC Double-Conversion Narrow-Band FM IF System

Overview

The LA8670M is a narrow band FM IF system for use in communication equipment. In addition to the functions required for FM reception, the LA8670M provides a rich set of additional functions including noise detection and field strength detection, and is thus optimal for cordless telephones.

Functions

- First mixer, first local oscillator, first local oscillator buffer output, second mixer, second local oscillator
- IF amplifier, limiter, quadrature detector
- Signal meter
- Noise detector, noise amplifier, noise wave detector, schmitt trigger

Features

- Low voltage operation: $V_{CC\ op}=1.8$ to $6V$
- Signal meter linear over a wide range (70dB typical)
- High sensitivity, high intercept point

Specifications

Maximum Ratings at $T_a=25^\circ C$

Parameter	Symbol	Conditions	Ratings	Unit
Maximum supply voltage	$V_{CC\ max}$		7.0	V
Allowable power dissipation	$P_d\ max$	$T_a \leq 75^\circ C$	150	mW
Operating temperature	T_{opr}		-20 to +75	$^\circ C$
Storage temperature	T_{stg}		-40 to +125	$^\circ C$

Operating Conditions at $T_a=25^\circ C$

Parameter	Symbol	Conditions	Ratings	Unit
Recommended supply voltage	V_{CC}		3.0	V
Operating supply voltage	$V_{CC\ op}$		1.8 to 6.0	V

■ Any and all SANYO Semiconductor products described or contained herein do not have specifications that can handle applications that require extremely high levels of reliability, such as life-support systems, aircraft's control systems, or other applications whose failure can be reasonably expected to result in serious physical and/or material damage. Consult with your SANYO Semiconductor representative nearest you before using any SANYO Semiconductor products described or contained herein in such applications.

■ SANYO Semiconductor assumes no responsibility for equipment failures that result from using products at values that exceed, even momentarily, rated values (such as maximum ratings, operating condition ranges, or other parameters) listed in products specifications of any and all SANYO Semiconductor products described or contained herein.

LA8670M

Operating Characteristics at $T_a=25^\circ\text{C}$, $V_{CC}=3\text{V}$, $f_c(\text{MIX})=49.830\text{MHz}$, $f_{\text{mod}}=1\text{kHz}$, $\Delta f=\pm 3\text{kHz}$

Parameter	Symbol	Conditions	Ratings			Unit
			min	typ	max	
Quiescent current	I_{CCO}	No input		7.3	9.5	mA
Mixer intercept point	I_{p3}	First mixer		-4.8		dBm
12dB sensitivity	12dB S / N	No input matching		3.2	5.0	dB μ
Demodulator output	V_O	$V_{IN}=80\text{dB}\mu$	143	180	227	mVrms
Signal-to-noise ratio	S / N	No modulation, $V_{IN}=80\text{dB}\mu$	60	67		dB
AM rejection ratio	AMR	AM 30% modulation	35	43		dB
Total harmonic distortion	THD	$V_{IN}=80\text{dB}\mu$		2.2	3.0	%
Signal meter output	V_{SM1}	$V_{IN}=0\text{dB}\mu$	0.05	0.30	0.65	V
	V_{SM2}	$V_{IN}=40\text{dB}\mu$	0.60	0.90	1.40	V
	V_{SM3}	$V_{IN}=80\text{dB}\mu$	1.05	1.40	1.85	V
Noise detector output	V_{ND1}	$f_i=40\text{kHz}$, $V_i=-50\text{dBV}$		0.10	0.25	V
	V_{ND2}	$f_i=40\text{kHz}$, $V_i=-30\text{dBV}$	1.10	1.40	1.70	V
Noise detector level	V_{141}	Schmitt on	0.53	0.63	0.73	V
	V_{142}	Schmitt off	0.33	0.43	0.53	V
Schmitt output level	V_{SH1}	$V_{14}=0.8\text{V}$			0.3	V
	V_{SH2}	$V_{14}=0.2\text{V}$	2.8			V
Mixer conversion gain	G_{M1}	First mixer		19		dB
	G_{M2}	Second mixer		24		dB
Mixer input frequency					90	MHz
Mixer input resistance		First mixer		5		k Ω
		Second mixer		330		Ω
Mixer output resistance		First mixer		330		Ω
		Second mixer		2.0		k Ω
FM detector output impedance				520		Ω

Note: AC levels are all indicated for open (EMF) circuits.

Package Dimensions

unit : mm

3112B

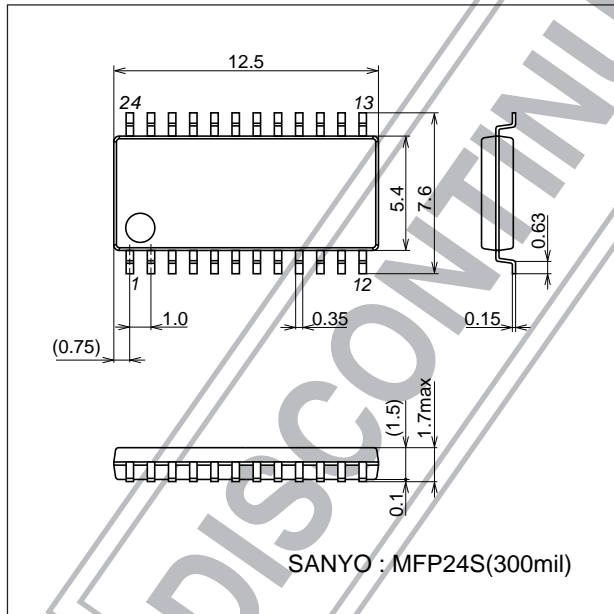

Equivalent Circuit Block Diagram

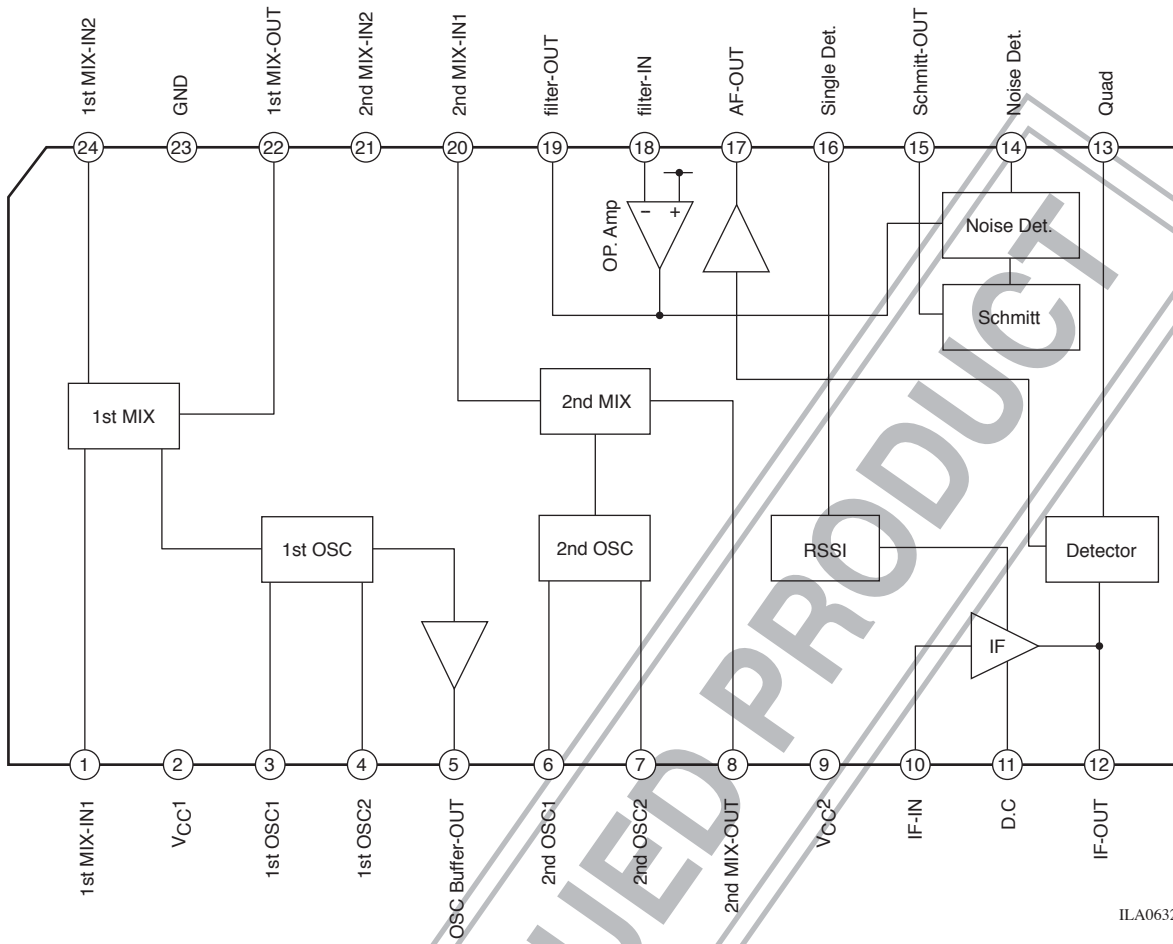

ILA06328

DISCONTINUED PRODUCT

Test Circuit

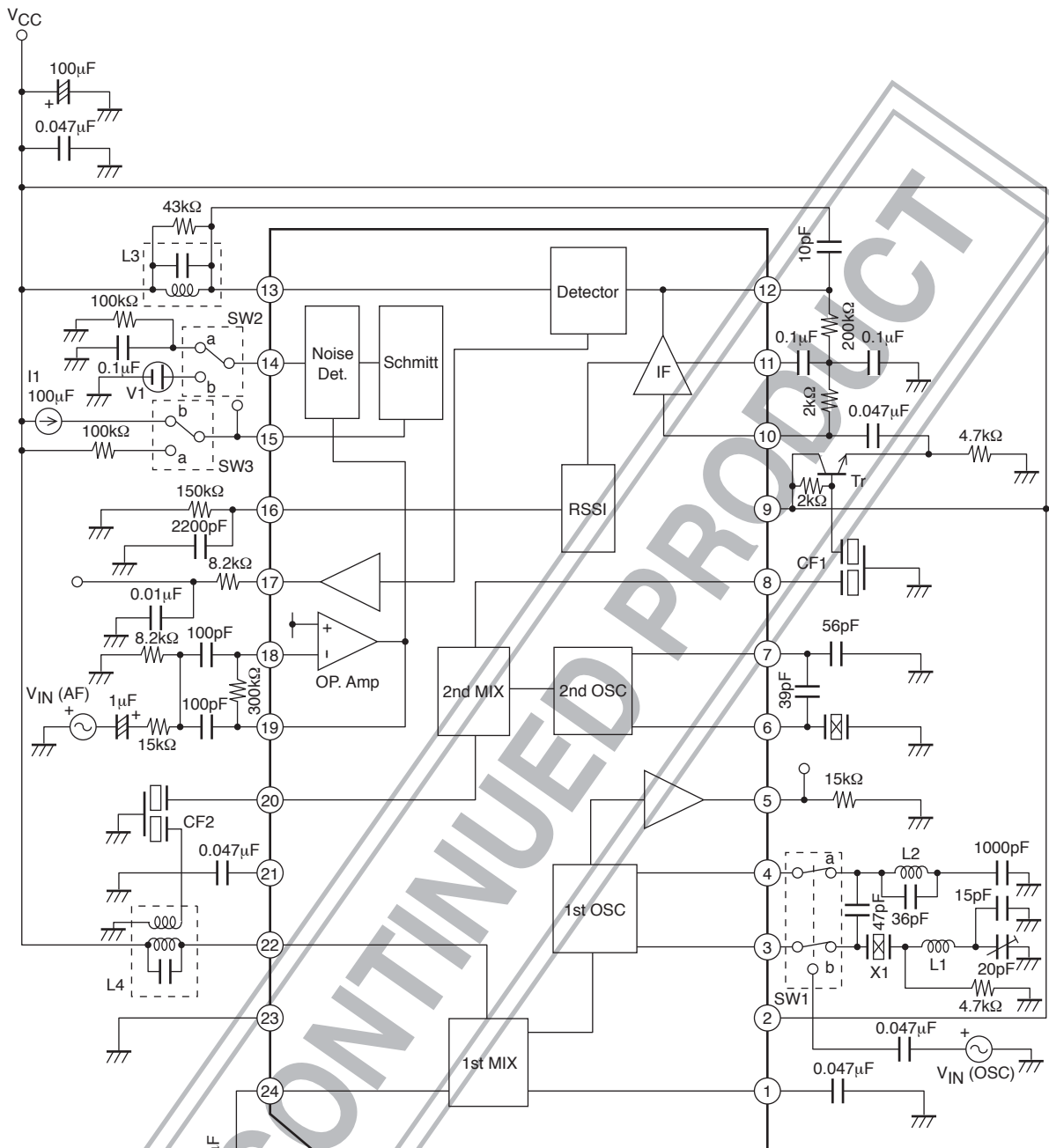

- CF1 □ CFW455F (Murata Mfg. Co., Ltd.)
- CF2 □ SFE10.7MS2 (Murata Mfg. Co., Ltd.)
- X1 □ 39.130MHz
- X2 □ 10.245MHz
- L1 □ 1.8μH
- L2 □ YD1002 (Mitsumi Electric. Co., Ltd.)
- L3 □ YD0051 (Mitsumi Electric. Co., Ltd.)
- L4 □ SA-246 (Sumida)
- Tr □ 2SC2999

ILA06329

LA8670M

Sample Application Circuit

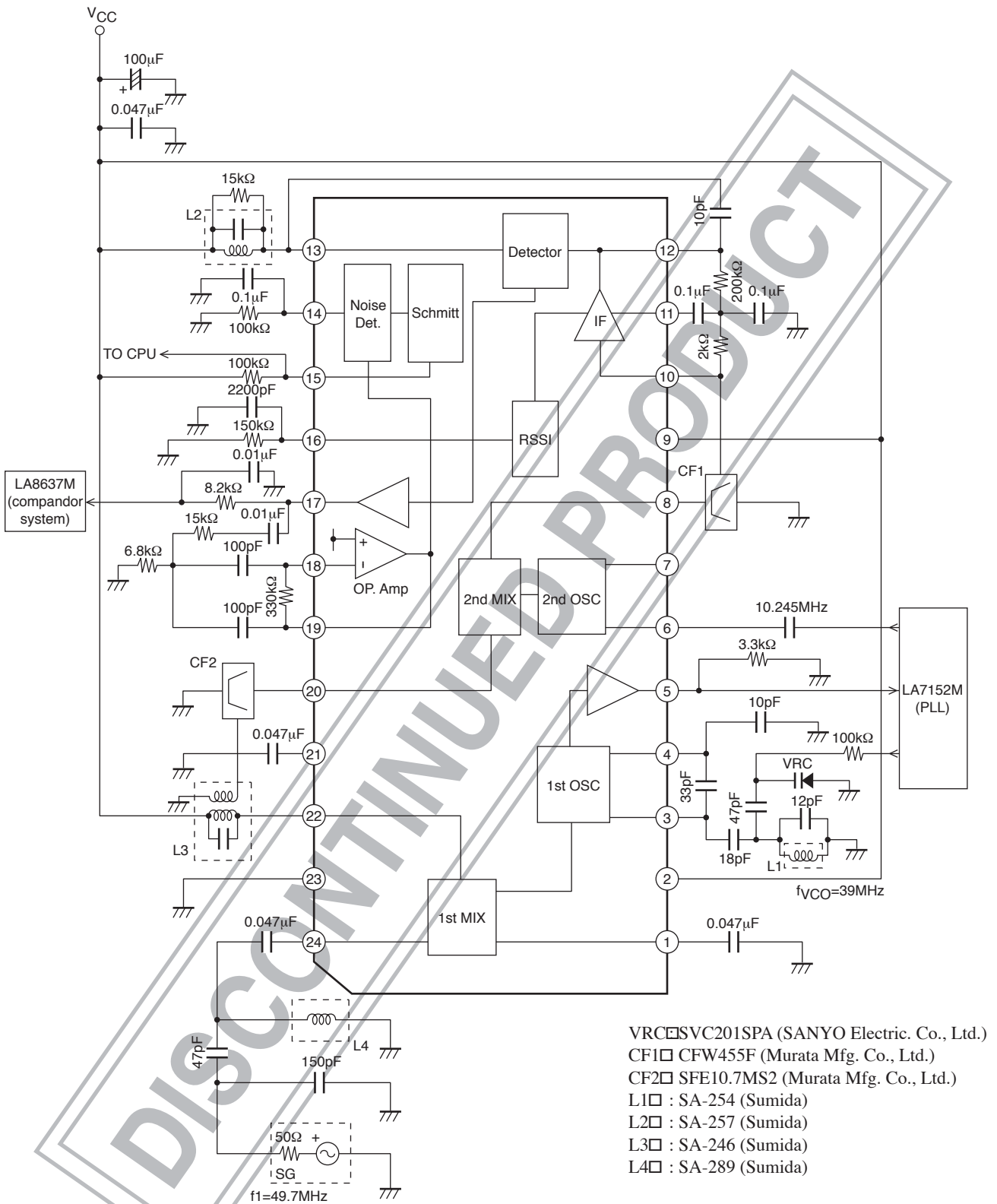

ILA06330

LA8670M

Pin Functions

Pin No.	Symbol	Internal equivalent circuit	Note
24	1st MIX-IN 2	<p>ILA06331</p>	First mixer inputs
1	1st MIX-IN 1		
2	VCC1		Power supply for the first mixer
3	1st OSC 1	<p>ILA06332</p>	Local oscillator inputs
4	1st OSC 2		
5	OSC Buffer-OUT		Local oscillator buffer output
6	2nd OSC 1	<p>ILA06333</p>	Local oscillator inputs When external insertion is used, input the signal to pin6 and leave pin7 open.
7	2nd OSC 2		
8	2nd MIX-OUT	<p>ILA06334</p>	Second mixer output
9	VCC2		Power supply
10	IF-IN	<p>ILA06335</p>	IF amplifier input
11	D.C		IF amplifier DC feedback
12	IF-OUT	<p>ILA06336</p>	Limiter amplifier output

Continued on next page.

LA8670M

Continued from preceding page.

Pin No.	Symbol	Internal equivalent circuit	Note
13	Quad.	<p style="text-align: right;">ILA06337</p>	Discriminator connection
14	Noise det.	<p style="text-align: right;">ILA06338</p>	Noise detector
15	Schmitt-OUT	<p style="text-align: right;">ILA06339</p>	Noise Schmitt output
16	Signal DET.	<p style="text-align: right;">ILA06340</p>	Field strength signal output
17	AF-OUT	<p style="text-align: right;">ILA06341</p>	FM detector output
18	Filter-IN	<p style="text-align: right;">ILA06342</p>	Noise filter input
19	Filter-OUT		Noise filter output
20	2nd MIX-IN 1	<p style="text-align: right;">ILA06343</p>	Second mixer input
21	2nd MIX-IN 2		

Continued on next page.

LA8670M

Continued from preceding page.

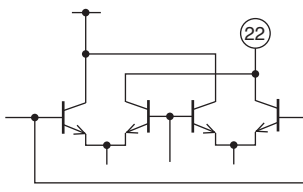
Pin No.	Symbol	Internal equivalent circuit	Note
22	1st MIX-OUT	 <p>ILA06344</p>	First mixer output
23	GND		Ground

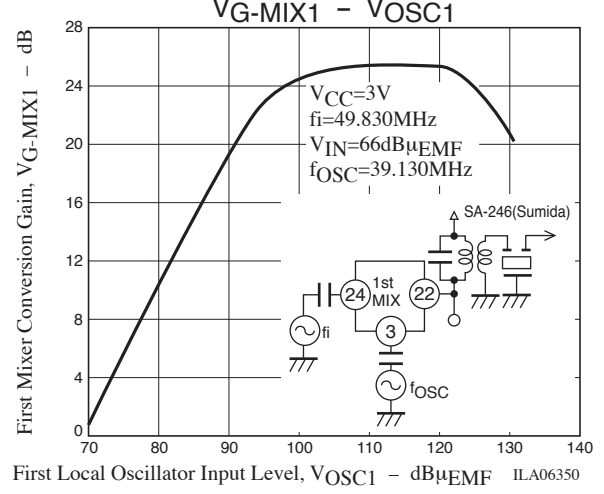
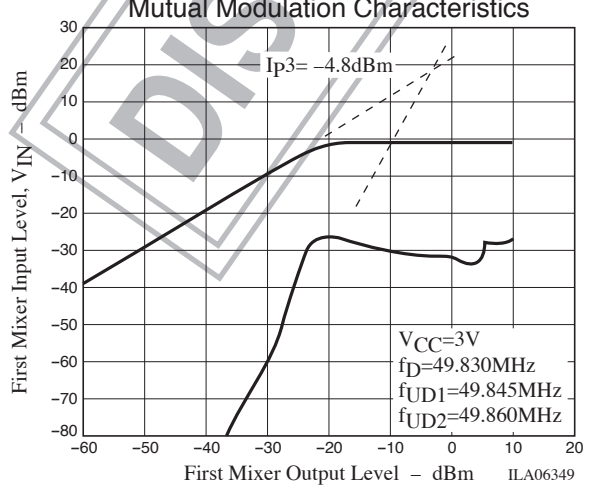
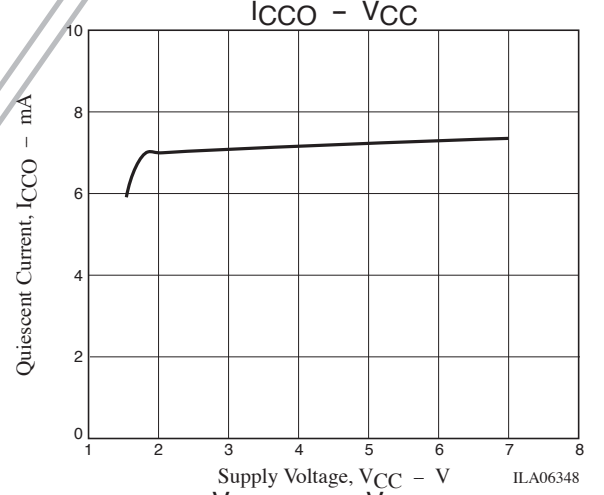
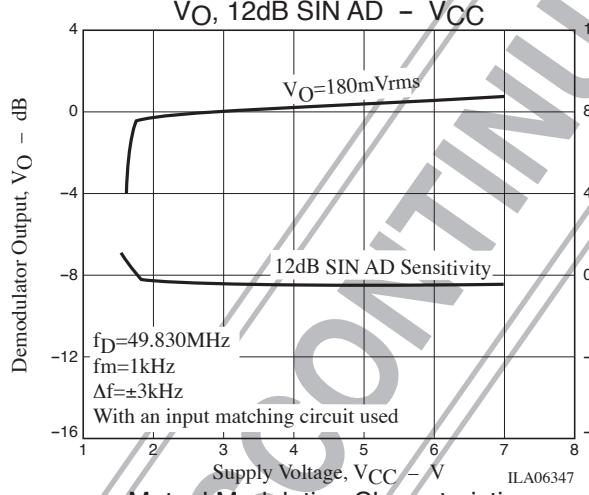
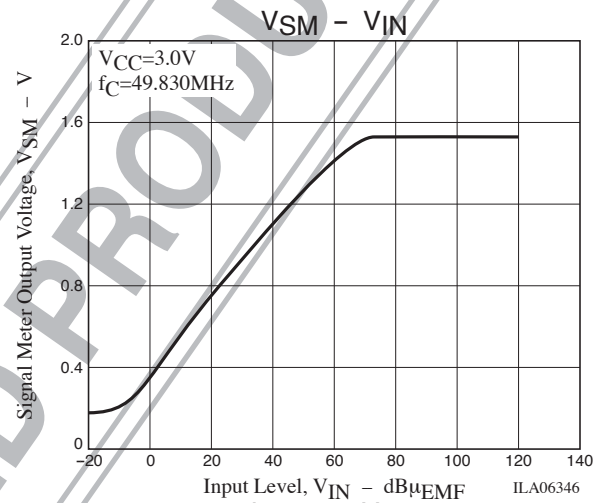
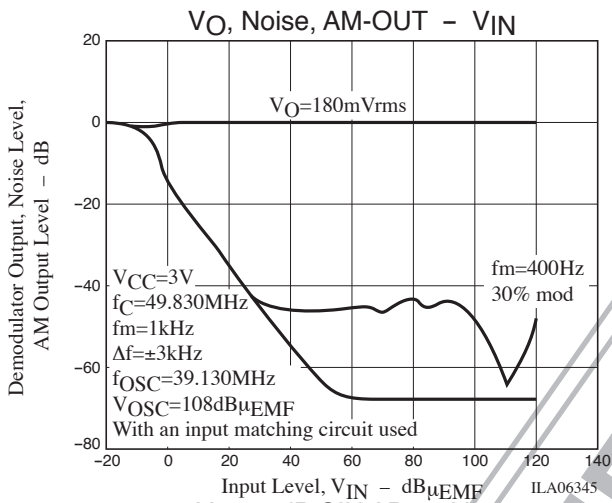

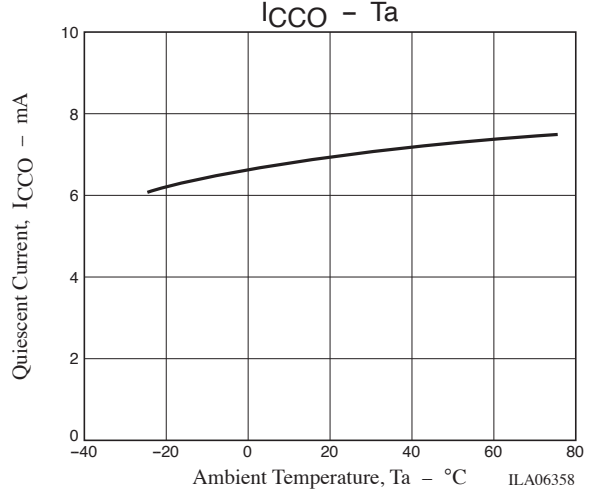
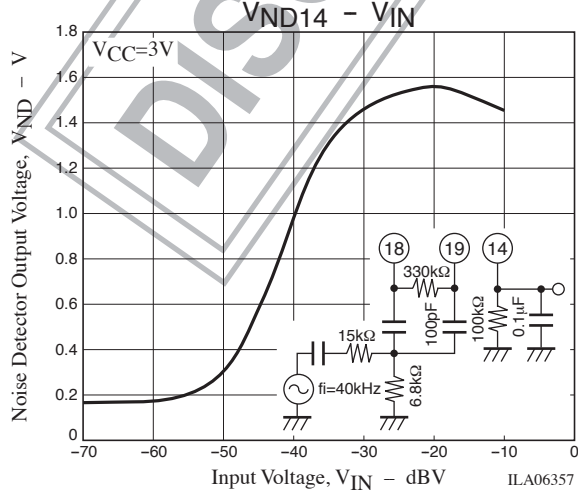
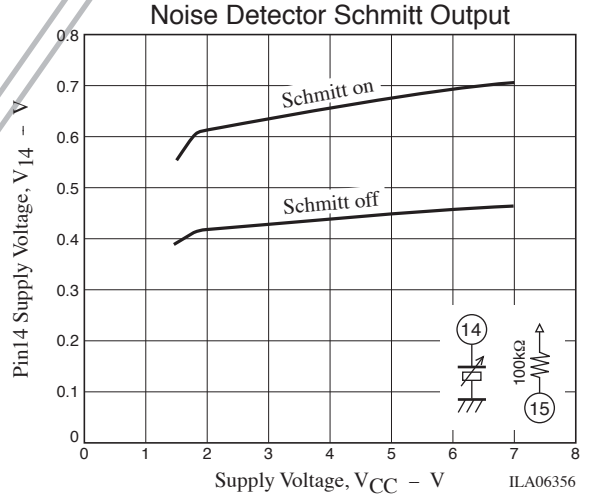
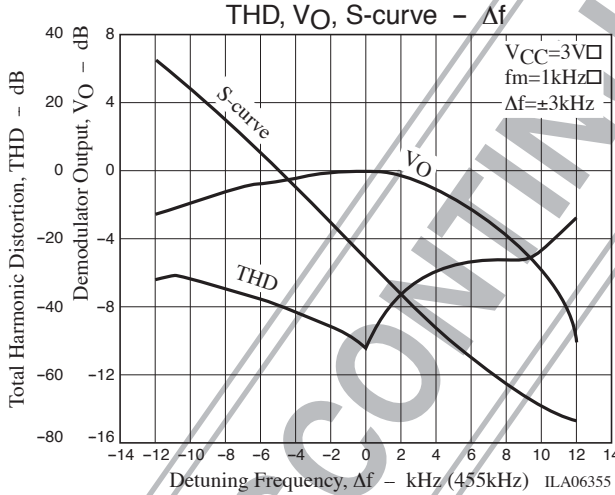
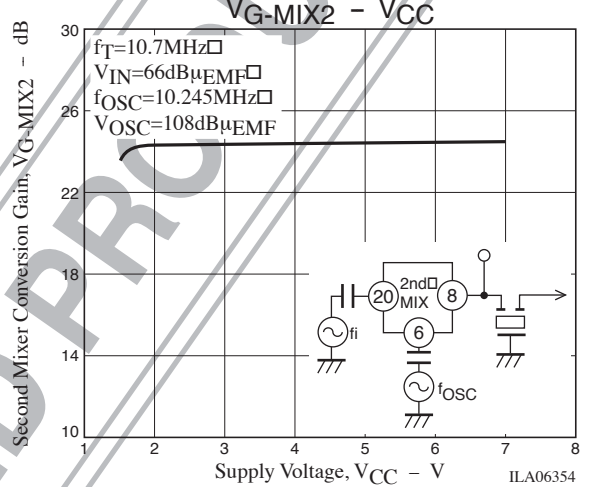
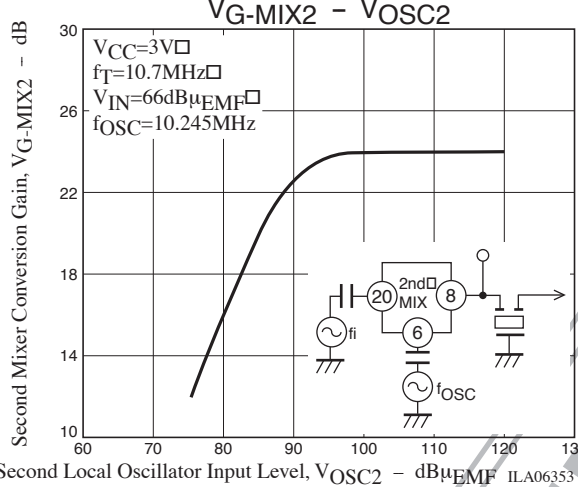
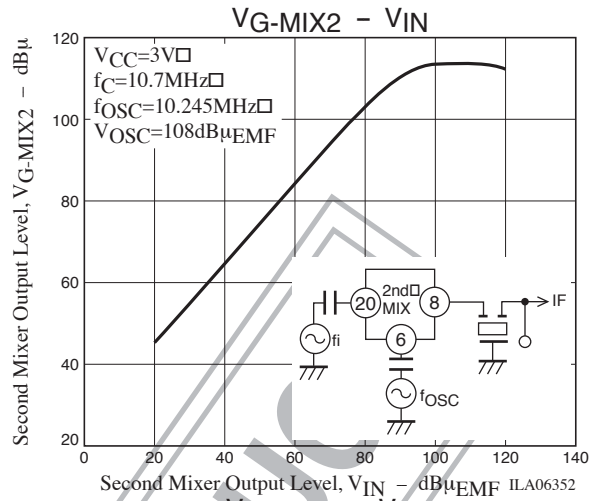
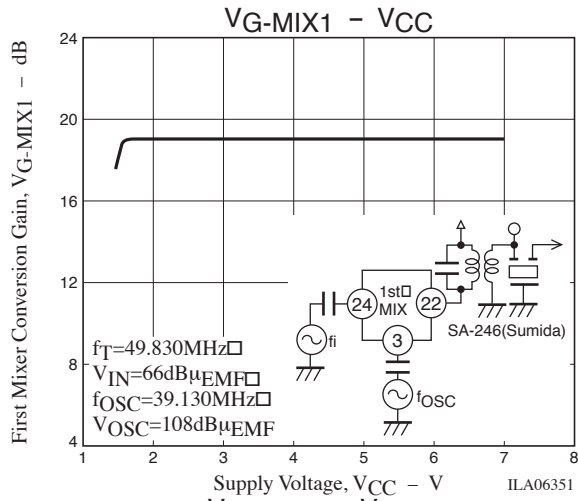

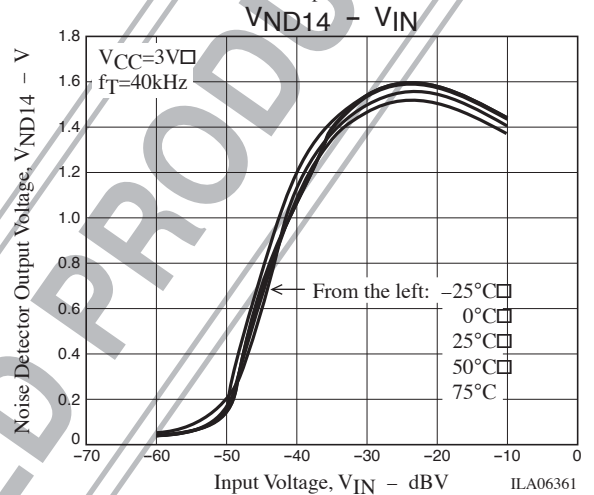
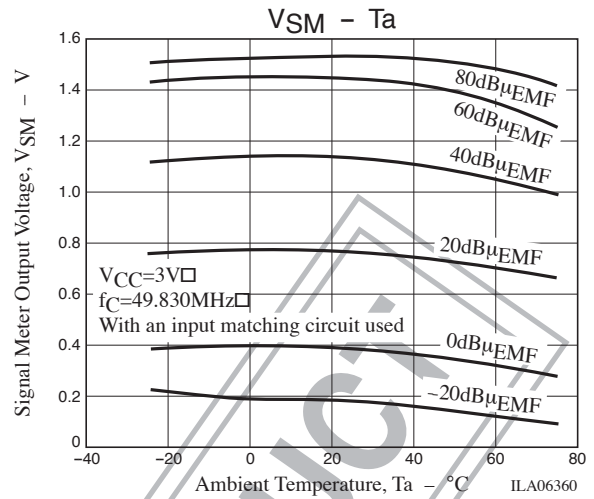
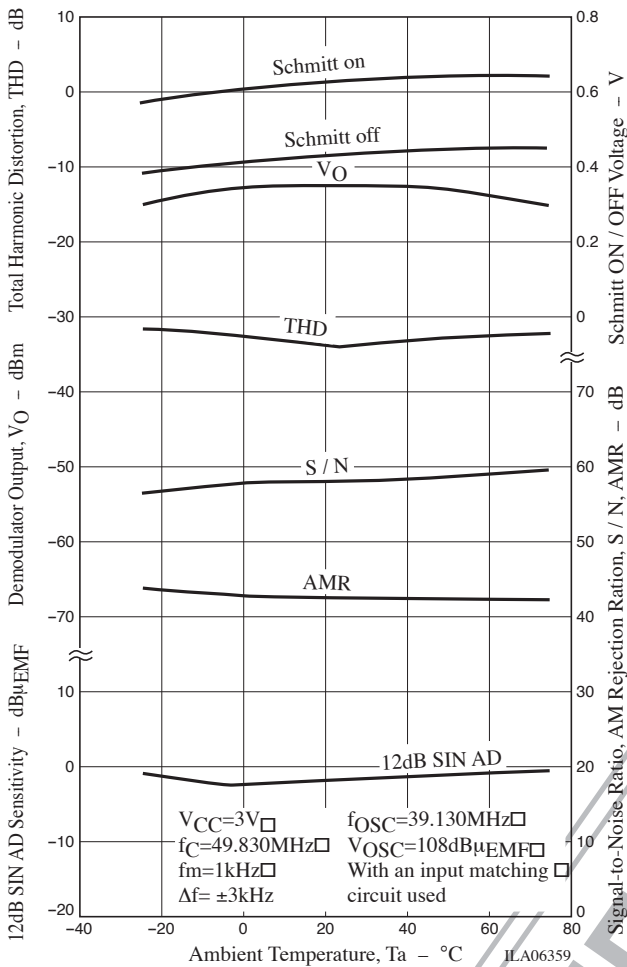

■ Specifications of any and all SANYO Semiconductor products described or contained herein stipulate the performance, characteristics, and functions of the described products in the independent state, and are not guarantees of the performance, characteristics, and functions of the described products as mounted in the customer's products or equipment. To verify symptoms and states that cannot be evaluated in an independent device, the customer should always evaluate and test devices mounted in the customer's products or equipment.

■ SANYO Semiconductor Co., Ltd. strives to supply high-quality high-reliability products. However, any and all semiconductor products fail with some probability. It is possible that these probabilistic failures could give rise to accidents or events that could endanger human lives, that could give rise to smoke or fire, or that could cause damage to other property. When designing equipment, adopt safety measures so that these kinds of accidents or events cannot occur. Such measures include but are not limited to protective circuits and error prevention circuits for safe design, redundant design, and structural design.

■ In the event that any or all SANYO Semiconductor products (including technical data, services) described or contained herein are controlled under any of applicable local export control laws and regulations, such products must not be exported without obtaining the export license from the authorities concerned in accordance with the above law.

■ No part of this publication may be reproduced or transmitted in any form or by any means, electronic or mechanical, including photocopying and recording, or any information storage or retrieval system, or otherwise, without the prior written permission of SANYO Semiconductor Co., Ltd.

■ Any and all information described or contained herein are subject to change without notice due to product/technology improvement, etc. When designing equipment, refer to the "Delivery Specification" for the SANYO Semiconductor product that you intend to use.

■ Information (including circuit diagrams and circuit parameters) herein is for example only; it is not guaranteed for volume production. SANYO Semiconductor believes information herein is accurate and reliable, but no guarantees are made or implied regarding its use or any infringements of intellectual property rights or other rights of third parties.

This catalog provides information as of January, 2006. Specifications and information herein are subject to change without notice.