

# UT54ACS244E

## Octal Buffers & Line Drivers

December 2014

www.aeroflex.com/Logic

Advanced Datasheet



### FEATURES

- Three-state outputs drive bus lines or buffer memory address registers
- 0.6µm CRH CMOS Process
  - Latchup immune
- High speed
- Low power consumption
- Wide power supply operating range of 3.0V to 5.5V
- Available QML Q or V processes
- 20-lead flatpack
- UT54ACS244E - SMD 5962-96570

### DESCRIPTION

The UT54ACS244E is non-inverting octal buffers and line drivers which improve the performance and density of three-state memory address drivers, clock drivers, and bus-oriented receivers and transmitters.

The device is characterized over full military temperature range of -55°C to +125°C.

### PINOUT

20-Lead Flatpack  
Top View

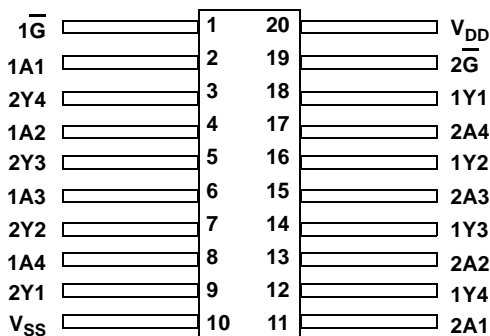

### FUNCTION TABLE

INPUTS		OUTPUT
$\overline{1G}, \overline{2G}$	A	Y
L	L	L
L	H	H
H	X	Z

### LOGIC SYMBOL

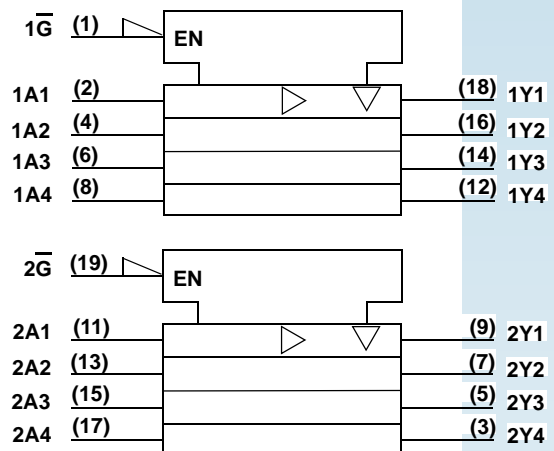

#### Note:

1. Logic symbol in accordance with ANSI/IEEE standard 91-1984 and IEC Publication 617-12.

### LOGIC DIAGRAM

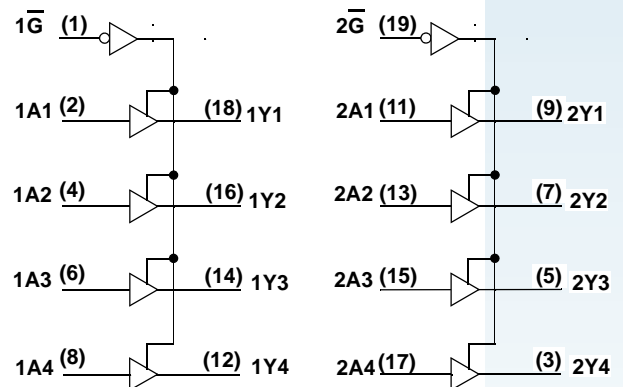

## OPERATIONAL ENVIRONMENT <sup>1</sup>

PARAMETER	LIMIT	UNITS
Total Dose	1.0E6	rads(Si)
SEU Threshold <sup>2</sup>	108	MeV-cm <sup>2</sup> /mg
SEL Threshold	120	MeV-cm <sup>2</sup> /mg
Neutron Fluence	1.0E14	n/cm <sup>2</sup>

**Notes:**

1. Logic will not latchup during radiation exposure within the limits defined in the table.
2. Device storage elements are immune to SEU affects.

## ABSOLUTE MAXIMUM RATINGS

SYMBOL	PARAMETER	LIMIT	UNITS
V <sub>DD</sub>	Supply voltage	-0.3 to 7.0	V
V <sub>I/O</sub>	Voltage any pin	-0.3 to V <sub>DD</sub> + 0.3	V
T <sub>STG</sub>	Storage Temperature range	-65 to +150	°C
T <sub>J</sub>	Maximum junction temperature	+175	°C
T <sub>LS</sub>	Lead temperature (soldering 5 seconds)	+300	°C
Θ <sub>JC</sub>	Thermal resistance junction to case	15	°C/W
I <sub>I</sub>	DC input current	±10	mA
P <sub>D</sub> <sup>2</sup>	Maximum package power dissipation permitted @ T <sub>c</sub> = +125°C	3.3	W

**Note:**

1. Stresses outside the listed absolute maximum ratings may cause permanent damage to the device. This is a stress rating only, functional operation of the device at these or any other conditions beyond limits indicated in the operational sections is not recommended. Exposure to absolute maximum rating conditions for extended periods may affect device reliability.
2. Per MIL-STD-883, method 1012.1, Section 3.4.1,  $P_D = (T_{j(max)} - T_{c(max)}) / \Theta_{jc}$

## RECOMMENDED OPERATING CONDITIONS

SYMBOL	PARAMETER	LIMIT	UNITS
V <sub>DD</sub>	Supply voltage	3.0 to 5.5	V
V <sub>IN</sub>	Input voltage any pin	0 to V <sub>DD</sub>	V
T <sub>C</sub>	Temperature range	-55 to +125	°C

## DC ELECTRICAL CHARACTERISTICS FOR THE UT54ACS244E<sup>7</sup>

( $V_{DD} = 3.3V$  to  $5.5V$ ;  $V_{SS} = 0V$ <sup>6</sup>,  $-55^{\circ}C < T_C < +125^{\circ}C$ );

SYMBOL	DESCRIPTION	CONDITION	MIN	MAX	UNIT
$V_{IL}$	Low-level input voltage <sup>1</sup>	$V_{DD} = 3.0V$ to $5.5V$		$0.3V_{DD}$	V
$V_{IH}$	High-level input voltage <sup>1</sup>	$V_{DD} = 3.0V$ to $5.5V$	$0.7V_{DD}$		V
$I_{IN}$	Input leakage current	$V_{IN} = V_{DD}$ or $V_{SS}$	-1	1	$\mu A$
$V_{OL}$	Low-level output voltage <sup>3</sup>	$I_{OL} = 100\mu A$ $V_{DD} = 3.0V$ to $5.5V$		0.25	V
$V_{OH}$	High-level output voltage <sup>3</sup>	$I_{OH} = -100\mu A$ $V_{DD} = 3.0V$ to $5.5V$	$V_{DD} - .025$		V
$I_{OS1}$	Short-circuit output current <sup>2,4</sup>	$V_O = V_{DD}$ and $V_{SS}$ $V_{DD}$ from $4.5V$ to $5.5V$	-300	+300	mA
$I_{OS2}$	Short-circuit output current <sup>2,4</sup>	$V_O = V_{DD}$ and $V_{SS}$ $V_{DD}$ from $3.0V$ to $3.6V$	-150	+150	mA
$I_{OL1}$	Low level output current <sup>10</sup>	$V_{IN} = V_{DD}$ or $V_{SS}$ $V_{OL} = 0.4V$ $V_{DD}$ from $4.5V$ to $5.5V$	+12		mA
$I_{OL2}$	Low level output current <sup>10</sup>	$V_{IN} = V_{DD}$ or $V_{SS}$ $V_{OL} = 0.4V$ $V_{DD}$ from $3.0V$ to $3.6V$	+8		mA
$I_{OH1}$	High level output current <sup>10</sup>	$V_{IN} = V_{DD}$ or $V_{SS}$ $V_{OH} = V_{DD} - 0.4V$ $V_{DD}$ from $4.5V$ to $5.5V$	-12		mA
$I_{OH2}$	High level output current <sup>10</sup>	$V_{IN} = V_{DD}$ or $V_{SS}$ $V_{OH} = V_{DD} - 0.4V$ $V_{DD}$ from $3.0V$ to $3.6V$	-8		mA
$I_{OZ}$	Three-state output leakage current	$V_O = V_{DD}$ and $V_{SS}$	-30	30	$\mu A$
$P_{total1}$	Power dissipation <sup>2, 8, 9</sup>	$C_L = 50pF$ $V_{DD}$ from $4.5V$ to $5.5V$		1.5	mW/ MHz
$P_{total2}$	Power dissipation <sup>2, 8, 9</sup>	$C_L = 50pF$ $V_{DD}$ from $3.0V$ to $3.6V$		0.75	mW/ MHz

$I_{DDQ}$	Quiescent Supply Current	$V_{IN} = V_{DD}$ or $V_{SS}$ $V_{DD}$ from 3.6V to 5.5V		25	$\mu A$
$C_{IN}$	Input capacitance <sup>5</sup>	$f = 1MHz$ $V_{DD} = 0V$		15	pF
$C_{OUT}$	Output capacitance <sup>5</sup>	$f = 1MHz$ $V_{DD} = 0V$		15	pF

**Notes:**

- Functional tests are conducted in accordance with MIL-STD-883 with the following input test conditions:  $V_{IH} = V_{IH(min)} + 20\%$ ,  $- 0\%$ ;  $V_{IL} = V_{IL(max)} + 0\%$ ,  $- 50\%$ , as specified herein, for TTL, CMOS, or Schmitt compatible inputs. Devices may be tested using any input voltage within the above specified range, but are guaranteed to  $V_{IH(min)}$  and  $V_{IL(max)}$ .
- Supplied as a design limit but not guaranteed or tested.
- Per MIL-PRF-38535, for current density  $\leq 5.0E5$  amps/cm<sup>2</sup>, the maximum product of load capacitance (per output buffer) times frequency should not exceed 3,765pF/MHz.
- Not more than one output may be shorted at a time for maximum duration of one second.
- Capacitance measured for initial qualification and when design changes may affect the value. Capacitance is measured between the designated terminal and  $V_{SS}$  at frequency of 1MHz and a signal amplitude of 50mV rms maximum.
- Maximum allowable relative shift equals 50mV.
- For devices procured with a total ionizing dose tolerance guarantee, the post-irradiation performance is guaranteed at 25°C per MIL-STD-883 method 1019 condition A up to the maximum TID level procured.
- Power does not include power contribution of any TTL output sink current.
- Power dissipation specified per switching output.
- Guaranteed by characterization, but not tested.

## AC ELECTRICAL CHARACTERISTICS FOR THE UT54ACS244E<sup>2</sup>

( $V_{DD} = 3.0V$  to  $5.5V$ ;  $V_{SS} = 0V$ <sup>1</sup>,  $-55^{\circ}C < T_C < +125^{\circ}C$ );

SYMBOL	PARAMETER	Condition	$V_{DD}$	MINIMUM	MAXIMUM	UNIT
$t_{PLH}$	Input to $Y_n$	CL = 50pF	4.5V to 5.5V	1	6.5	ns
			3.0V to 3.6V	1	9.5	
$t_{PHL}$	Input to $Y_n$	CL = 50pF	4.5V to 5.5V	1	7.5	ns
			3.0V to 3.6V	1	10.5	
$t_{PZL}$	$\overline{G}$ low to $Y_n$ active	CL = 50pF	4.5V to 5.5V	1	6	ns
			3.0V to 3.6V	1	8	
$t_{PZH}$	$\overline{G}$ low to $Y_n$ active	CL = 50pF	4.5V to 5.5V	1	7	ns
			3.0V to 3.6V	1	9.5	
$t_{PLZ}$	$\overline{G}$ high to $Y_n$ three-state	CL = 50pF	4.5V to 5.5V	1	6	ns
			3.0V to 3.6V	1	7.5	
$t_{PHZ}$	$\overline{G}$ high to $Y_n$ three-state	CL = 50pF	4.5V to 5.5V	1	9.5	ns
			3.0V to 3.6V	1	11	

**Notes:**

1. Maximum allowable relative shift equals 50mV.
2. For devices procured with a total ionizing dose tolerance guarantee, the post-irradiation performance is guaranteed at 25°C per MIL-STD-883 method 1019 condition A up to the maximum TID level procured.

# Packaging

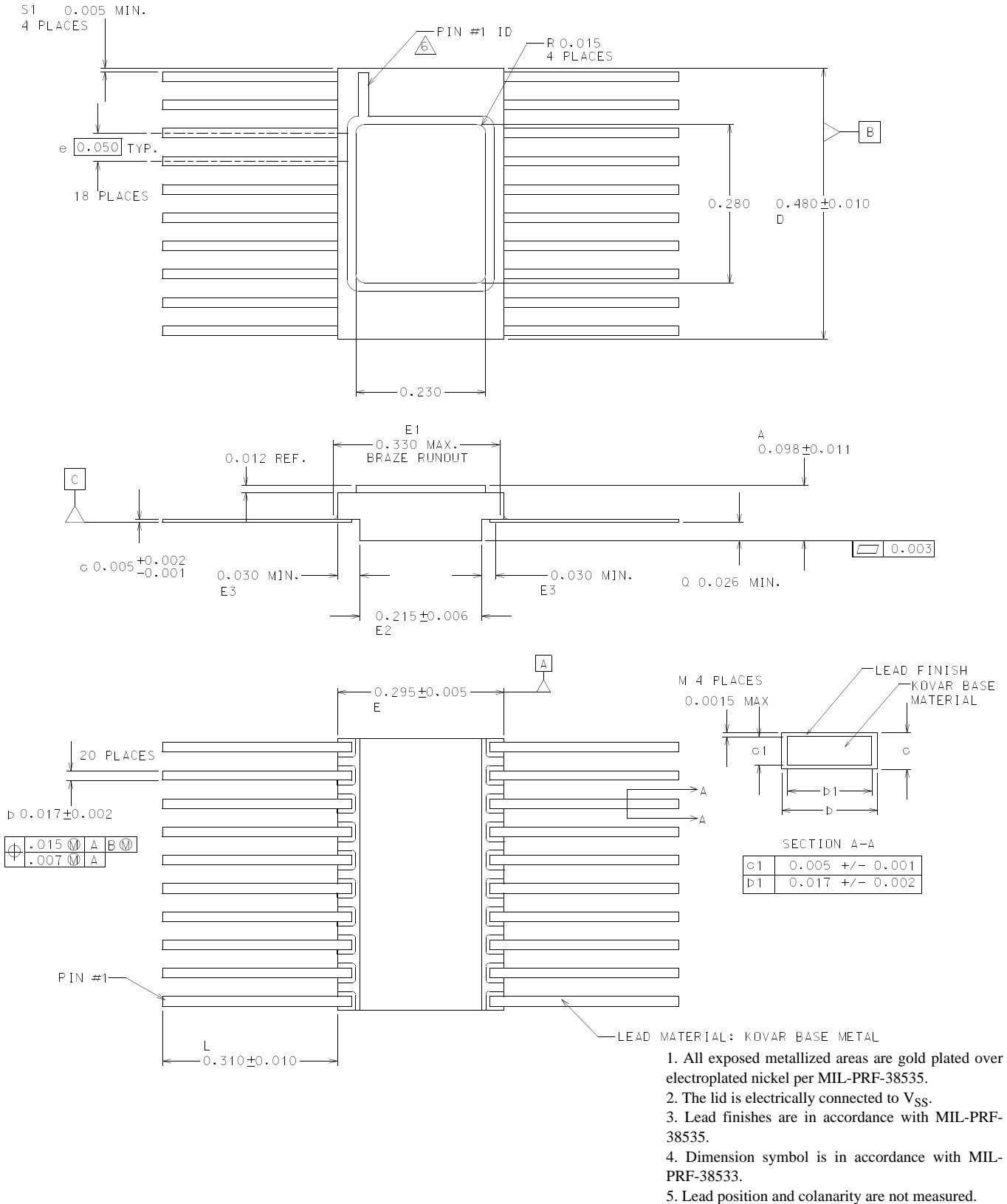

**Figure 1. 20-lead Flatpack**

**Ordering Information: UT54ACS244E / UT54ACTS244E: SMD**

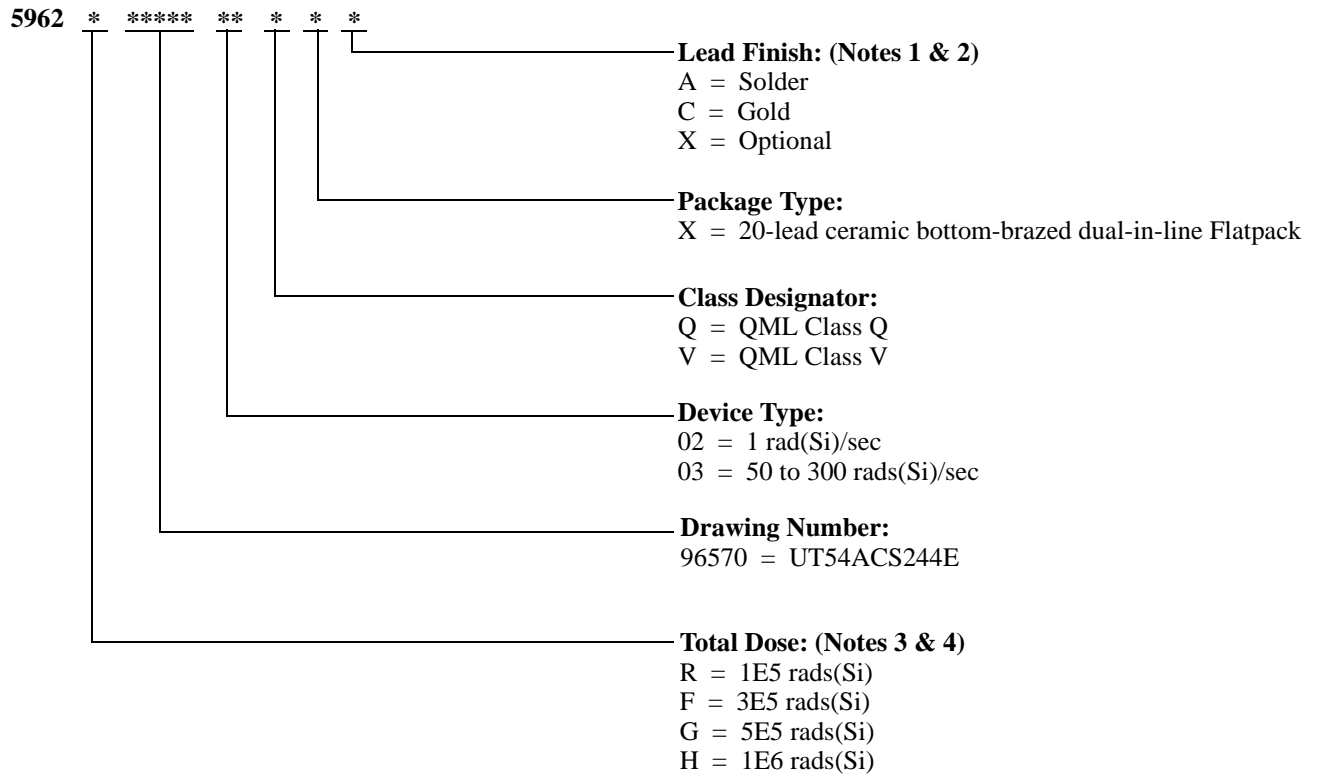

**Notes:**

1. Lead finish (A,C, or X) must be specified.
2. If an "X" is specified when ordering, part marking will match the lead finish and will be either "A" (solder) or "C" (gold).
3. Total dose radiation must be specified when ordering. QML Q and QML V not available without radiation hardening. For prototype inquiries, contact factory.
4. Device type 02 is only offered with a TID tolerance guarantee of 3E5 rads(Si) or 1E6 rads(Si) and is tested in accordance with MIL-STD-883 Test Method 1019 Condition A and section 3.11.2. Device type 03 is only offered with a TID tolerance guarantee of 1E5 rads(Si), 3E5 rads(Si), and 5E5 rads(Si), and is tested in accordance with MIL-STD-883 Test Method 1019 Condition A.

## ***Aeroflex Colorado Springs - Datasheet Definition***

**Advanced Datasheet - Product In Development**

**Preliminary Datasheet - Shipping Prototype**

**Datasheet - Shipping QML & Reduced HiRel**

**This product is controlled for export under the U.S. Department of Commerce (DoC). A license may be required prior to the export of this product from the United States.**

*www.aeroflex.com      info-ams@aeroflex.com*



Aeroflex Colorado Springs (Aeroflex) reserves the right to make changes to any products and services herein at any time without notice. Consult Aeroflex or an authorized sales representative to verify that the information in this data sheet is current before using this product. Aeroflex does not assume any responsibility or liability arising out of the application or use of any product or service described herein, except as expressly agreed to in writing by Aeroflex; nor does the purchase, lease, or use of a product or service from Aeroflex convey a license under any patent rights, copyrights, trademark rights, or any other of the intellectual rights of Aeroflex or of third parties.



Our passion for performance is defined by three attributes represented by these three icons: solution-minded, performance-driven and customer-focused

**Datasheet Revision History**

<b>Revision Date</b>	<b>Description of Change</b>
<b>December 2014 Version 1.0.0</b>	<b>Initial Release of Data Sheet</b>