

M56781FP

2-CHANNEL ACTUATOR MOTOR DRIVER

DESCRIPTION

The M56781FP is a semiconductor IC developed as the motor driver used DVD, DVD-ROM, CD-ROM and CD Player. This device include 2 channel BTL drivers and can drive 2 actuators with one IC at the same time. Also, the mute circuit, thermal protection circuit and VREF voltage monitor circuit functions are included.

FEATURES

- Low output saturation voltage (typ. 1.35V at 0.5A).
- Wide operating supply voltage range (4.5 – 15V).
- High current drive capability (maximum 0.9A).
- Low crossover distortion.
- High frequency capability.

APPLICATION

DVD, DVD-ROM, CD-ROM, CD-PLAYER

PIN CONFIGURATION (TOP VIEW)

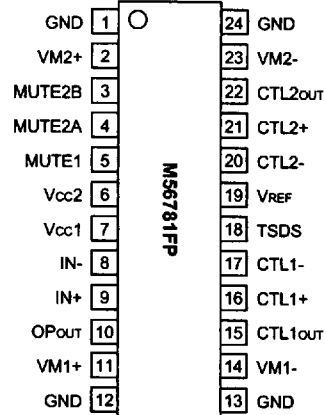

Outline 24P2Q-A

BLOCK DIAGRAM

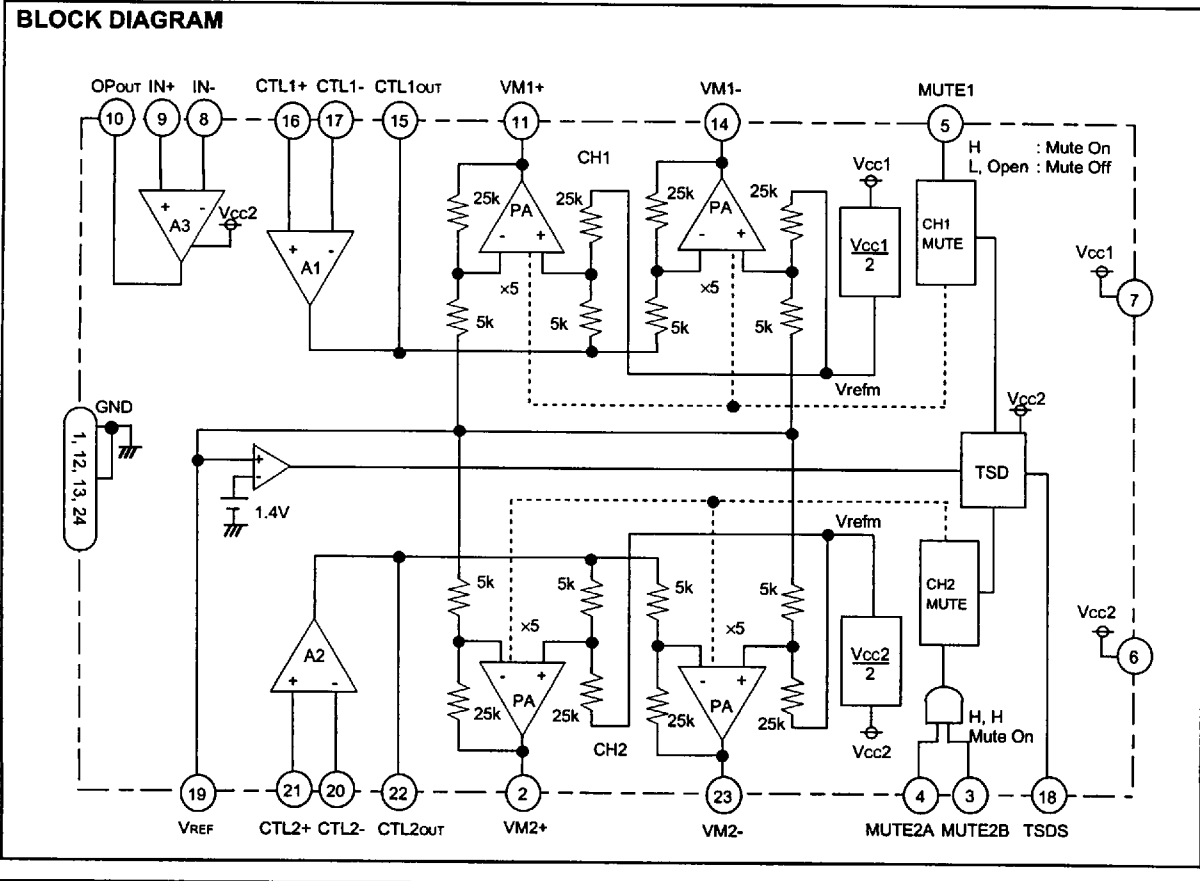

PIN DESCRIPTIONS

| Pin No. | Symbol | Function | Pin No. | Symbol | Function |
|---------|--------|------------------------------|---------|---------|-----------------------------|
| ① | GND | GND | ⑬ | GND | GND |
| ② | VM2+ | CH2 Amp. non-inverted output | ⑭ | VM1- | CH1 Amp. inverted output |
| ③ | MUTE2B | CH2 mute B | ⑮ | CTL1out | CH1 input Amp. output |
| ④ | MUTE2A | CH2 mute A | ⑯ | CTL1+ | CH1 Amp. non-inverted input |
| ⑤ | MUTE1 | CH1 mute | ⑰ | CTL1- | CH1 Amp. inverted input |
| ⑥ | Vcc2 | Power supply 2 | ⑱ | TSDS | Thermal monitor |
| ⑦ | Vcc1 | Power supply 1 | ⑲ | VREF | Reference voltage input |
| ⑧ | IN- | Op-Amp. inverted input | ⑳ | CTL2- | CH2 Amp. inverted input |
| ⑨ | IN+ | Op-Amp. non-inverted input | ㉑ | CTL2+ | CH2 Amp. non-inverted input |
| ⑩ | OPout | Op-Amp. output | ㉒ | CTL2out | CH2 input Amp. output |
| ⑪ | VM1+ | CH1 Amp. non-inverted output | ㉓ | VM2- | CH2 Amp. inverted output |
| ⑫ | GND | GND | ㉔ | GND | GND |

ABSOLUTE MAXIMUM RATING (Ta = 25°C)

| Symbol | Parameter | Conditions | Rating | Units |
|--------|---|-------------------------------|------------|-------|
| Vcc | Power supply | ⑥, ⑦ pins | 15 | V |
| Io | Output Current | Vcc = Vbs = 12V | 900 | mA |
| Vin | Maximum input voltage of each terminals | ③, ④, ⑤, ⑧, ⑨, ⑱, ⑲, ⑳, ㉑ pin | 0 - Vcc | V |
| Pd | Power dissipation | With infinite heatsink | 2.97 | W |
| Kθ | Thermal derating | With infinite heatsink | 42.1 | °C/W |
| Tj | Junction temperature | | 150 | °C |
| Topr | Operating temperature | | -20 - +75 | °C |
| Tstg | Storage temperature | | -40 - +150 | °C |

RECOMMENDED OPERATING CONDITIONS

| Symbol | Parameter | Limits | | | Units |
|---------|--------------|--------|------|------|-------|
| | | Min. | Typ. | Max. | |
| Vcc1, 2 | Power supply | | 12 | | V |

ELECTRICAL CHARACTERISTICS (Ta = 25°C, Vcc1 = Vcc2 = Vbs2 = 12V, Load = 0 unless otherwise noted.)

| Symbol | Parameter | Measurement condition | Limits | | | Units |
|----------|---|---|--------|------|------|-------|
| | | | Min. | Typ. | Max. | |
| Icc1 | Power supply current - 1 (at Enable condition) | ⑥, ⑦ pins current at VREF = 0. | — | 1.0 | 2.0 | mA |
| Icc2 | Power supply current - 2 (at Mute condition) | ⑥, ⑦ pins current at VREF = VCTL = 2.5V, MUTE = 5V. | — | 4.5 | 7.0 | mA |
| Icc3 | Power supply current - 3 | ⑥, ⑦ pins current at VREF = VCTL = 2.5V, MUTE = 0V. | — | 23 | 37 | mA |
| VSAT | Output saturation voltage | Top and Bottom power Transistors saturation voltage (at Io = 0.5A). | — | 1.35 | 1.9 | V |
| VOFS1 | Output Amp. Offset voltage 1 | VREF = VCTL = 2.5V, Vcc = VBS = 5V (CTL Amp. = buffer.) | -27 | — | +27 | mV |
| VOFS2 | Output Amp. Offset voltage 2 | VREF = VCTL = 2.5V, Vcc = VBS = 12V (CTL Amp. = buffer.) | -78 | — | +78 | mV |
| GAIN | Voltage Gain between input and output | $\frac{VM(+)-VM(-)}{VCTL-VREF}$ (CTL Amp. = buffer.) | 19.1 | 20 | 20.8 | dB |
| VMUTEON | Mute ON voltage | CH2 is Mute-ON mode when MUTE2A = H and MUTE2B = H condition. | 2.0 | — | — | V |
| VMUTEOFF | Mute OFF voltage | | — | — | 0.8 | V |
| IMUTE | Mute input current | MUTE1 = MUTE2A = MUTE2B = 5V | — | 190 | 250 | μA |

M56781FP

2-CHANNEL ACTUATOR MOTOR DRIVER

ELECTRICAL CHARACTERISTICS (Ta = 25°C, Vcc1 = Vcc2 = Vbs1 = Vbs2 = 12V, Load = 0)

| Symbol | Parameter | Test conditions | Limits | | | Units |
|--------|-------------------------------|---|--------|-------|---------|-------|
| | | | Min. | Typ. | Max. | |
| VCTLIN | CTL Amp. Input voltage range | A1 and A2 Amps. | 1.5 | — | Vcc-1.2 | V |
| VCTLIN | CTL Amp. Output voltage range | A1 and A2 Amps. Load = 0 | 1.0 | — | Vcc-1.0 | V |
| VA3IN | A3 Amp. Input voltage range | | 0 | — | Vcc-1.9 | V |
| VA3OUT | A3 Amp. Output voltage range | Load = 0 | 1.0 | — | Vcc-1.0 | V |
| VA3OFS | A3 Amp. Offset voltage | Load = 0 | -5 | — | +5 | mV |
| VREFS | VREF monitor voltage | When VREF voltage is under this values, M56781FP makes the Bias shut off. | — | 1.4 | 1.8 | V |
| VREF1 | VREF input current | VREF = 2.5V 1.25V ≤ VCTL ≤ 3.75V | -1 | -0.37 | 0.1 | mA |

CH1 AND CH2 INPUT AND OUTPUT CHARACTERISTICS

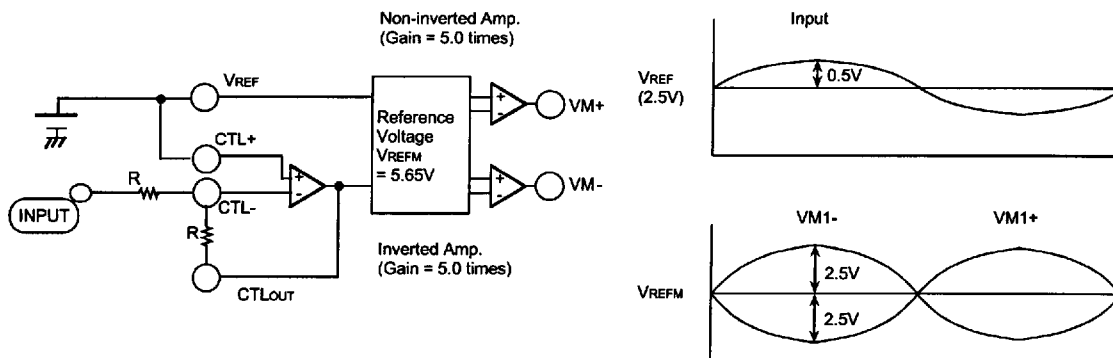

THERMAL DRATING CURVE

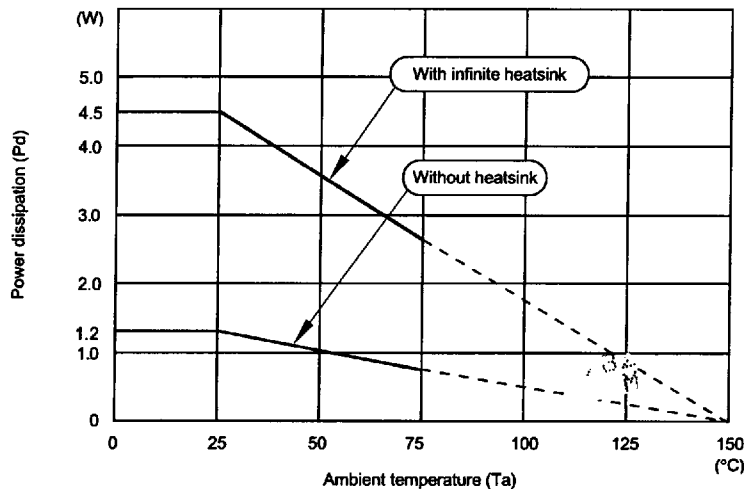

TYPICAL CHARACTERISTICS

Output Saturation Voltage - Load Current Characteristics.

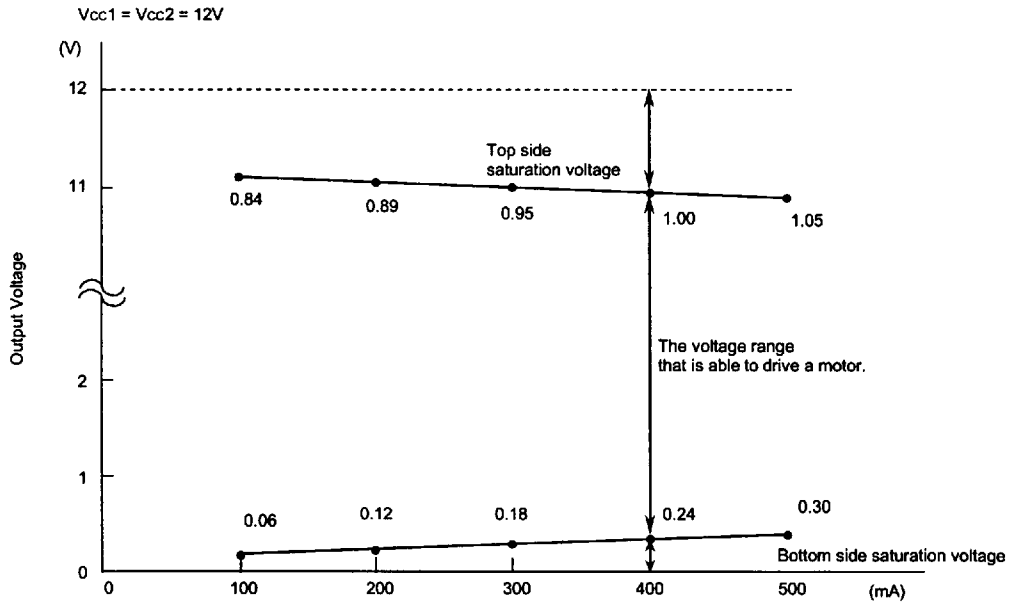

FREQUENCY CHARACTERISTICS

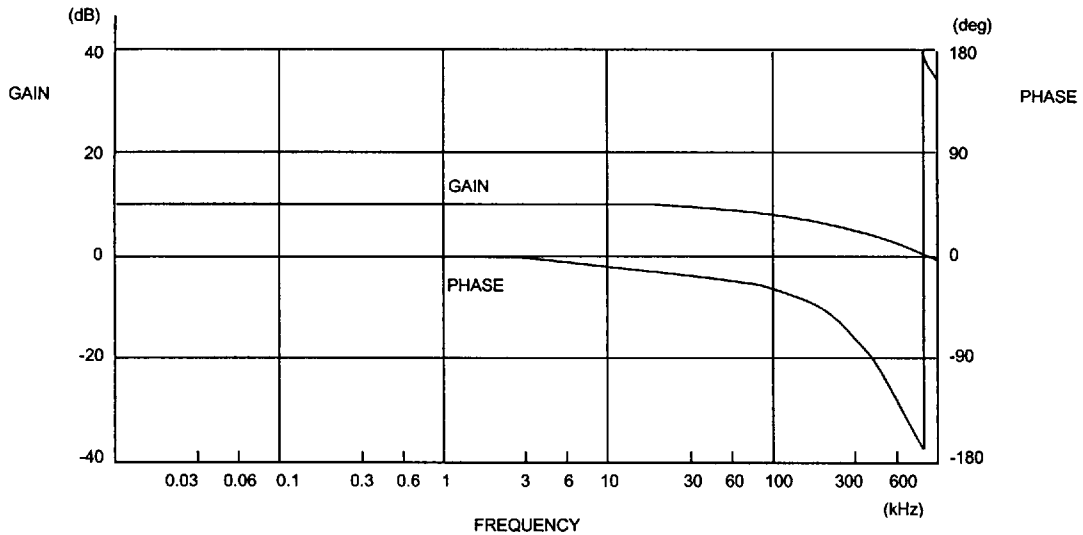

APPLICATION CIRCUIT This show the 4 actuators drive circuit using two M56781FP.

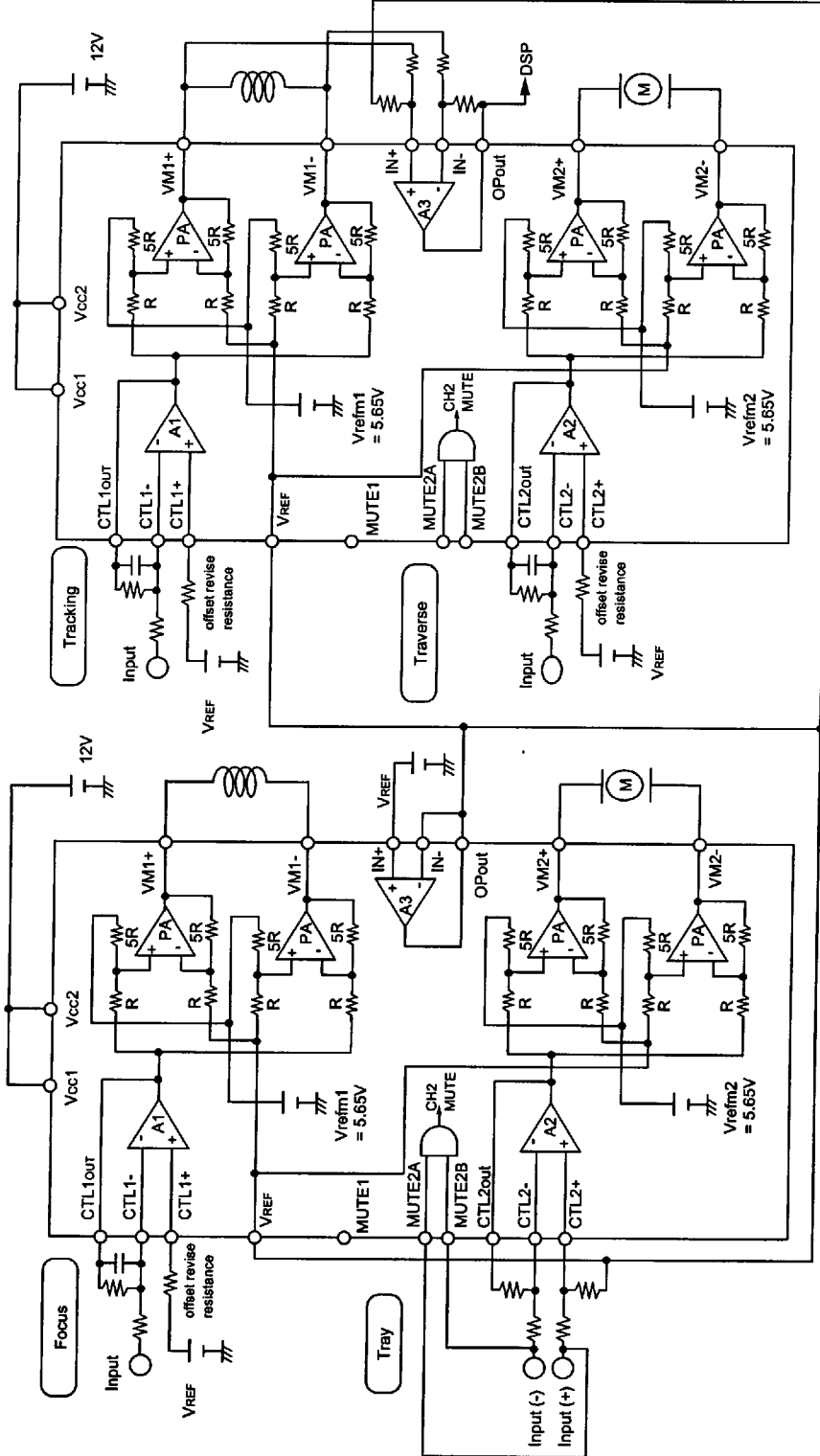

If MUTE2A and MUTE2B are connected to Input(+) and Input(-), this device can be shut off the output when Input(-) and Input(+) are High condition.

| | | | |
|-------|-----------|---------|----------|
| Tray | Input (+) | L | H |
| | Input (-) | L | H |
| Focus | Stop (SB) | Reverse | Forward |
| | Input (+) | Reverse | Shut off |