

## HXW0767-610011

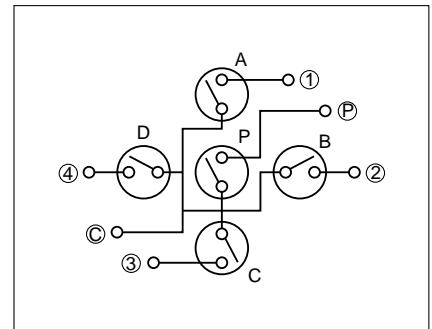

Circuit Diagram

Ratings		50 mA 20 V DC max.
		10 $\mu$ A 1 V DC min.
Contact Resistance		100 m $\Omega$ max.
Insulation Resistance		100 M $\Omega$ min. at 100 V DC
Dielectric Strength		100 V AC / 1 minute
Operating Force	X/Y Axis 4-Direction	0.9 N to 4 N
	Push Direction	2.3 N to 0.6 N
Operating Life		500,000 cycles

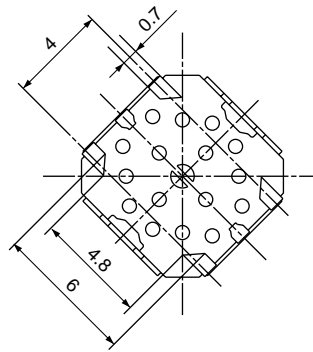
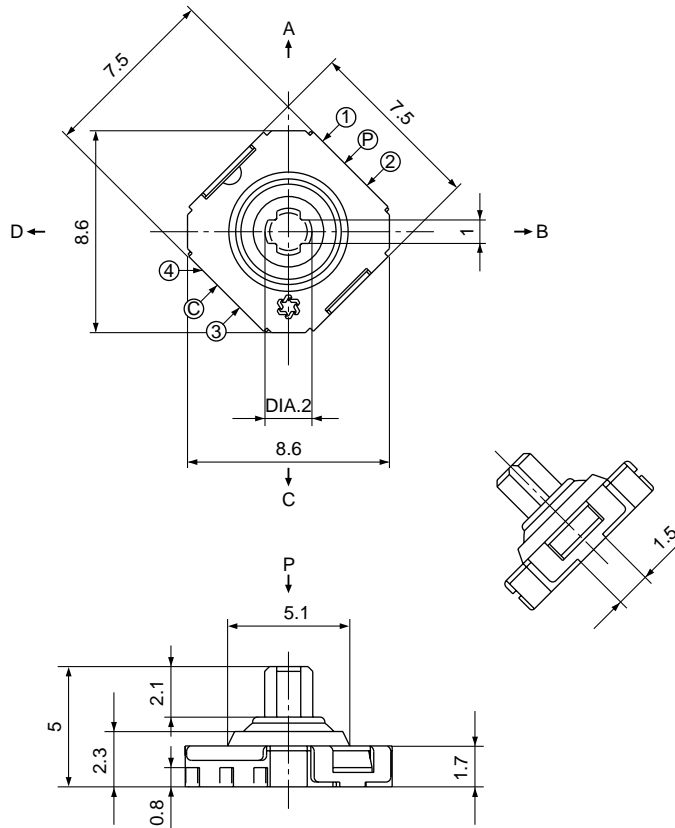
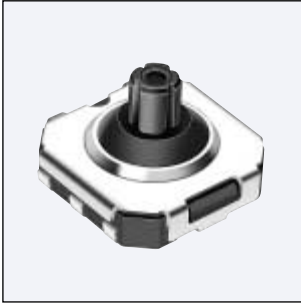
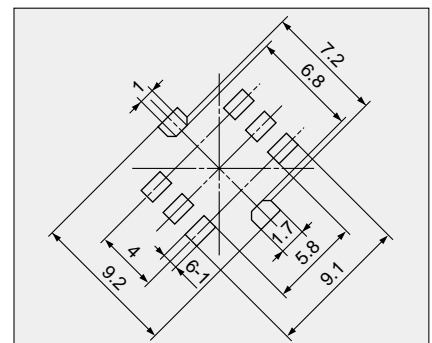

PCB Layout