

AN7235K/S

RF + FM-IF + AM Tuner + MPX 1 Chip IC
for Radio/Radio Cassette Tape Recorders

■ Description

The AN7235K/S are monolithic integrated circuits with FM FE, AM/FM IF, AM FE, FM MPX, AM Det and AGC built-in. It is suitable for radio and radio/cassette recorder at 3V operation. Together with any power IC, a 2-chip radio system can be obtained.

■ Features

- 1-chip FM Tuner, AM Tuner & MPX
- Good Intermodulation characteristics
- Good AM Rejection ratio
- High sensitivity
- Few external components
- Wide operating voltage (1.8V~7.0V)
- Internal AM/FM switch

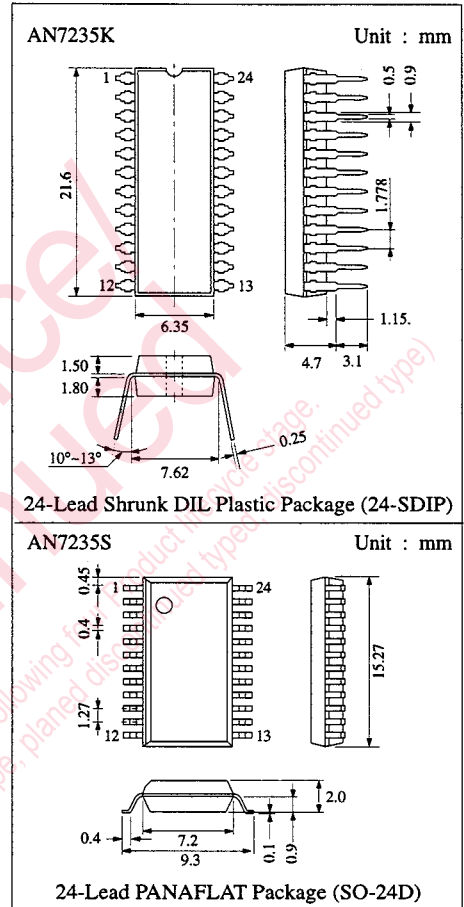

■ Block Diagram

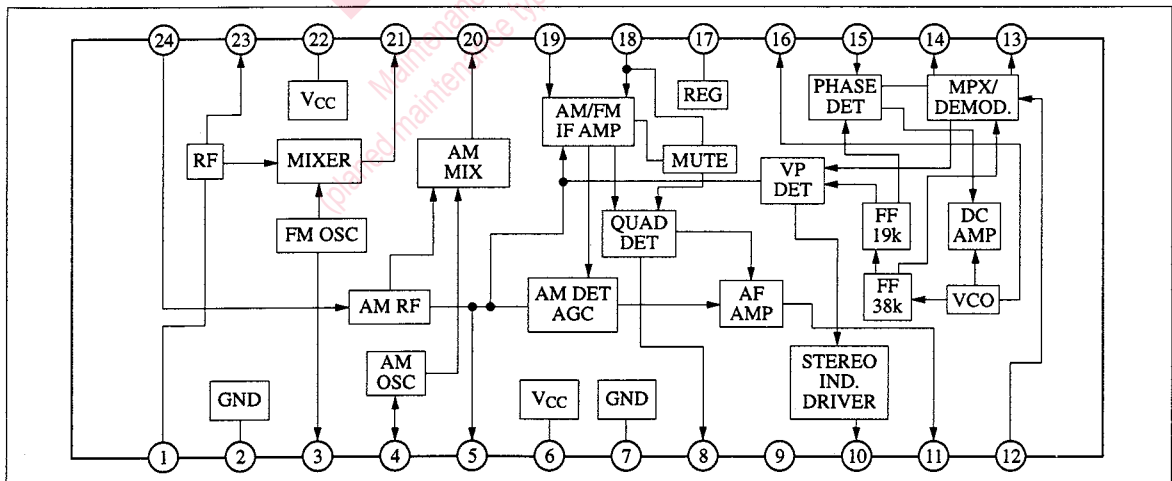

■ Absolute Maximum Ratings (Ta=25°C)

Item	Symbol	Rating	Unit
Supply Voltage	V _{CC}	7	V
Supply Current	I _{CC}	25	mA
Power Dissipation	P _D	175	mW
Operating Ambient Temperature	Topr	-20 ~ +75	°C
Storage Temperature	Tstg	-55 ~ +150	°C

Operating Supply Voltage Range: V_{CC} = 1.8V ~ 7.0V

■ Electrical Characteristics (V_{CC}=3V, Ta=25°C)

Item	Symbol	Condition	min.	typ.	max.	Unit
Quiescent Current (FM)	I _{lot}	No Input	10	15	22	mA
Quiescent Current (AM)	I _{lot}	No input	6	11	23	mA

FM FE

IF Output	V _{IF}	V _{in} = 55dBμ, f _{in} = 106MHz	81	85	89	dBμ
Oscillator Output	V _{OSC}	f _{OSC} = 116.7MHz	72			mV

FM

Detector Output Voltage	V _{O(FM)}	V _{in} = 80dBμ	42	56	80	mV
Limiting Sensitivity	V _{in(lim)}	V _{out} = -3dB	27	30	34	dBμ
Signal to Noise Ratio	S/N	V _{in} = 80dBμ	50			dB
Total Harmonic Distortion	THD	V _{in} = 80dBμ		0.5	1.5	%
AM Rejection Ratio	AMR	V _{in} = 80dBμ	25	32	40	dB

AM

AM Detector Out	V _{O(AM)}	V _{in} = 60dBμ	35	50	75	mV
Maximum Sensitivity	S _{max}	V _{out} = 10mV	10	17	26	dBμ
Signal to Noise Ratio	S/N	V _{in} = 80dBμ	40			dB
Total Harmonic Distortion	THD	V _{in} = 80dBμ		1.0	3.0	%
Oscillator Level	V _{OSC}	f _{OSC} = 1.455MHz	70			dBμ

MPX

Separation	Sep	V _{in} = 80dBμ, Stereo, 10% pilot	30	40		dB
Total Harmonic Distortion (Mono)	THD _(Mono)	V _{in} = 80dBμ, Mono		0.5	1.5	%
Total Harmonic Distortion (Stereo)	THD _(Stereo)	V _{in} = 80dBμ, Stereo, 10% pilot		0.5	1.5	%
Carrier Leak	CL	V _p = 10%	30			dB
Pilot 'ON' Level	V _{p(ON)}	V _{in} = 80dBμ, Stereo, V _p = 10%		5.5	8	%
Pilot 'OFF' Level	V _{p(OFF)}	V _{in} = 80dBμ, Stereo, V _p = 10%	1.1	4		mV
Capture Range	CR	Pilot 10%	±1.8	±3		%
Channel Balance	CB	V _{in} = 80dBμ, Mono	-1.2	0	1.2	dB

NB. FM: Unless specified, f_c = 10.7MHz, f = 1kHz, 30% Mod.

AM: Unless specified, f_c = 1MHz, f = 1kHz, 30% Mod.

■ Pin

Pin No	Pin Name	Pin No	Pin Name
1	FM RF In	13	R Ch Output
2	FM FE Gnd	14	L Ch Output
3	FM OSC	15	Phase Det
4	AM OSC	16	VCO
5	AGC/Pilot Det	17	IF Regulator
6	Vcc	18	AM IF Input / Mute Switch
7	GND	19	FM IF In
8	FM Detector	20	AM Mix Out
9	N.C.	21	FM Mix Out
10	Stereo Indicator	22	FM FE Vcc
11	Det Out	23	FM FE
12	MPX In	24	AM RF In

Test Circuit

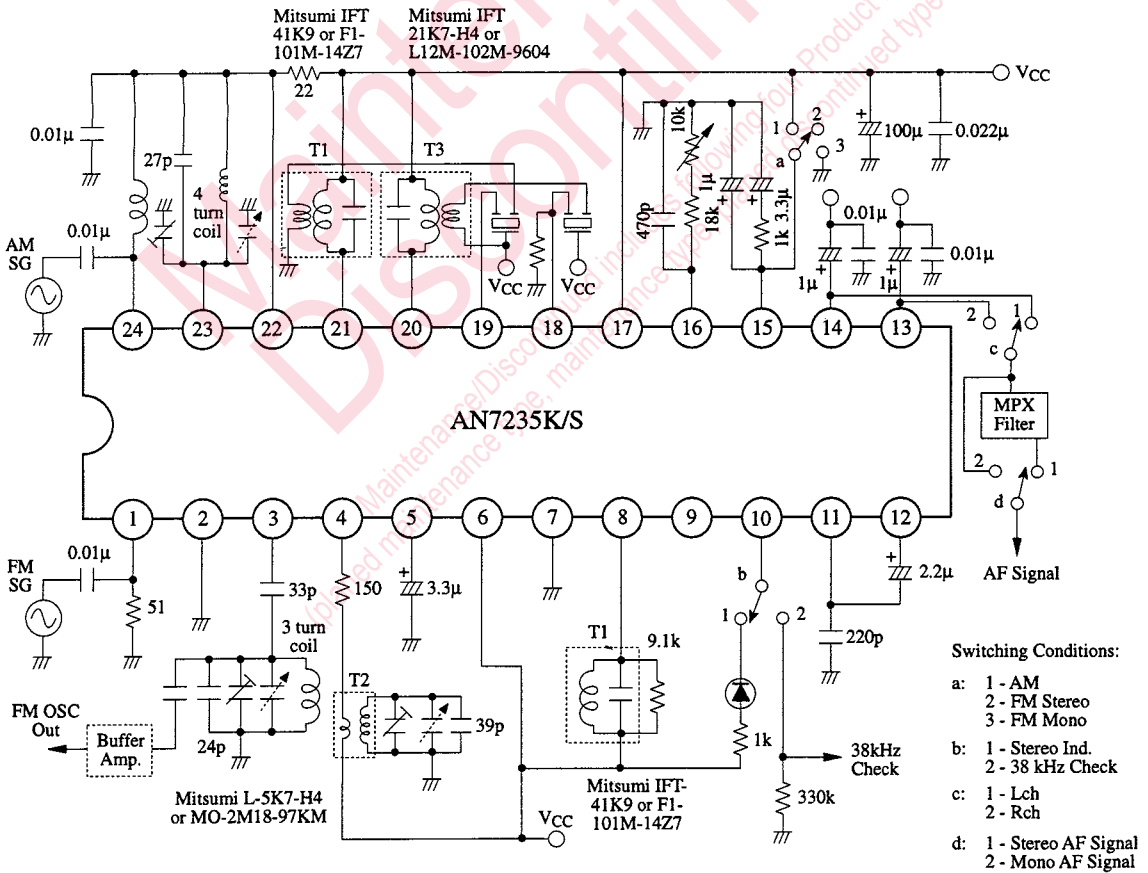

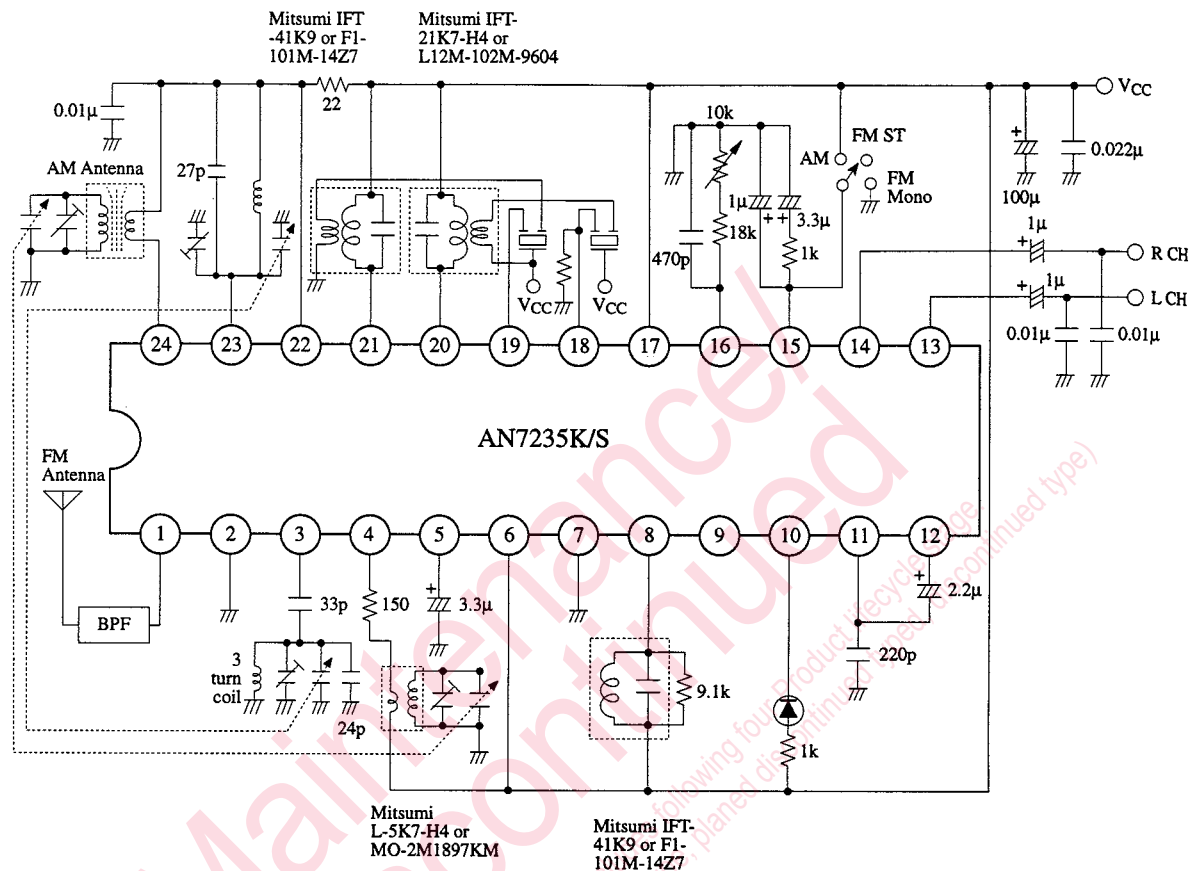

■ Application Circuit



■ Coil Specifications

Symbol	Use, Freq.	Type No.	Maker	Connection Diagram	Number of Turns	Tuning Cap.	Unloaded Q
T1	FM Quad Coil 10.7MHz	IFT-41K9	MITSUMI		①...② 7T ②...③ 4T ④...⑥ 2T	100pF	90±20%
T2	AM MW Osc. Coil	L-5K7-H4	MITSUMI		①...③ 87T ④...⑥ 6T	-	100±20%
T3	AM MIX Output 455kHz	IFT-21K7 H-4	MITSUMI		①...② 10T ②...③ 43T ④...⑥ 14T	1500pF	130±20%

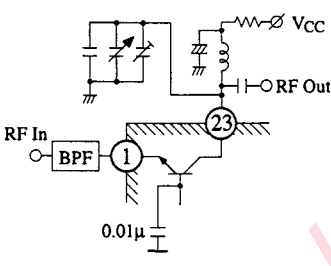
■ Pin Descriptions

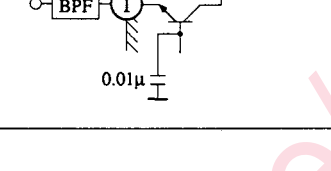
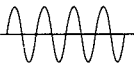
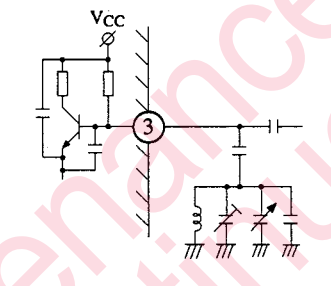
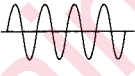
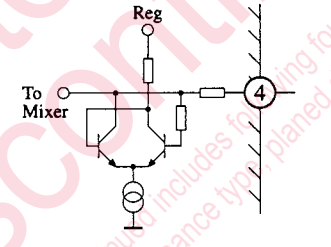
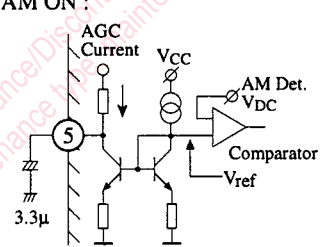
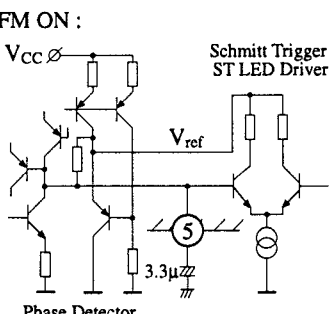
Pin No.	Pin Name	Waveform/ DC Bias (V)	Equivalent Circuit	Description
1	FM RF In	 RF Signal 0.6V		This pin provide the RF signal after a BandPass filter. Common Base Amplifier used is to reduce high frequency signal feedback through CB parasitive capacitor.
23	FM RF	 RF Signal 3.0V		With connection to the PVC externally, it is possible to tune the resonant point RF amplifier so as there is a constant tracking of 10.7MHz with the Oscillator.
2	FM FE GND	0V		
3	FM Osc	 3.0V f_{osc} AC = 0.6Vpp		A Colpitts Oscillator is used here. The Oscillator tank which is a PVC used in conjunction with the RF Amplifier tank has a common tuning knob which shifts both frequency at the same time. Here we can have $F_{osc} = F_{rf} + 10.7\text{MHz}$ or $F_{osc} = F_{rf} - 10.7\text{MHz}$ depends on the parallel capacitor and inductor coil used with the PVC.
4	AM Osc	 2.3V f_{osc} AC = 0.3Vpp		AM Osc pin. Positive Feedback Oscillator forms by differential pairs. Oscillation level decided by the saturation current. Oscillation $\approx 105\text{mVrms}$.
5	AGC / Pilot Det.	AM 1.2V FM 1.2V	AM ON :  FM ON : 	During AM On, when the signal level is low, AGC will not operate. When signal is high such that $V_{DC} + v_{AM} < V_{ref}$ then AGC will start to operate. The AGC is connected to AM IF Amp. & AM RF Amp. It is used to reduce the gains of both stages so as not to clip the AM signal when the input signal is strong. During FM stereo mode, the $3.3\mu\text{F}$ capacitor form a LPF with 10k resistor to filter off the AC of the pilot detector output. The DC output is then used to drive the ST LED.

Pin Descriptions (Continue)

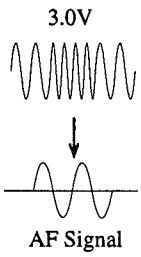
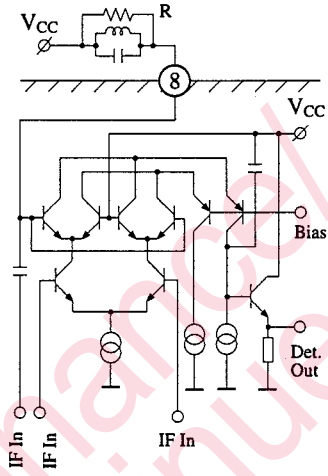
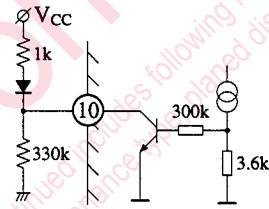
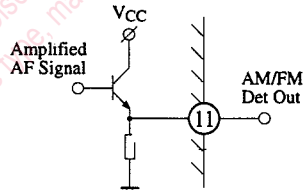
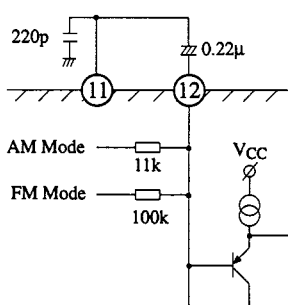
Pin No.	Pin Name	Waveform/ DC Bias (V)	Equivalent Circuit	Description
6	GND	0V		GND for the rest of the circuit except FM FE.
7	Vcc	3.0V		Vcc for the rest of the circuit except FM FE.
8	FM Quad. Det.	3.0V  AF Signal		Making use of Double Balance Modulator for this Quadrature Detector. Input signal of IF is converted to AF, and is amplified by the complimentary common base Amp. to improve the dynamic range. An emitter follower to provide a low output impedance. The external IFT used is to adjust a 90° phase shift at 10.7MHz. R can be changed to adjust Det. Out level.
9	NC			
10	ST IND	LED On = 0.2V LED Off = 2.2V		Stereo LED driver and VCO monitor pin. Current capability is 30mA maximum. Usable LED current is 4mA. During FM ST mode, the 38kHz free-run frequency can be measured from this pin.
11	Det Out	FM = 0.5V AM = 0.2V		AM & FM Detector Output pin. Both AM and FM employed an Emitter Follower at their output stage to obtain a low output impedance (≈150Ω). They both share a 5kΩ at the emitter and output pin.
12	MPX In	FM = 0.6V AM = 0.8V		MPX input pin. Input impedance is 11kΩ in AM mode and 100kΩ in FM mode, 0.22μF is used as input coupling capacitor, and low-cut filter. Cut-off frequency is 66Hz for AM & 7Hz for FM.

■ Pin Descriptions (Continue)

Pin No.	Pin Name	Waveform/ DC Bias (V)	Equivalent Circuit	Description
13 14	R-ch Out L-ch Out	FM 1.0V AM 1.5V		<p>MPX output pins. Output circuit configuration is a current mirror. Output impedance is 5kΩ. Time constant for de-emphasis is 75µs, determined by external capacitor 0.015µF.</p> $f_L = 1/(2\pi RC)$ $= 1/(2\pi \times 11k \times 0.22\mu)$ $= 66\text{Hz}$
15	Phase Det / Switch	AM 3.0V FM ST : 1.15V FM Mono : 0V		<p>During FM ST mode, the external components are used as LPF to filter off the AC of the phase detector output. The output is fed to the DC Amp to control the VCO frequency.</p> <p>When the switch is in the FM Mono position, QV18 is turned on. The VCO will not function. The L ch. and R ch. outputs will be forced to become Monoaural.</p> <p>During both FM ST and FM Mono modes, QV8 will be off. Current will be supplied to FM FE, FM IF and MPX blocks of the chip. Current supply to the AM part of the chip will be cut off to save power.</p> <p>In AM mode, current supply to the FM and MPX parts of the chip will be cut off.</p>
16	VCO	AM : - FM ST : 0.4V FM Mono : 0.2V		<p>Oscillation frequency measured at this pin is 76kHz, determined by external resistors and capacitor. Adjust VR until the frequency at pin 16 is 38kHz + 100Hz. The 470pF is a styrole/polypropylene film capacitor for guarantee of temperature characteristics and limits.</p>
17	Regulator	3.0V		VCC pin for first stage of FM IF Amp., AM Mixer and AM Osc.
18	AM IF In	2.9V		<p>AM IF input pin. 3 stages of differential amplifiers make up of this AM IF Amp., with one stage shared between AM & FM.</p> <p>First stage differential amplifier, making use of the load for FM first stage differential amplifier. The emitter current of this differential amplifier is controllable through AGC. In which, gain can be controlled.</p>

■ Pin Descriptions (Continue)

Pin No.	Pin Name	Waveform/ DC Bias (V)	Equivalent Circuit	Description
19	FM IF In	2.9V		<p>FM IF input pin. Input impedance is decided by the resistor connected from Input transistor Base to Reg., and the transistor Base impedance. This FM IF Amp. is made up of 5 stages of differential Amplifiers.</p>
20	AM Mix	3.0V		<p>AM Mixer output pin. A Balance Modulator is employed. Conversion gain is about 10dB.</p>
21	FM Mixer Out	3.0V f = 10.7MHz		<p>This Pin provides a 10.7MHz output obtained from the Mixer after the Limiter. An Intermediate Transformer is employed before passing to IF IC to obtain peak IF Out and to filter unwanted harmonics thru' LPF formed by 22Ω and 0.01μF to GND. The internal Limiter helps to limit the IF amplitude so as not to saturate the Mixer's transistors. A Mixer of Double Balanced Modulator nature helps to improve IM Range.</p>
22	FM Vcc	3.0V		Vcc for FM FE Block only
24	AM RF In	3.0V RF Signal		<p>2 pairs of Differential Amplifier made up the AM RF Amplifier. AM RF signal through the BASE of the Diff. Amp. Normal operation involve only the internal Diff. pair. When AGC is on during high signal input, external Diff. Amp. and the active load turns on which lower down the RF Amp. gain.</p>

■ Application Notes

1 Stereo Indicator (Pin 10)

This pin is used as stereo indicator and VCO check pin.

a) In stereo mode, connect as shown below.



b) When not in use, leave pin 10 open.

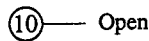

c) During checking of 38kHz (1/2 VCO free-run frequency), the connection is as shown below.



The adjustment of 38kHz is done by pin 16. By adjusting 10kΩ variable resistor, 38kHz can be tuned.

2 AM IF Input (Pin 18)

This is the input pin for AM IF limiter, the connection is as shown below.

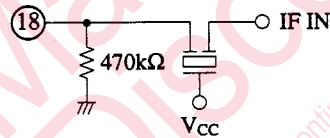

The resistor of 470kΩ is used to prevent DC offset of the input differential amp. of AM IF Limiter.

3 FM Muting

This IC has a built-in Muting Circuit for FM Interchannel Noise. (The mute is such that the weak station signal can still be detected but not noise in between channels.)

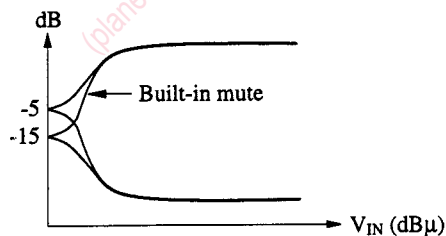

■ Application Notes (Continue)**4 VCC Pattern****a) FM Front-end VCC (Pin 22)**

Pin 22 is only used for FM Front-end, both internally and externally. The 22Ω resistor on pin 21 and a 0.01μF capacitor from pin 22 to GND is for AC filtering from FM Mixer.

b) REG Pin (Pin 17)

Internally, this pin is used for FM IF limiter, input differential amp. biasing plus AM Mixer and Osc biasing. In PCB design, it is advisable to connect AM ceramic filter to this pin and also the AM Osc coil to this pin directly. Externally, this REG Pin share the same path as VCC.

c) IC VCC (Pin 6)

This is the common VCC pin for the IC.

5 GND Pattern**a) FM Front-end GND (Pin 2)**

This pin is used for only FM FE internally. Externally, it is the same path as the IC GND. (pin 7)

b) IC GND (Pin 7)

This pin is the common GND pin.

Maintenance/Discontinued
(planned maintenance type, maintenance type, planned discontinued type, discontinued type)
Maintenance/Discontinued includes following four Product lifecycle stage.

Request for your special attention and precautions in using the technical information and semiconductors described in this book

- (1) If any of the products or technical information described in this book is to be exported or provided to non-residents, the laws and regulations of the exporting country, especially, those with regard to security export control, must be observed.
- (2) The technical information described in this book is intended only to show the main characteristics and application circuit examples of the products. No license is granted in and to any intellectual property right or other right owned by Panasonic Corporation or any other company. Therefore, no responsibility is assumed by our company as to the infringement upon any such right owned by any other company which may arise as a result of the use of technical information described in this book.
- (3) The products described in this book are intended to be used for standard applications or general electronic equipment (such as office equipment, communications equipment, measuring instruments and household appliances).
Consult our sales staff in advance for information on the following applications:
 - Special applications (such as for airplanes, aerospace, automobiles, traffic control equipment, combustion equipment, life support systems and safety devices) in which exceptional quality and reliability are required, or if the failure or malfunction of the products may directly jeopardize life or harm the human body.
 - Any applications other than the standard applications intended.
- (4) The products and product specifications described in this book are subject to change without notice for modification and/or improvement. At the final stage of your design, purchasing, or use of the products, therefore, ask for the most up-to-date Product Standards in advance to make sure that the latest specifications satisfy your requirements.
- (5) When designing your equipment, comply with the range of absolute maximum rating and the guaranteed operating conditions (operating power supply voltage and operating environment etc.). Especially, please be careful not to exceed the range of absolute maximum rating on the transient state, such as power-on, power-off and mode-switching. Otherwise, we will not be liable for any defect which may arise later in your equipment.
 - Even when the products are used within the guaranteed values, take into the consideration of incidence of break down and failure mode, possible to occur to semiconductor products. Measures on the systems such as redundant design, arresting the spread of fire or preventing glitch are recommended in order to prevent physical injury, fire, social damages, for example, by using the products.
- (6) Comply with the instructions for use in order to prevent breakdown and characteristics change due to external factors (ESD, EOS, thermal stress and mechanical stress) at the time of handling, mounting or at customer's process. When using products for which damp-proof packing is required, satisfy the conditions, such as shelf life and the elapsed time since first opening the packages.
- (7) This book may be not reprinted or reproduced whether wholly or partially, without the prior written permission of our company.