

QUAD OPERATIONAL AMPLIFIERS

The KA248/KA348 is a true quad KA741. It consists of four independent, high-gain, internally compensated, low-power operational amplifiers which have been designed to provide functional characteristics identical to those of the familiar KA741 operational amplifier. In addition the total supply current for all four amplifiers is comparable to the Supply current of a single KA741 type OP Amp.

Other features include input offset currents and input bias current which are much less than those of a standard KA741. Also, excellent isolation between amplifiers has been achieved by independently biasing each amplifier and using layout techniques which minimize thermal coupling.

FEATURES

- KA741 OP Amp operating characteristics
- Low supply current drain
- Class AB output stage-no crossover distortion
- Pin compatible with the KA324 & KA3403
- Low input offset voltage- 1mV Type.
- Low input offset current-4nA Type.
- Low input bias current-30nA Type.
- Gain bandwidth product for KA348 (unity gain)-1.0MHz Type.
- High degree of isolation between amplifiers-120dB
- Overload protection for inputs and outputs

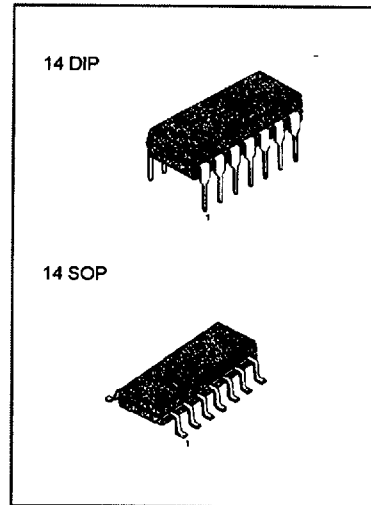

BLOCK DIAGRAM

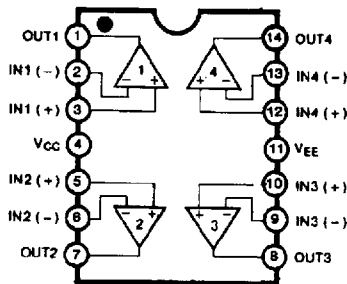

ORDERING INFORMATION

Device	Package	Operating Temperature
KA348	14 DIP	0 ~ +70°C
KA348D	14 SOP	
KA248	14 DIP	-25 ~ +85°C
KA248D	14 SOP	

SCHEMATIC DIAGRAM (One Section Only)

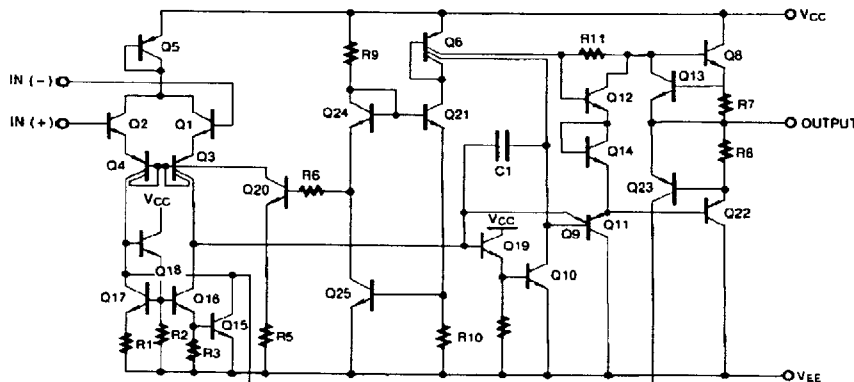

ABSOLUTE MAXIMUM RATINGS (T_A = 25°C)

Characteristic	Symbol	Value	Unit
Supply Voltage	V _{CC}	± 18	V
Differential Input Voltage	V _{I(DIFF)}	± 36	V
Input Voltage	V _I	± 18	V
Output Short Circuit Duration		Continuous	
Operating Temperature KA248	T _{OPR}	- 25 ~ +85	°C
KA348		0 ~ +70	°C
Storage Temperature	T _{STG}	- 65 ~ +150	°C

ELECTRICAL CHARACTERISTICS

(V_{CC} = 15V, V_{EE} = -15V, T_A = 25°C, unless otherwise specified)

Characteristic	Symbol	Test Conditions	KA248			KA348			Unit
			Min	Typ	Max	Min	Typ	Max	
Input Offset Voltage	V _{IO}	R _S ≤ 10KΩ		1	6.0		1	6.0	mV
			NOTE 1					7.5	
Input Offset Current	I _{IO}			4	50		4	50	nA
			NOTE 1					100	
Input Bias Current	I _{BIAS}			30	200		30	200	nA
			NOTE 1					400	
Input Resistance	R _I		0.8	2.5		0.8	2.5	MΩ	
Supply Current (all Amplifiers)	I _{CC}			2.4	4.5		2.4	4.5	mA
Large Signal Voltage Gain	G _V	R _L ≥ 2KΩ		25	160		25	160	V/mV
			NOTE 1		15			15	
Channel Separation	CS	f = 1KHz to 20KHz		120			120	dB	
Common Mode Input Voltage Range	V _{I(R)}	NOTE 1		± 12			± 12	V	
Small Signal Bandwidth	BW	G _V = 1		1.0			1.0	MHz	
Phase Margin	MPH	G _V = 1		60			60	Degress	
Slew Rate	SR	G _V = 1		0.5			0.5	V/μs	
Output Short Circuit Current	I _{SC}			25			25	mA	
Output Voltage Swing	V _{O(P-P)}	R _L ≥ 10KΩ	NOTE 1	± 12	± 13		± 12	± 13	V
		R _L ≥ 2KΩ		± 10	± 12		+ 0	± 12	
Common Mode Rejection Ratio	CMRR	R _S ≥ 10KΩ	NOTE 1	70	90		70	90	dB
Power Supply Rejection Ratio	PSRR	R _S ≥ 10KΩ	NOTE 1	77	96		77	96	dB

KA348: 0 ≥ T_A ≥ +70°C

KA248: -25 ≥ T_A ≥ +85°C

TYPICAL PERFORMANCE CHARACTERISTICS

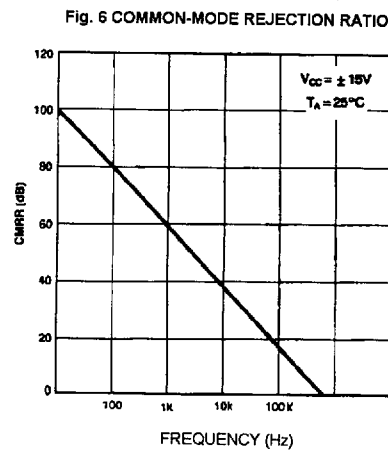
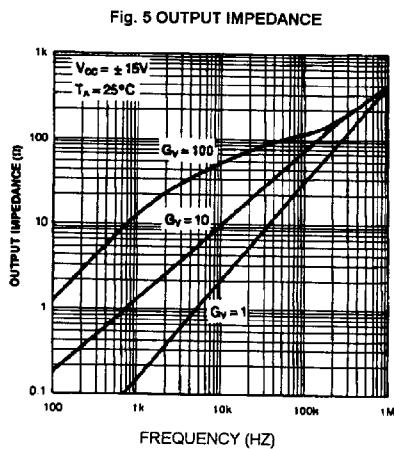
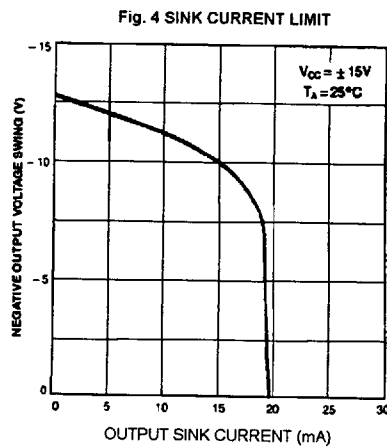
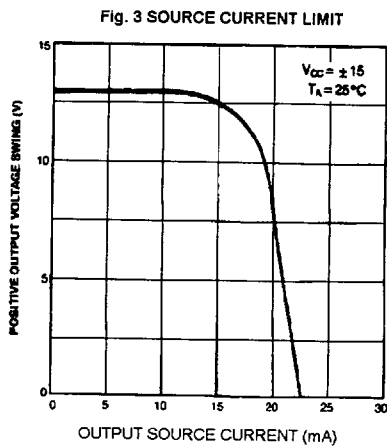
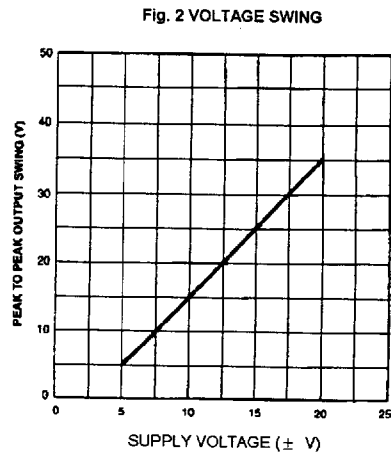
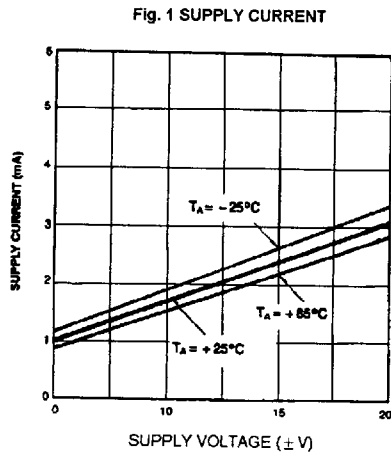

Fig. 7 OPEN LOOP FREQUENCY RESPONSE

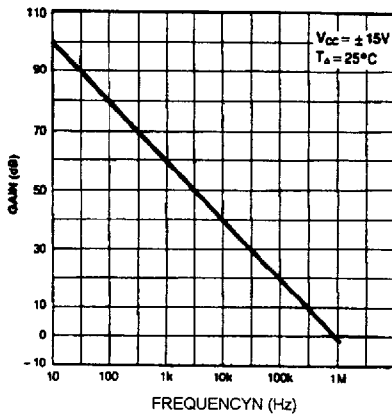

Fig. 8 BODE PLOT



Fig. 9 LARGE SIGNAL PULSE RESPONSE

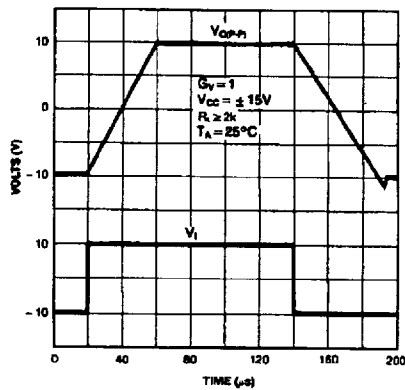

Fig. 10 SMALL SIGNAL PULSE RESPONSE

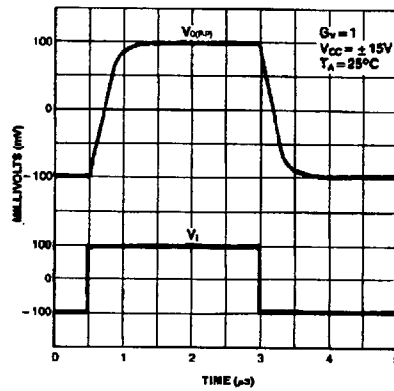

Fig. 11 UNDISTORTED OUTPUT VOLTAGE SWING

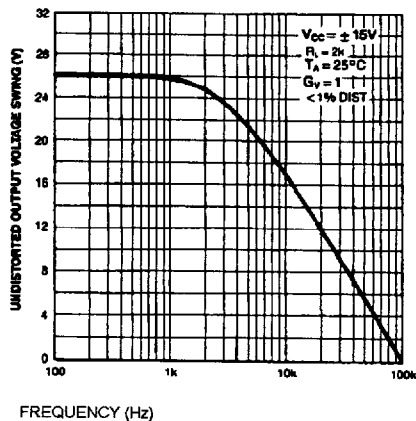

Fig. 12 INVERTING LARGE SIGNAL PULSE RESPONSE

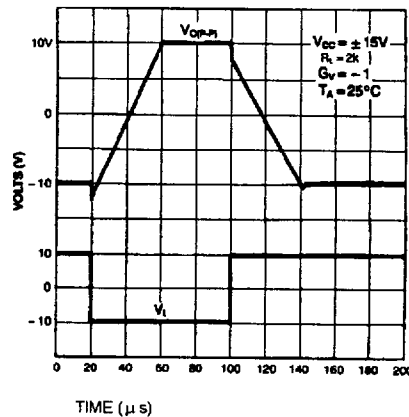

Fig. 13 INPUT NOISE VOLTAGE AND NOISE CURRENT

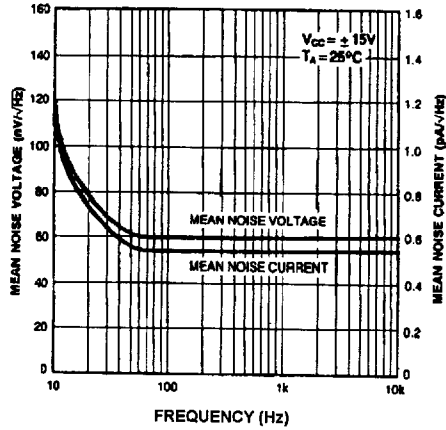

Fig. 14 POSITIVE COMMON-MODE INPUT VOLTAGE LIMIT

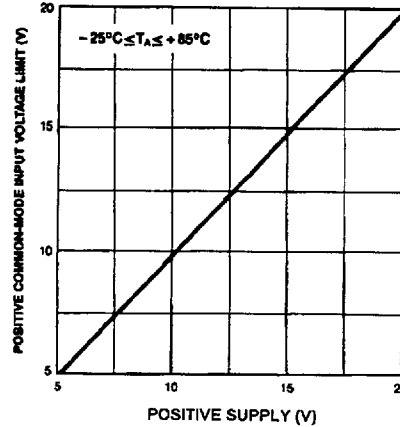
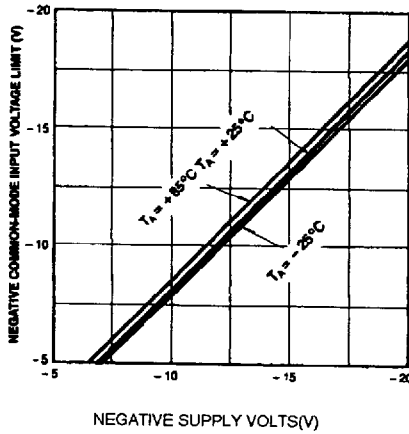
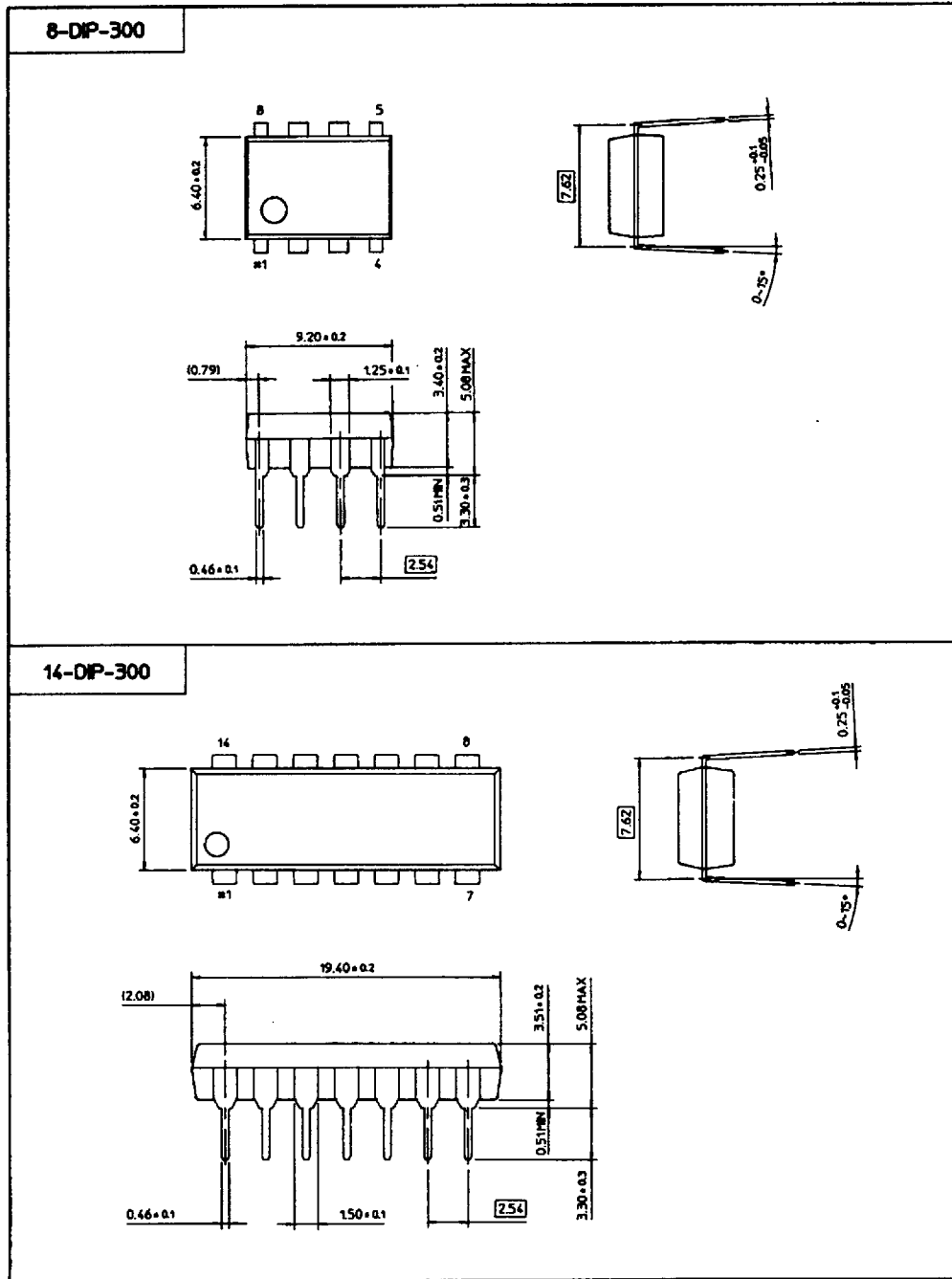

Fig. 15 NEGATIVE COMMON-MODE INPUT VOLTAGE LIMIT



Dimensions in Millimeters



8-SOP-225

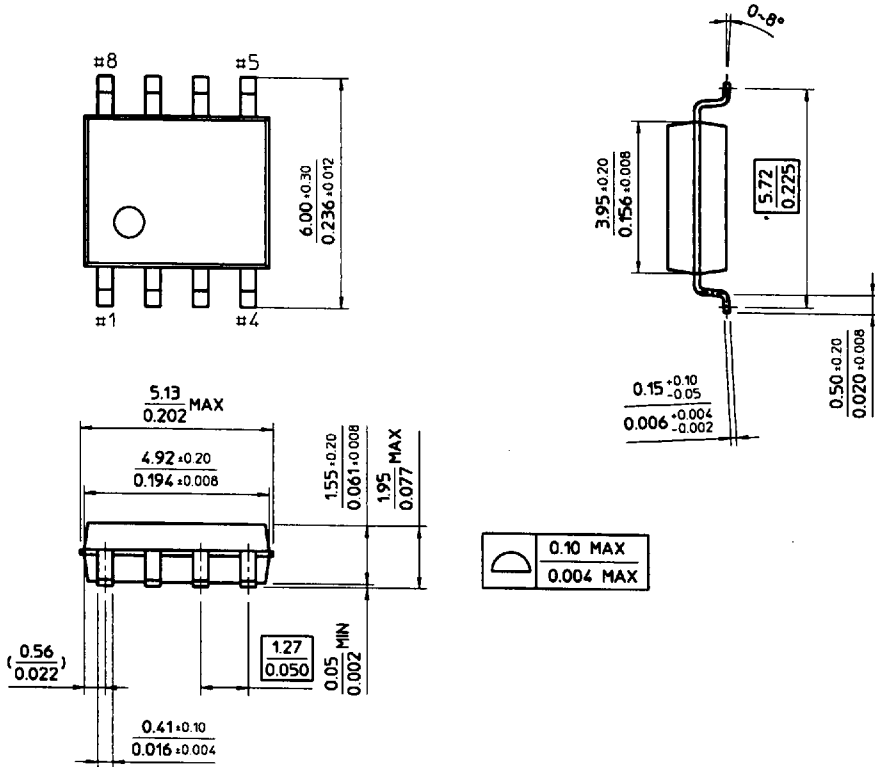

14-SOP-225B

