



# 3.3V CMOS TRIPLE 3-INPUT AND GATE WITH 5 VOLT TOLERANT I/O

**IDT74LVC11A**

## FEATURES:

- 0.5 MICRON CMOS Technology
- ESD > 2000V per MIL-STD-883, Method 3015; > 200V using machine model (C = 200pF, R = 0)
- Vcc = 3.3V ± 0.3V, Normal Range
- Vcc = 2.7V to 3.6V, Extended Range
- CMOS power levels (0.4µ W typ. static)
- Rail-to-Rail output swing for increased noise margin
- All inputs, outputs, and I/Os are 5V tolerant
- Supports hot insertion
- Available in SOIC, SSOP, and TSSOP packages

## DRIVE FEATURES:

- High Output Drivers: ±24mA
- Reduced system switching noise

## DESCRIPTION:

The LVC11A triple 3-input AND gate is built using advanced dual metal CMOS technology. The LVC11A device provides the 3-input AND function.

Inputs can be driven from either 3.3V or 5V devices. This feature allows the use of this device as a translator in a mixed 3.3V/5V system environment.

The LVC11A has been designed with a ±24mA output driver. This driver is capable of driving a moderate to heavy load while maintaining speed performance.

## APPLICATIONS:

- 3.3V high speed systems
- 3.3V and lower voltage computing systems

## FUNCTIONAL BLOCK DIAGRAM

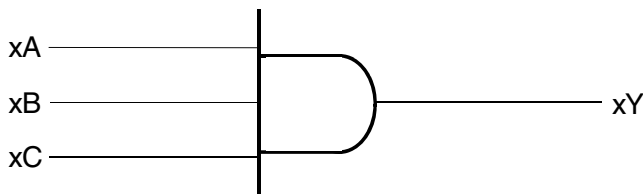

## FUNCTION TABLE<sup>(1)</sup>

| Inputs |    |    | Outputs |
|--------|----|----|---------|
| xA     | xB | xC | xY      |
| L      | L  | L  | L       |
| L      | L  | H  | L       |
| L      | H  | L  | L       |
| L      | H  | H  | L       |
| H      | L  | L  | L       |
| H      | L  | H  | L       |
| H      | H  | L  | L       |
| H      | H  | H  | H       |

### NOTE:

1. H = HIGH Voltage Level  
L = LOW Voltage Level

## PIN CONFIGURATION

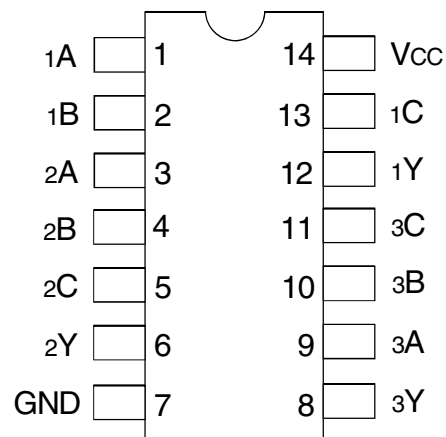

SOIC/ SSOP/ TSSOP  
TOP VIEW

## PIN DESCRIPTION

| Pin Number | Symbol  | Name and Function       |
|------------|---------|-------------------------|
| 1, 3, 9    | 1A - 3A | Data Inputs             |
| 2, 4, 10   | 1B - 3B | Data Inputs             |
| 7          | GND     | Ground (0V)             |
| 12, 6, 8   | 1Y - 3Y | Data Outputs            |
| 13, 5, 11  | 1C - 3C | Data Inputs             |
| 14         | Vcc     | Positive Supply Voltage |

The IDT logo is a registered trademark of Integrated Device Technology, Inc.

INDUSTRIAL TEMPERATURE RANGE

MARCH 1999

**ABSOLUTE MAXIMUM RATINGS<sup>(1)</sup>**

| Symbol                             | Description   | Max          | Unit |
|------------------------------------|---|--------------|------|
| VTERM                              | Terminal Voltage with Respect to GND                                  | -0.5 to +6.5 | V    |
| TSTG                               | Storage Temperature   | -65 to +150  | °C   |
| IOUT                               | DC Output Current   | -50 to +50   | mA   |
| I <sub>IK</sub><br>I <sub>OK</sub> | Continuous Clamp Current,<br>V <sub>I</sub> < 0 or V <sub>O</sub> < 0 | -50          | mA   |
| I <sub>CC</sub><br>I <sub>SS</sub> | Continuous Current through each<br>V <sub>CC</sub> or GND             | ±100         | mA   |

**NOTE:**

1. Stresses greater than those listed under ABSOLUTE MAXIMUM RATINGS may cause permanent damage to the device. This is a stress rating only and functional operation of the device at these or any other conditions above those indicated in the operational sections of this specification is not implied. Exposure to absolute maximum rating conditions for extended periods may affect reliability.

**CAPACITANCE** (T<sub>A</sub> = +25°C, F = 1.0MHz)

| Symbol           | Parameter <sup>(1)</sup> | Conditions            | Typ. | Max. | Unit |
|------------------|--------------------------|-----------------------|------|------|------|
| C <sub>IN</sub>  | Input Capacitance        | V <sub>IN</sub> = 0V  | 4.5  | 6    | pF   |
| C <sub>OUT</sub> | Output Capacitance       | V <sub>OUT</sub> = 0V | 5.5  | 8    | pF   |
| C <sub>I/O</sub> | I/O Port Capacitance     | V <sub>IN</sub> = 0V  | 6.5  | 8    | pF   |

**NOTE:**

1. As applicable to the device type.

**DC ELECTRICAL CHARACTERISTICS OVER OPERATING RANGE**

Following Conditions Apply Unless Otherwise Specified:

Operating Condition: T<sub>A</sub> = -40°C to +85°C

| Symbol   | Parameter  | Test Conditions   |                            | Min. | Typ. <sup>(1)</sup> | Max. | Unit |
|--|--|---|----------------------------|------|---------------------|------|------|
| V <sub>IH</sub>  | Input HIGH Voltage Level                               | V <sub>CC</sub> = 2.3V to 2.7V  |                            | 1.7  | —                   | —    | V    |
|  |  | V <sub>CC</sub> = 2.7V to 3.6V  |                            | 2    | —                   | —    |      |
| V <sub>IL</sub>  | Input LOW Voltage Level                                | V <sub>CC</sub> = 2.3V to 2.7V  |                            | —    | —                   | 0.7  | V    |
|  |  | V <sub>CC</sub> = 2.7V to 3.6V  |                            | —    | —                   | 0.8  |      |
| I <sub>IH</sub><br>I <sub>IL</sub>                       | Input Leakage Current                                  | V <sub>CC</sub> = 3.6V  | V <sub>I</sub> = 0 to 5.5V | —    | —                   | ±5   | μA   |
| I <sub>OZH</sub><br>I <sub>OZL</sub>                     | High Impedance Output Current<br>(3-State Output pins) | V <sub>CC</sub> = 3.6V  | V <sub>O</sub> = 0 to 5.5V | —    | —                   | ±10  | μA   |
| I <sub>OFF</sub>   | Input/Output Power Off Leakage                         | V <sub>CC</sub> = 0V, V <sub>IN</sub> or V <sub>O</sub> ≤ 5.5V              |                            | —    | —                   | ±50  | μA   |
| V <sub>IK</sub>  | Clamp Diode Voltage                                    | V <sub>CC</sub> = 2.3V, I <sub>IN</sub> = -18mA                             |                            | —    | -0.7                | -1.2 | V    |
| V <sub>H</sub>   | Input Hysteresis                                       | V <sub>CC</sub> = 3.3V  |                            | —    | 100                 | —    | mV   |
| I <sub>CC1</sub><br>I <sub>CC2</sub><br>I <sub>CC3</sub> | Quiescent Power Supply Current                         | V <sub>CC</sub> = 3.6V, V <sub>IN</sub> = GND or V <sub>CC</sub>            |                            | —    | —                   | 10   | μA   |
| ΔI <sub>CC</sub>   | Quiescent Power Supply Current Variation               | One input at V <sub>CC</sub> - 0.6V, other inputs at V <sub>CC</sub> or GND |                            | —    | —                   | 500  | μA   |

**NOTE:**

1. Typical values are at V<sub>CC</sub> = 3.3V, +25°C ambient.

## OUTPUT DRIVE CHARACTERISTICS

| Symbol | Parameter           | Test Conditions <sup>(1)</sup> |               | Min.      | Max. | Unit |
|--------|---------------------|--------------------------------|---------------|-----------|------|------|
| VOH    | Output HIGH Voltage | VCC = 2.3V to 3.6V             | IOH = - 0.1mA | VCC - 0.2 | —    | V    |
|        |                     | VCC = 2.3V                     | IOH = - 6mA   | 2         | —    |      |
|        |                     | VCC = 2.3V                     | IOH = - 12mA  | 1.7       | —    |      |
|        |                     | VCC = 2.7V                     |               | 2.2       | —    |      |
|        |                     | VCC = 3V                       |               | 2.4       | —    |      |
|        |                     | VCC = 3V                       | IOH = - 24mA  | 2.2       | —    |      |
| VOL    | Output LOW Voltage  | VCC = 2.3V to 3.6V             | IOL = 0.1mA   | —         | 0.2  | V    |
|        |                     | VCC = 2.3V                     | IOL = 6mA     | —         | 0.4  |      |
|        |                     |                                | IOL = 12mA    | —         | 0.7  |      |
|        |                     | VCC = 2.7V                     | IOL = 12mA    | —         | 0.4  |      |
|        |                     | VCC = 3V                       | IOL = 24mA    | —         | 0.55 |      |

**NOTE:**  
1. VIH and VIL must be within the min. or max. range shown in the DC ELECTRICAL CHARACTERISTICS OVER OPERATING RANGE table for the appropriate VCC range. TA = - 40°C to + 85°C.

## OPERATING CHARACTERISTICS, TA = 25°C

| Symbol | Parameter                              | Test Conditions     | VCC = 2.5V ± 0.2V | VCC = 3.3V ± 0.3V | Unit |
|--------|--|---------------------|-------------------|-------------------|------|
|        |  |                     | Typical           | Typical           |      |
| CPD    | Power Dissipation Capacitance per Gate | CL = 0pF, f = 10Mhz | —                 | —                 | pF   |

## SWITCHING CHARACTERISTICS<sup>(1)</sup>

| Symbol | Parameter                             | VCC = 2.7V |      | VCC = 3.3V ± 0.3V |      | Unit |
|--------|---------------------------------------|------------|------|-------------------|------|------|
|        |                                       | Min.       | Max. | Min.              | Max. |      |
| tPLH   | Propagation Delay<br>xA, xB, xC to xY | —          | 7    | —                 | 6.2  | ns   |
| tPHL   |                                       |            |      |                   |      |      |
| tSK(0) | Output Skew <sup>(2)</sup>            | —          | —    | —                 | 500  | ps   |

**NOTES:**  
1. See TEST CIRCUITS AND WAVEFORMS. TA = - 40°C to + 85°C.  
2. Skew between any two outputs of the same package and switching in the same direction.

TEST CIRCUITS AND WAVEFORMS  
TEST CONDITIONS

| Symbol            | V <sub>CC</sub> <sup>(1)</sup> = 2.5V ± 0.2V | V <sub>CC</sub> <sup>(2)</sup> = 3.3V ± 0.3V & 2.7V | Unit |
|-------------------|--|---|------|
| V <sub>LOAD</sub> | 2 x V <sub>CC</sub>                          | 6   | V    |
| V <sub>IH</sub>   | V <sub>CC</sub>                              | 2.7   | V    |
| V <sub>T</sub>    | V <sub>CC</sub> / 2                          | 1.5   | V    |
| V <sub>LZ</sub>   | 150  | 300   | mV   |
| V <sub>HZ</sub>   | 150  | 300   | mV   |
| C <sub>L</sub>    | 30   | 50  | pF   |

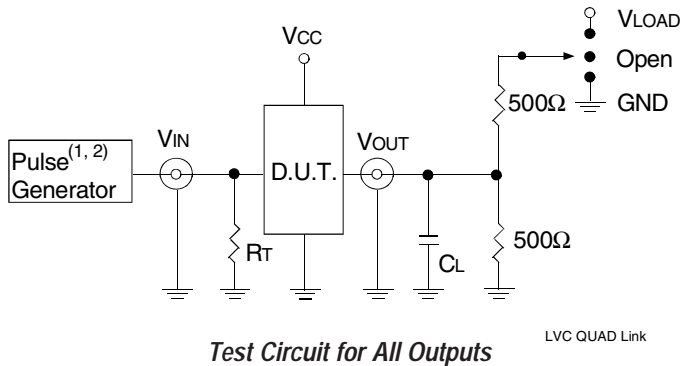

DEFINITIONS:

C<sub>L</sub> = Load capacitance: includes jig and probe capacitance.  
R<sub>T</sub> = Termination resistance: should be equal to Z<sub>OUT</sub> of the Pulse Generator.

NOTES:

1. Pulse Generator for All Pulses: Rate ≤ 10MHz; t<sub>r</sub> ≤ 2ns; t<sub>r</sub> ≤ 2ns.
2. Pulse Generator for All Pulses: Rate ≤ 10MHz; t<sub>r</sub> ≤ 2.5ns; t<sub>r</sub> ≤ 2.5ns.

SWITCH POSITION

| Test                                    | Switch            |
|---|-------------------|
| Open Drain<br>Disable Low<br>Enable Low | V <sub>LOAD</sub> |
| Disable High<br>Enable High             | GND               |
| All Other Tests                         | Open              |

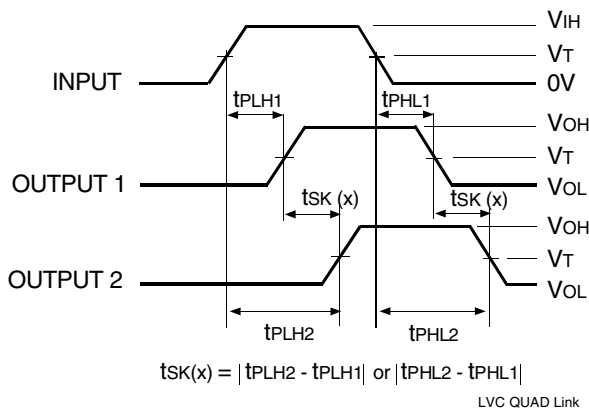

NOTES:

1. For tsk(o) OUTPUT1 and OUTPUT2 are any two outputs.
2. For tsk(b) OUTPUT1 and OUTPUT2 are in the same bank.

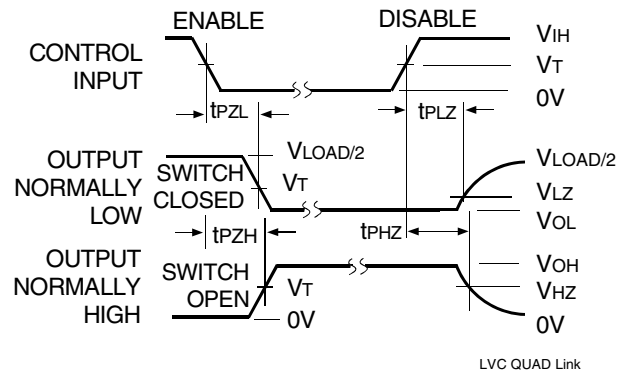
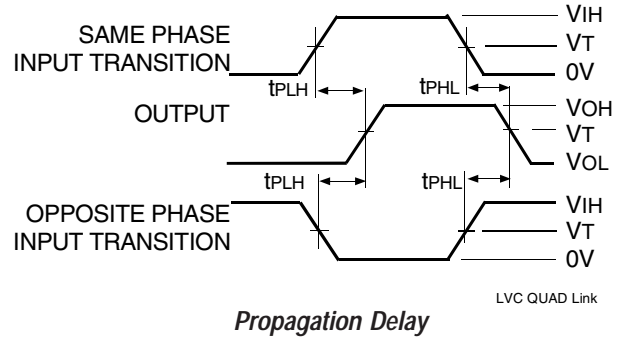

NOTE:

1. Diagram shown for input Control Enable-LOW and input Control Disable-HIGH.

Enable and Disable Times

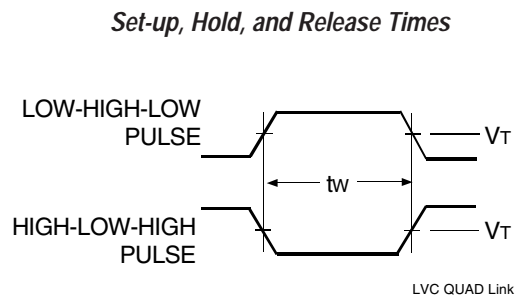
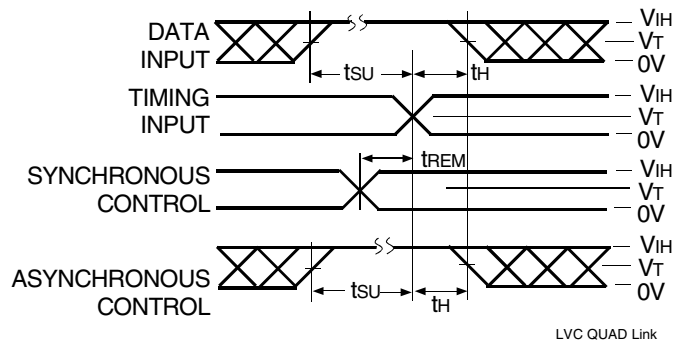

## ORDERING INFORMATION

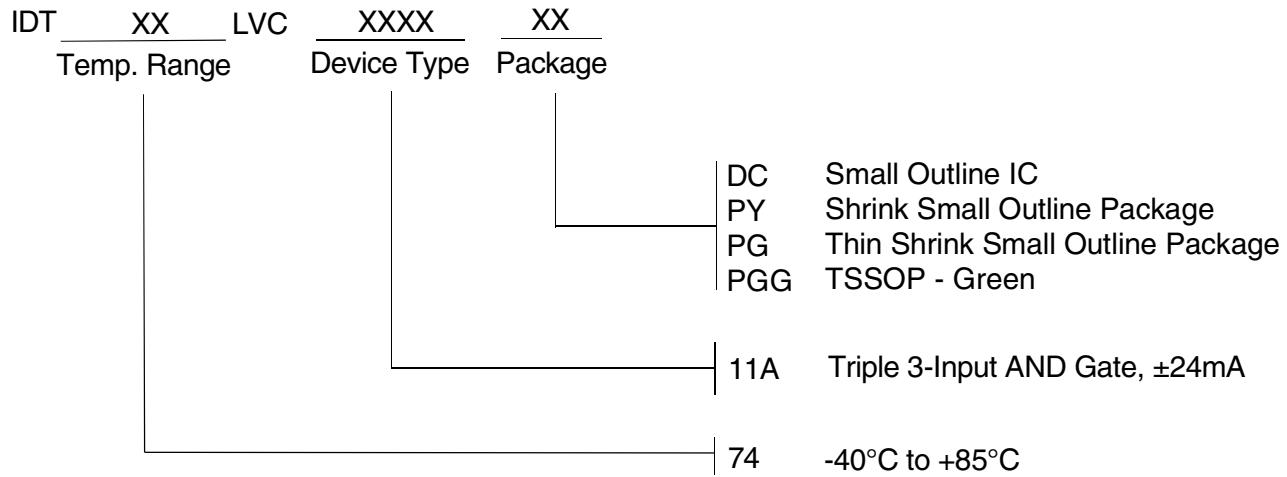

**CORPORATE HEADQUARTERS**  
6024 Silver Creek Valley Road  
San Jose, CA 95138

**for SALES:**  
800-345-7015 or 408-284-8200  
fax: 408-284-2775  
www.idt.com

**for Tech Support:**  
logichelp@idt.com